

## CATALOG INDEX

### A

Air Valve	C-6
Air Vent	E-10
Amp Meter	B-32
AO Smith Tanks	C-2 & C3

### B

Ball Valves	
Brass	E-6
Ductile Iron	E-6
Pex	D-14
PVC	E-6
Belled End PVC Pipe	D-2 thru D-4
Black Nipples	D-22 thru D-28
Black Steel Fittings	D-16 thru D-21
Bleeder Orifice	C-6
Brass Fittings	D-36
Bury Hydrant	E-9
Butt Connectors	B-30
Butterfly Valve	E-6

### C

Cable	B-30
Cable Sizing Chart	
Cast Iron Flanges	D-29
Cement - PVC	D-10
Centralizers	F-3
Cetco Drilling Fluids	F-9 thru F-10
Check Valves	
Flomatic	E-1 thru E-4
Simmons	E-5
Clamps - SS	B-7 & D-9
Cleaner - PVC	D-11
Clearview Coupling	E-10
Control Box Repair Parts	B-9
Control Boxes	B-8
Control Panels	B-11
Control Panel Parts	B-12
Crimping Pliers - Cable	B-32
Crimping Tool - Pex	D-14
Cycle Gard Valves	E-8

### D

D&K Clearview Couplings	E-10
D&K Sight Checks	E-10
Definite Purpose Contactor	B-9
Disconnects	B-12
Dole Valves	E-7
Dope Brush	D-37
Drilling Products - Cetco	F-9 thru F-10

### E

Electrical Tape	B-31
-----------------	------

### F

Filter Cartridges	F-7
Filter Housings	F-7
Filter Sand	
Flanges - Cast Iron	D-29
Flange Gaskets	D-29
Float Switch - SJE Rhombus	C-8
Float Switch - Square D	C-8
Flow Control Valves	E-7
Flow Meters	F-1
Fuse Reducers	B-14
Fuses - 125V	B-13
Fuses - 250V	B-13
Fuses - 600V	B-14

### G

Galvanized Nipples	D-22 thru D-28
Galvanized Steel Fittings	D-16 thru D-21
Gate Valves - Brass	E-6
Gauges	C-6
Glue - PVC	D-10
Grooved Fittings	D-30
Ground Rods & Clamps	B-31

### H

Hammer Unions	D-12
Hand Cleaning Towels	D-11
Heat Shrink Kits	B-30
Hose Bibbs	C-6
Hose Clamps	B-7 & D-9
Hydrants	E-9

### I

### J

### K

Kwik Zip Centralizers	F-3
-----------------------	-----

### L

Liquid Tight Conduit	B-31
Littlefuse Relays	B-9

### M

Meters	
Ohm Meter	B-32
Amp Meter	B-32
Volt Meter	B-32
Flow Meter	F-1
Multi Meter	B-32
Motors	
Simflo 4" Motors	B-1
AY McDonald 4" Motors	B-2
6-10" Hitachi 6-10" Motors	B-3
SME 6-10" Motors	B-4
AY McDonald 6-10" Motors	B-5
Motor Saver	B-9
Multi Meter	B-32

## CATALOG INDEX

### N

### O

Ohmeter B-32  
Overload Relay B-12

### P

Panels - Control B-11  
Panel Parts B-12  
PEX Ball Valves D-14  
PEX Fittings D-14  
PEX Tools D-14  
PEX Tubing D-13  
Phase Technologies VFD's B-16 thru B-29  
Pipe  
    PVC D-1 thru D-4  
    Steel D-15  
Pipe Dope D-37  
Pipe Gasket Lube D-11  
Pitless Adapters F-2  
Poly Pipe D-12  
Poly Storage Tanks C-4  
Poly Transitions D-12  
Polymate Adapters D-12  
Pressure Gauges C-6  
Pressure Relief Valves C-6  
Pressure Switches B-10 & C-7  
Pressure Tanks C-1 thru C-2  
Primer - PVC D-11  
Pumps  
    AY McDonald 4" Pumps A-5 thru A-10  
    Chemical Feed Pumps A-17  
    E.Sybox Booster Systems A-19  
    HiLo N Series 4" Pumps A-1 thru A-2  
    HiLo S Series 4" Pumps A-3 thru A-4  
    HiLo H Series 6-10" Pumps A-11 thru A-12  
    Jet Pumps A-21  
    Self Priming Booster Pumps A-18  
    Simflo Sub Turbine Pumps A-13 thru A-16  
Pump Saver B-9  
PVC Cements D-10  
PVC Cleaners D-11  
PVC Compression Couplings D-7  
PVC Fittings D-5 thru D-8  
PVC Insert Fittings D-7  
PVC Motor Shrouds B-6  
PVC Pipe D-1 thru D-4  
PVC Primers D-11  
PVC Repair Couplings D-7  
PVC Slotted Well Casing D-37  
PVC Well Casing D-2

### Q

### R

### S

Sand  
Sand Separators - Lakos F-8  
Sch 120 Pipe D-1  
Sch 40 Pipe D-2, D-3 & D-4  
Sch 40 PVC Fittings D-5 thru D-7  
Sch 80 Pipe D-1  
Sch 80 PVC Fittings D-8  
Schrader Valves C-6  
Sediment Filters F-7  
Siemens Control Panels B-11  
Siemens Panel Parts B-12  
Sight Check E-10  
Simpson Ohmeter B-32  
Slotted Well Casing D-3  
Splice Kits B-30  
Spray Foam D-11  
Stainless Steel Clamps B-7 & D-9  
Stainless Steel Fittings D-31 thru D-36  
Standard Pressure Tanks C-3  
Steel Drop Pipe D-15  
Submersible Cable B-30  
Sump, Sewage & Effluent Pumps A-20  
Swing Check Valves  
    Brass E-6  
    Ductile Iron E-6  
Symcom Relays B-9

### T

Tank Tee Kits C-6  
Tank Tees C-6  
Tape B-31  
Thread Compounds D-37  
Threaded PVC Pipe D-1  
TiteLoc PVC Casing D-4  
Torque Arrestor F-3  
Transitions D-12  
Twist-II-Clean Filters F-7

### U

### V

Valves E-1  
VFD's B-16 thru B-29  
Volt Meter B-32

### W

Water Filters F-7  
Well Casing D-2 thru D-4  
Well Seals F-5  
Well Plates - Steel F-6

### X

### Y

### Z

ZN-18 D-37  
Zilmet Tanks C-1

# PUMPS

<b>Section</b>	<b>Page</b>
<b>4" Pumps</b>	
4" HiLo N Series Pumps	A-1
4" HiLo S Series Pumps	A-3
4" AY McDonald Pumps	A-5
<b>6-10" SS Pumps</b>	
6-10" HiLo S Series Pumps	A-11
<b>Sub-Turbine</b>	
Simflo Sub Turbine Pumps	A-13
<b>Centrifugal Pumps</b>	
Stenner Chemical Metering Pumps	A-17
AY McDonald 89000 Series Sprinkler Pumps	A-18
DAB E.Sybox Series	A-19
Zoeller Sump, Effluent & Sewage	A-20
<b>Jet Pumps</b>	
AY McDonald 8300 Series Jet Pumps	A-21



### ES "N" SERIES PUMPS

	Model	HP	Stages	Discharge	Length (PEO)	Weight (PEO)	List Price
5 GPM N-SERIES 4" PEO	5ES05N	½	12	1¼"	14.1"	7.9	\$ -
	5ES07N	¾	15	1¼"	16.2"	9.1	\$ -
	5ES10N	1	20	1¼"	19.6"	10.8	\$ -
	5ES15N	1½	26	1¼"	25.3"	12.8	\$ -
	5ES20N	2	33	1¼"	29.8"	16.1	\$ -
7 GPM N-SERIES 4" PEO	7ES05N	½	10	1¼"	13.4"	7.2	\$ -
	7ES07N	¾	13	1¼"	15.6"	9.1	\$ -
	7ES10N	1	17	1¼"	18.4"	10.2	\$ -
	7ES15N	1½	22	1¼"	22"	12.3	\$ -
	7ES20N	2	27	1¼"	26.5"	15.2	\$ -
	7ES30N	3	34	1¼"	31.7"	18.1	\$ -
10 GPM N-SERIES 4" PEO	10ES05N	½	7	1¼"	10.7"	6.2	\$ -
	10ES07N	¾	10	1¼"	12.8"	7.3	\$ -
	10ES10N	1	12	1¼"	14.1"	7.9	\$ -
	10ES15N	1½	17	1¼"	17.6"	9.7	\$ -
	10ES20N	2	20	1¼"	19.6"	10.8	\$ -
	10ES30N	3	27	1¼"	26.1"	13.2	\$ -
13 GPM N-SERIES 4" PEO	10ES50N	5	42	1¼"	36.1"	19.4	\$ -
	13ES07N	¾	7	1¼"	10.7"	6.2	\$ -
	13ES10N	1	10	1¼"	12.8"	7.1	\$ -
	13ES15N	1½	12	1¼"	14.1"	7.7	\$ -
	13ES20N	2	17	1¼"	17.6"	9.5	\$ -
	13ES30N	3	21	1¼"	20.4"	11	\$ -
18 GPM N-SERIES 4" PEO	13ES50N	5	35	1¼"	34.4"	19	\$ -
	18ES05N	½	5	1¼"	10.5"	6	\$ -
	18ES07N	¾	6	1¼"	11"	6.2	\$ -
	18ES10N	1	8	1¼"	12.7"	6.8	\$ -
	18ES15N	1½	11	1¼"	15.2"	7.9	\$ -
	18ES20N	2	14	1¼"	17.8"	9	\$ -
25 GPM N-SERIES 4" PEO	18ES30N	3	19	1¼"	22"	10.8	\$ -
	18ES50N	5	30	1¼"	32.6"	15.6	\$ -
	25ES10N	1	7	1½"	12.6"	6.9	\$ -
	25ES15N	1½	9	1½"	14.6"	7.7	\$ -
	25ES20N	2	11	1½"	16.5"	8.6	\$ -
	25ES30N	3	15	1½"	20.4"	10.3	\$ -
	25ES30N	5	26	1½"	32.5"	15.6	\$ -



**ES "N" SERIES HI CAP PUMPS**

	Model	HP	Stages	Discharge	Length (PEO)	Weight (PEO)	List Price
<b>35 GPM N-SERIES 4" PEO</b>	35ES10N	1	6	2"	14.1"	7.5	\$ -
	35ES15N	1½	8	2"	16.6"	8.8	\$ -
	35ES20N	2	10	2"	19"	10.1	\$ -
	35ES30N	3	14	2"	23.9"	12.5	\$ -
	35ES50N	5	24	2"	35.2"	17.8	\$ -
	35ES75N	7½	34	2"	49.5"	25.5	\$ -
	35ES100N	10	43	2"	51.9"	31.2	\$ -
<b>55 GPM N-SERIES 4" PEO</b>	55ES15N	1½	5	2"	17"	9.5	\$ -
	55ES20N	2	7	2"	21.1"	11.7	\$ -
	55ES30N	3	9	2"	25.2"	13.6	\$ -
	55ES50N	5	15	2"	37.5"	19.5	\$ -
	55ES75N	7½	22	2"	53"	27	\$ -
	55ES100N	10	29	2"	67.2"	34.3	\$ -
<b>80 GPM N-SERIES 4" PEO</b>	80ES30N	3	5	2"	18.6"	9.7	\$ -
	80ES50N	5	9	2"	29.3"	15.2	\$ -
	80ES75N	7½	14	2"	42.6"	21.8	\$ -
	80ES100N	10	16	2"	55.5"	27	\$ -



**SIMFLO**



**N SERIES**

- Stainless steel discharge with built-in check valve
- Stainless steel motor adapter, strainer & pump casing
- Stainless steel bowls
- Stainless steel pump shaft and coupling
- Noryl floating impellers
- Durable urethane bearings
- Available in 4" diameters
- Capacities available from 5 GPM to 80 GPM



**ES "S" SERIES PUMPS**

	Model	HP	Stages	Discharge	Length (PEO)	Weight (PEO)	List Price
<b>5 GPM S-SERIES 4" PEO</b>	5ES05S	½	13	1¼"	17.3"	8	\$ -
	5ES07S	¾	18	1¼"	21.5"	10	\$ -
	5ES10S	1	22	1¼"	24.8"	12	\$ -
	5ES15S	1½	26	1¼"	28.1"	13	\$ -
	5ES15SH	1½	31	1¼"	33.1"	20	\$ -
<b>7 GPM S-SERIES 4" PEO</b>	7ES05S	½	11	1¼"	15.2"	10	\$ -
	7ES07S	¾	15	1¼"	18.5"	11	\$ -
	7ES10S	1	19	1¼"	21.8"	12	\$ -
	7ES15S	1½	26	1¼"	27.6"	16	\$ -
	7ES20S	2	32	1¼"	34.5"	27	\$ -
<b>10 GPM S-SERIES 4" PEO</b>	10ES05S	½	9	1¼"	14"	7	\$ -
	10ES07S	¾	12	1¼"	16.5"	8	\$ -
	10ES10S	1	15	1¼"	19"	9	\$ -
	10ES15S	1½	21	1¼"	23.9"	12	\$ -
	10ES20S	2	27	1¼"	28.9"	14	\$ -
	10ES30S	3	34	1¼"	35.6"	22	\$ -
	10ES50S	5	48	1¼"	47.7"	38	\$ -
	10ES50SH	5	58	1¼"	64.5"	42	\$ -
<b>18 GPM S-SERIES 4" PEO</b>	18ES05S	½	5	1¼"	10.7"	5	\$ -
	18ES07S	¾	7	1¼"	12.4"	6	\$ -
	18ES10S	1	9	1¼"	14"	7	\$ -
	18ESL15S	1½	13	1¼"	17.3"	9	\$ -
	18ES20S	2	17	1¼"	20.6"	10	\$ -
	18ES30S	3	23	1¼"	25.6"	13	\$ -
	18ES50S	5	36	1¼"	37.2"	23	\$ -
	18ES75S	7½	56	1¼"	68.8"	45	\$ -
18ES100S	10	75	1¼"	84.5"	60	\$ -	
<b>25 GPM S-SERIES 4" PEO</b>	25ES05S	½	4	* 1½" *	9.9"	5	\$ -
	25ES07S	¾	5	* 1½" *	10.7"	5	\$ -
	25ES10S	1	7	* 1½" *	12.4"	6	\$ -
	25ES15S	1½	9	* 1½" *	14"	7	\$ -
	25ES20S	2	11	* 1½" *	15.6"	8	\$ -
	25ES30S	3	15	* 1½" *	19"	9	\$ -
	25ES50S	5	26	* 1½" *	28.3"	14	\$ -
	25ES75S	7½	39	* 1½" *	39.1"	25	\$ -
25ES100S	10	52	* 1½" *	65.5"	47	\$ -	



**ES "S" SERIES Hi Cap PUMPS**

	Model	HP	Stages	Top	Length	Weight	List Price
<b>40 GPM S-SERIES 4" PEO</b>	40ES10S	1	4	2"	14.6"	8	\$ -
	40ES15S	1½	5	2"	16.2"	9	\$ -
	40ES20S	2	7	2"	19.5"	12	\$ -
	40ES30S	3	9	2"	22.8"	14	\$ -
	40ES50S	5	15	2"	32.8"	21	\$ -
	40ES75S	7½	25	2"	49.3"	32	\$ -
	40ES100S	10	30	2"	57.5"	37	\$ -
<b>70 GPM S-SERIES 4" PEO</b>	70ES20S	2	3	2"	14.8"	8	\$ -
	70ES30S	3	5	2"	19.9"	12	\$ -
	70ES50S	5	8	2"	27.6"	16	\$ -
	70ES75S	7½	12	2"	37.8"	21	\$ -
	70ES100S	10	16	2"	48"	27	\$ -



**SIMFLO**



**S SERIES**

- Stainless steel construction
- Stainless steel discharge with built-in check valve
- High-efficiency stainless steel impellers and diffusers
- Stainless steel suction screen
- Stainless steel shaft and coupling
- Stainless steel NEMA faced mounting bracket
- Capacities available from 5 GPM to 70 GPM

**SIMFLO®**

# 4" **E/S** SERIES

PERFORMANCE AND DATA

ES "N" AND ES "S" Stainless Steel Submersibles





### SIMFLO 4" MOTORS

#### ES "N" SERIES

#### *4" Stainless Steel Submersibles with Noryl Impellers*

<b>1</b> //////////////	Motors
<b>2</b> //////////////	General Data
<b>3</b> //////////////	Cross Sectional
<b>4-5</b> //////////////	Model 5ESN
<b>6-7</b> //////////////	Model 7ESN
<b>8-9</b> //////////////	Model 10ESN
<b>10-11</b> //////////////	Model 13ESN
<b>12-13</b> //////////////	Model 18ESN
<b>14-15</b> //////////////	Model 25ESN
<b>16-17</b> //////////////	Model 35ESN
<b>18-19</b> //////////////	Model 55ESN
<b>20-21</b> //////////////	Model 80ESN

#### ES "S" SERIES

#### *4" Stainless Steel Submersibles*

<b>22-23</b> //////////////	General Data
<b>24-25</b> //////////////	Model 5ESS
<b>26-27</b> //////////////	Model 10ESS
<b>28-29</b> //////////////	Model 18ESS
<b>30-31</b> //////////////	Model 25ESS
<b>32-33</b> //////////////	Model 40ESS

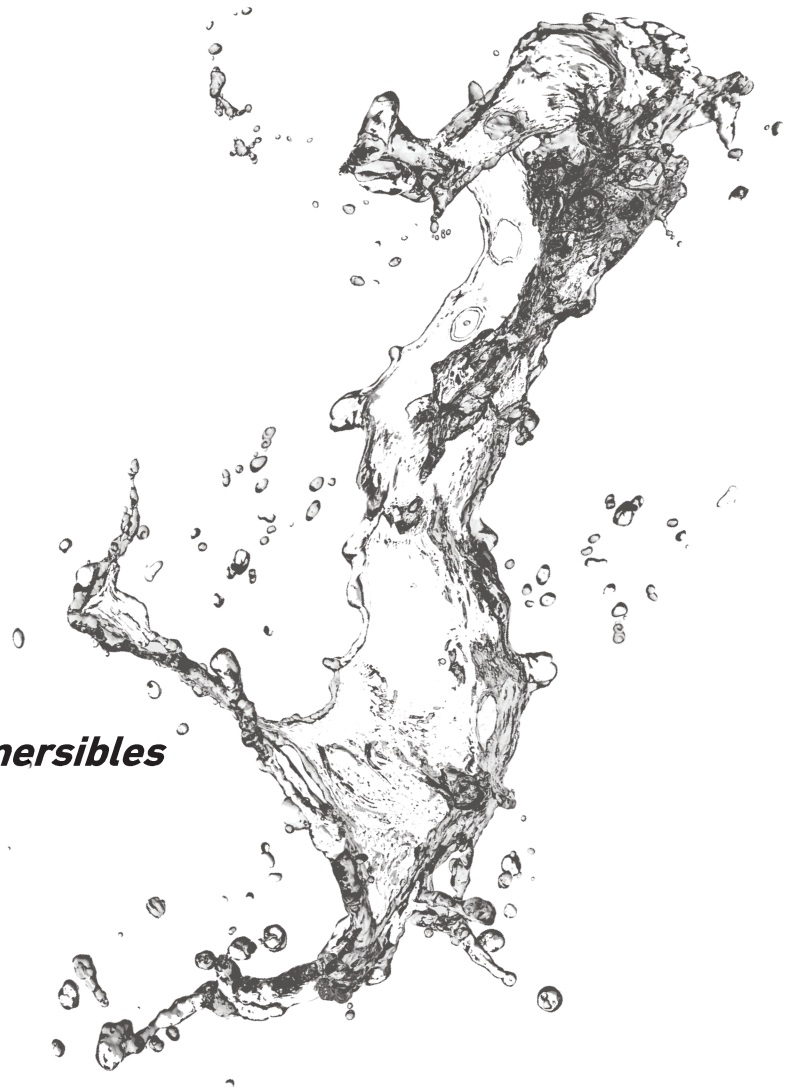



## SIMFLO 4" MOTORS

### SIMFLO 4" Motors

SIMFLO 4" Single-phased Motors												
Order Number	Type	HP	Volts	Length (IN.)	Weight (LBS.)	Thrust Load (LBS.)	AMP		Imax	EFF (%)	Cstart (uF)	S.F.
							In	Istart				
MTS.50CO.216A.SS2	2-Wire	0.5	230	10.2	16.1	337	5.5	22	6.4	57	59-71	1.60
MTS.50CO.216C.SS3	3-Wire	0.5	230	10.2"	16.1	337	5.5	22	6.4	57	59-71	1.60
MTS.75CO.216C.SS3		0.75		10.4	16.8		7	32	9.3	62	86-103	1.50
MTS.10DO.216C.SS3		1		12	20.1		8.5	40	12	58	105-126	1.40
MTS.15DO.216C.SS3		1.5		13.4	24.7	674	10.1	49	13	65	116-125	1.30
MTS.20DO.216C.SS3		2		14.8	30.9		11.6	52	15	67	116-125	1.25
MTS.30DO.216C.SS3		3		16.9	36.2		14.8	68	16.9	67	290-310	1.15
MTS.50DO.216C.SS3		5		26.6	64.6		25.5	88	27.8	69	290-310	1.15

SIMFLO 4" Three-phased Motors												
Order Number	Type	HP	Volts	Length (IN.)	Weight (LBS.)	Thrust Load (LBS.)	AMP		Imax	EFF (%)	Starting Torque (LBF.)	S.F.
							In	Istart				
MTS.10DO.236C.SS3	3-Wire	1	230	10.4	18.3	337	4.5	22.5	6.2	66	1.46	1.40
MTS.15DO.236C.SS3		1.5		11.6	24	674	5.7	31.2	7.3	71	2.09	1.30
MTS.20DO.236C.SS3		2		13.4	25.1		7.3	43.3	9	68	2.93	1.25
MTS.30DO.236C.SS3		3		14.8	31.3		10.9	60.6	12.5	70	3.98	1.15
MTS.55DO.236C.SS3		5.5		21.9	51.6	1461	17.7	95.3	20.8	78	7.49	1.15
MTS.75DO.236C.SS3		7.5		26.6	64.8		25.1	142	30	73	10.93	1.15
MTS.0100.236C.SS3		10		30.1	74.5		38.1	176.7	43.3	74	13.63	1.15
MTS.50CO.236D.SS3	3-Wire	0.5	460	9.3	12.8	337	1.2	6.8	1.6	60	0.58	1.6
MTS.75CO.236D.SS3		0.75		9.8	15.4		1.6	10.5	1.95	65	1.08	1.5
MTS.10DO.236D.SS3		1		10.4	18.3		2	12.5	2.5	67	1.46	1.4
MTS.15DO.236D.SS3		1.5		11.6	24	674	2.8	15	3.3	69	2.1	1.3
MTS.20DO.236D.SS3		2		13.4	25.1		3.5	22	4.2	71	2.93	1.25
MTS.30DO.236D.SS3		3		14.8	31.3		4.9	30.5	5.5	75	3.98	1.15
MTS.55DO.236D.SS3		5.5		21.9	51.6	1461	9	62	9.9	77	7.49	1.15
MTS.75DO.236D.SS3		7.5		26.6	64.8		12	77	13.3	77	10.93	1.15
MTS.0100.236D.SS3		10		30.1	74.5		16.2	95	18.5	77	13.63	1.15

Agency Listings:



**NEMA Motor:**

- Encapsulated resin filled stator
- Kingsbury thrust bearing
- Winding: enameled copper - Class F insulation
- IP68/Class B insulation
- Labyrinth seal, sand slinger and lip seal
- 304SS motor case and shaft

## GENERAL DATA

### ESN Model - General Data

Model	HP	Stages	Order Number	Length (IN)	Discharge	Weight (LBS)
5ESN	1/2	12	ESN.04O14.005.12.50C	14.1	1-1/4" NPT	7.9
	3/4	15	ESN.04O14.005.15.75C	16.2	1-1/4" NPT	9.0
	1	20	ESN.04O14.005.20.10D	19.6	1-1/4" NPT	10.8
	1 1/2	26	ESN.04O14.005.26.15D	25.3	1-1/4" NPT	12.8
	2	33	ESN.04O14.005.33.20D	32.3	1-1/4" NPT	18.3
7ESN	1/2	10	ESN.04O14.007.10.50C	13	1-1/4" NPT	7.3
	3/4	13	ESN.04O14.007.13.75C	15.2	1-1/4" NPT	8.4
	1	17	ESN.04O14.007.17.10D	17.9	1-1/4" NPT	9.9
	1 1/2	22	ESN.04O14.007.22.15D	21.5	1-1/4" NPT	11.9
	2	27	ESN.04O14.007.27.20D	26.6	1-1/4" NPT	14.6
	3	34	△	33.8	1-1/4" NPT	20.5
10ESN	1/2	7	ESN.04O14.010.07.50C	10.7	1-1/4" NPT	6.2
	3/4	10	ESN.04O14.010.10.75C	12.8	1-1/4" NPT	7.3
	1	12	ESN.04O14.010.12.10D	14.1	1-1/4" NPT	7.9
	1 1/2	17	ESN.04O14.010.17.15D	17.6	1-1/4" NPT	9.7
	2	20	ESN.04O14.010.20.20D	19.6	1-1/4" NPT	10.8
	3	27	ESN.04O14.010.27.30D	26	1-1/4" NPT	13.2
	5	42	ESN.04O14.010.42.50D	38.6	1-1/4" NPT	21.6
13ESN	1/2	5	ESN.04O14.013.05.50C	9.3	1-1/4" NPT	5.5
	3/4	7	△	10.7	1-1/4" NPT	6.2
	1	10	ESN.04O14.013.10.10D	12.8	1-1/4" NPT	7.1
	1 1/2	12	ESN.04O14.013.12.15D	14.1	1-1/4" NPT	7.7
	2	17	ESN.04O14.013.17.20D	17.6	1-1/4" NPT	9.5
	3	21	ESN.04O14.013.21.30D	20.4	1-1/4" NPT	11
	5	35	ESN.04O14.013.35.50D	33.7	1-1/4" NPT	19
18ESN	1/2	5	ESN.04O14.018.05.50C	10.1	1-1/4" NPT	6
	3/4	6	ESN.04O14.018.06.75C	11	1-1/4" NPT	6.2
	1	8	ESN.04O14.018.08.10D	12.7	1-1/4" NPT	6.8
	1 1/2	11	ESN.04O14.018.11.15D	15.2	1-1/4" NPT	7.9
	2	14	ESN.04O14.018.14.20D	17.8	1-1/4" NPT	9
	3	19	ESN.04O14.018.19.30D	22	1-1/4" NPT	10.8
	5	30	ESN.04O14.018.30.50D	34.8	1-1/4" NPT	17.9

\*Contact Factory for product availability outside of listings

Model	HP	Stages	Order Number	Length (IN)	Discharge	Weight (LBS)
25ESN	1/2	4	ESN.04O18.025.04.50C	9.7	1-1/2" NPT	5.3
	3/4	5	ESN.04O18.025.05.75C	10.7	1-1/2" NPT	5.7
	1	7	△	12.6	1-1/2" NPT	6.8
	1 1/2	9	ESN.04O18.025.09.15D	14.6	1-1/2" NPT	7.7
	2	11	ESN.04O18.025.11.20D	16.5	1-1/2" NPT	8.6
	3	15	ESN.04O18.025.15.30D	20.4	1-1/2" NPT	10.4
	5	26	ESN.04O18.025.26.50D	34	1-1/2" NPT	17.9
35ESN	1	6	△	14.1	2" NPT	7.5
	1 1/2	8	ESN.04O20.035.08.15D	16.6	2" NPT	8.8
	2	10	ESN.04O20.035.10.20D	19	2" NPT	10.1
	3	14	ESN.04O20.035.14.30D	23.9	2" NPT	12.6
	5	22	ESN.04O20.035.22.50D	35.2	2" NPT	17.9
	7 1/2	34	ESN.04O20.035.34.75D	52.2	2" NPT	27.8
	10	43	ESN.04O20.035.43.010	66	2" NPT	33.5
55ESN	1 1/2	5	△	17	2" NPT	9.5
	2	7	ESN.04O20.055.07.20D	21.1	2" NPT	11.7
	3	9	ESN.04O20.055.09.30D	25.2	2" NPT	13.7
	5	15	ESN.04O20.055.15.50D	37.5	2" NPT	19.8
	7 1/2	22	ESN.04O20.055.22.75D	55.5	2" NPT	29.3
	10	29	ESN.04O20.055.29.010	69.9	2" NPT	36.6
80ESN	3	5	△	18.6	2" NPT	9.7
	5	9	ESN.04O20.080.09.50D	29.3	2" NPT	15.2
	7 1/2	14	ESN.04O20.080.14.75D	42.6	2" NPT	21.8

Rotation is Counterclockwise when observed from pump discharge end

#### Agency Listing



Drinking Water NSF/ANSI 61  
NSF/ANSI 372

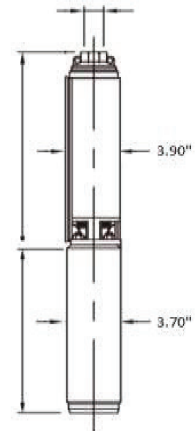

#### Features:

Stainless steel construction designed and built for years of trouble free operation.

Floating type impellers made with Noryl® for superior sand handling.

304 Stainless steel hex bar pumpshaft for high corrosion resistance.

Pump body covered by a 4" 1.5mm/6" 2.0mm thick 304SS polished casing, ensuring optimum resistance to abrasion.

Heavy duty stainless steel discharge with built-in check valve to help prevent back flow and alleviate water hammer.

Polyacetal bearings for stong wear and abrasive resistance.

Sand Content: Max. 150g/m<sup>3</sup>

Polyacetal bearings for stong wear and abrasive resistance.

NEMA standard motor adaptor.

## CROSS SECTIONAL

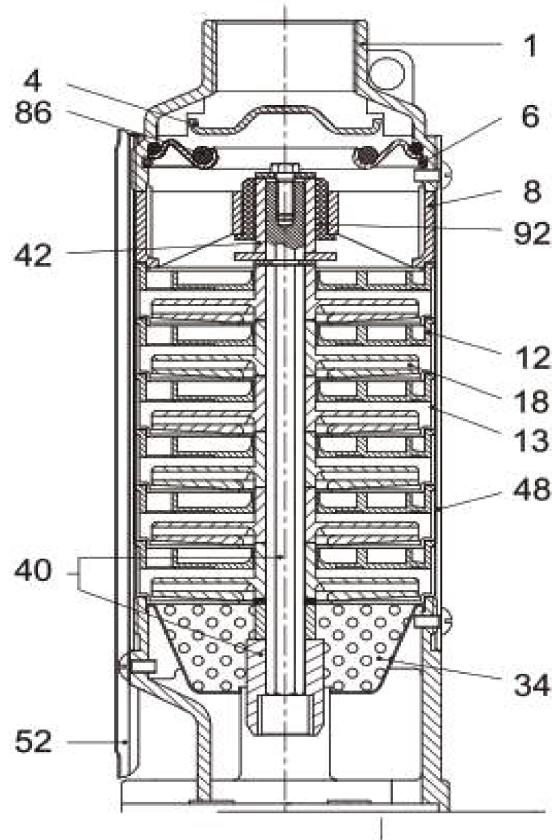

Pos.	Part Name	Materials
1	Discharge	AISI 304 SS
4	Check Valve Cone	AISI 304 SS
6	Check Valve Retaining Ring	AISI 304 SS
8	Bearing Spider	Glass Filled Polycarbonate
12	Diffuser	Glass Filled Polycarbonate
13	Bowl	AISI 304 SS
18	Impeller	Noryl
34	Strainer	AISI 304 SS
40	Pump Shaft / Coupling	AISI 304 SS
42	Shaft Sleeve	AISI 304 SS or Noryl
48	Pump Shell	AISI 304 SS
52	Cable Guard	AISI 304 SS
86	O-Ring	NBR
92	Bearing	Polyacetal

# MODEL 5ESN

## PERFORMANCE CURVES

# SIMFLO®

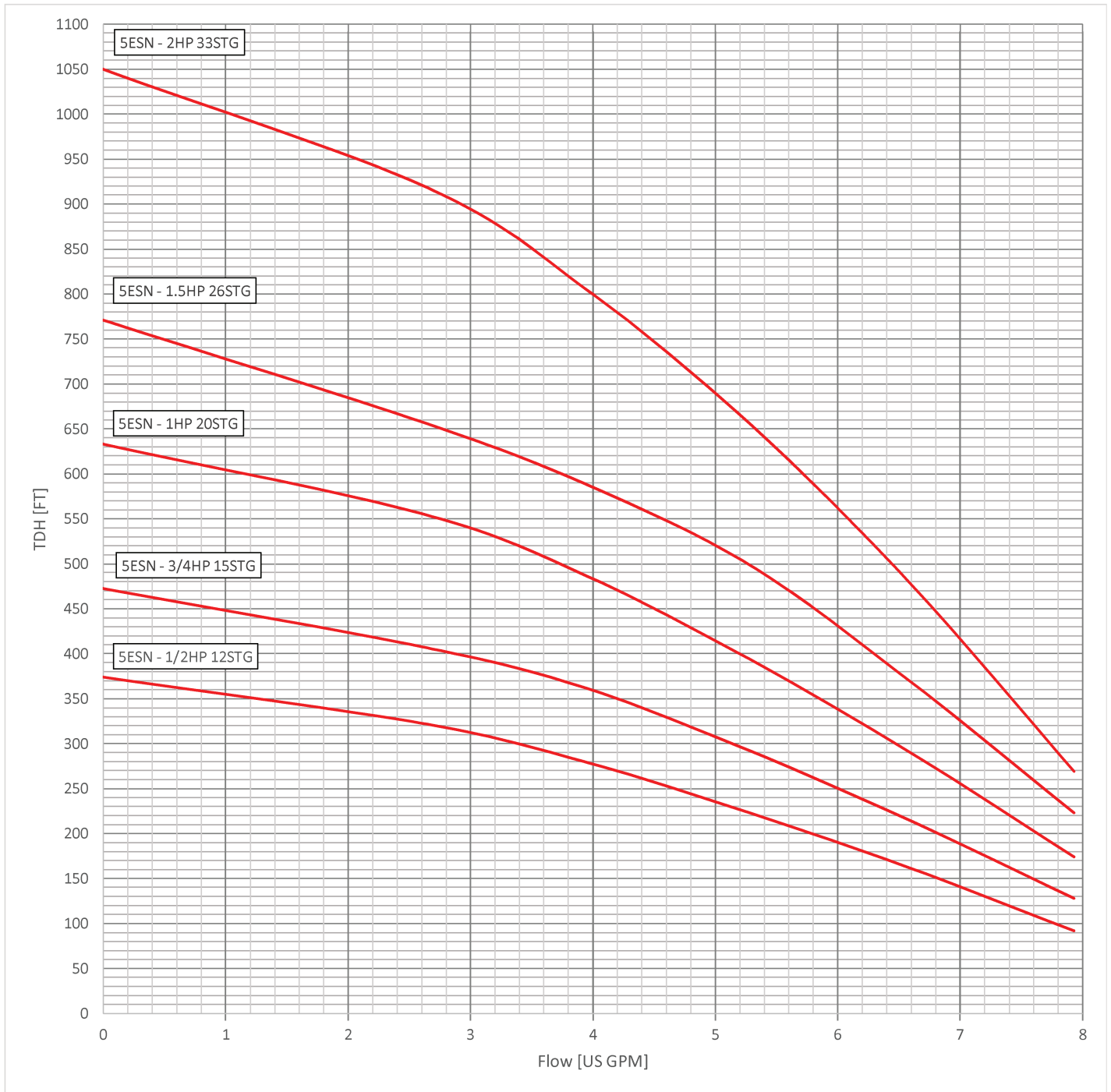

# MODEL 5ESN



## SECTIONAL CHART

Pump Model	HP	PSI	Depth to Pumping Water Level [FT]/ Flow [GPM]															
			0	20	40	60	80	100	120	140	160	180	200	220	240	260	300	340
5ESN -12STG	1/2	0								7	6.7	6.3	5.8	5.4	4.9	4.4	3.3	1.9
		20						6.9	6.5	6.1	5.7	5.3	4.8	4.3	3.7	3.1	1.6	
		30				7.2	6.9	6.5	6.1	5.6	5.2	4.7	4.2	3.6	3	2.3		
		40			7.2	6.8	6.4	6	5.6	5.1	4.6	4.1	3.5	2.9	2.2			
		50		7.1	6.7	6.4	5.9	5.5	5	4.5	4	3.4	2.8	2.1				
		60	7.1	6.7	6.3	5.9	5.4	5	4.5	3.9	3.3	2.7	1.9					
Shut-off PSI			162	153	145	136	127	119	110	101	93	84	75	67	58	49	32	15

Pump Model	HP	PSI	Depth to Pumping Water Level [FT]/ Flow [GPM]															
			20	40	60	80	100	120	140	160	180	200	220	240	280	320	380	420
5ESN - 15STG	3/4	0								7.2	6.9	6.5	6.2	5.9	5.2	4.3	3.4	2.3
		20						7.1	6.8	6.4	6.1	5.8	5.4	5	4.2	3.2	2.1	
		30					7	6.7	6.4	6.1	5.7	5.4	5	4.6	3.7	2.6		
		40				7	6.7	6.3	6	5.7	5.3	4.9	4.5	4.1	3.1	1.9		
		50			6.9	6.6	6.3	6	5.6	5.2	4.8	4.4	4	3.5	2.4			
		60	7.2	6.9	6.6	6.2	5.9	5.5	5.2	4.8	4.4	3.9	3.4	2.9	1.6			
Shut-off PSI			196	187	179	170	161	153	144	135	127	118	109	101	83	66	40	23

Pump Model	HP	PSI	Depth to Pumping Water Level [FT]/ Flow [GPM]															
			100	120	140	160	180	200	220	260	300	340	380	420	460	500	540	580
5ESN - 20STG	1	0								7	6.5	6	5.5	5	4.3	3.7	2.9	2
		20						7.1	6.9	6.4	6	5.4	4.9	4.2	3.6	2.8	1.6	
		30					7.1	6.9	6.6	6.2	5.7	5.1	4.5	3.9	3.1	2.2		
		40				7.1	6.8	6.6	6.4	5.9	5.3	4.8	4.1	3.4	2.6	1.6		
		50			7	6.8	6.6	6.3	6.1	5.6	5	4.4	3.7	3	2.1			
		60	7.2	7	6.8	6.5	6.3	6.1	5.8	5.3	4.7	4	3.3	2.5				
Shut-off PSI			231	222	214	205	196	188	179	162	144	127	110	92	75	58	40	23

Pump Model	HP	PSI	Depth to Pumping Water Level [FT]/ Flow [GPM]															
			180	200	220	240	260	280	320	360	400	440	480	520	560	600	640	680
5ESN - 26STG	1 1/2	0							7.1	6.7	6.3	5.8	5.4	4.9	4.4	3.8	3	2.1
		20						7	6.6	6.2	5.8	5.3	4.8	4.3	3.7	2.9	1.9	
		30					7	6.8	6.4	6	5.5	5	4.5	3.9	3.2	2.3		
		40				7	6.8	6.6	6.1	5.7	5.2	4.7	4.2	3.6	2.7	1.8		
		50		7.1	6.9	6.7	6.5	6.3	5.9	5.4	4.9	4.4	3.8	3	2.2			
		60	7.1	6.9	6.7	6.5	6.3	6.1	5.6	5.1	4.6	4.1	3.5	2.4				
Shut-off PSI			256	247	239	230	221	213	195	178	161	143	126	109	91	74	57	39

  

Pump Model	HP	PSI	Depth to Pumping Water Level [FT]/ Flow [GPM]															
			280	320	360	400	440	480	520	560	600	640	680	720	780	840	900	960
5ESN - 33STG	2	0				7.1	6.9	6.6	6.3	6	5.7	5.4	5.1	4.7	4.2	3.6	2.9	1.8
		20			7.1	6.8	6.6	6.3	6	5.7	5.4	5	4.7	4.3	3.7	3	2.1	
		30		7.2	6.9	6.7	6.4	6.1	5.8	5.5	5.2	4.8	4.5	4.1	3.5	2.7	1.7	
		40		7	6.8	6.5	6.2	5.9	5.6	5.3	5	4.6	4.3	3.9	3.2	2.4	1.1	
		50	7.2	6.9	6.6	6.3	6.1	5.8	5.5	5.1	4.8	4.4	4	3.6	2.9	1.9		
		60	7	6.7	6.5	6.2	5.9	5.6	5.3	4.9	4.6	4.2	3.8	3.4	2.6	1.4		
Shut-off PSI			333	316	299	281	264	247	229	212	195	177	160	143	117	91	65	39

# MODEL 7ESN

## PERFORMANCE CURVES

# SIMFLO®

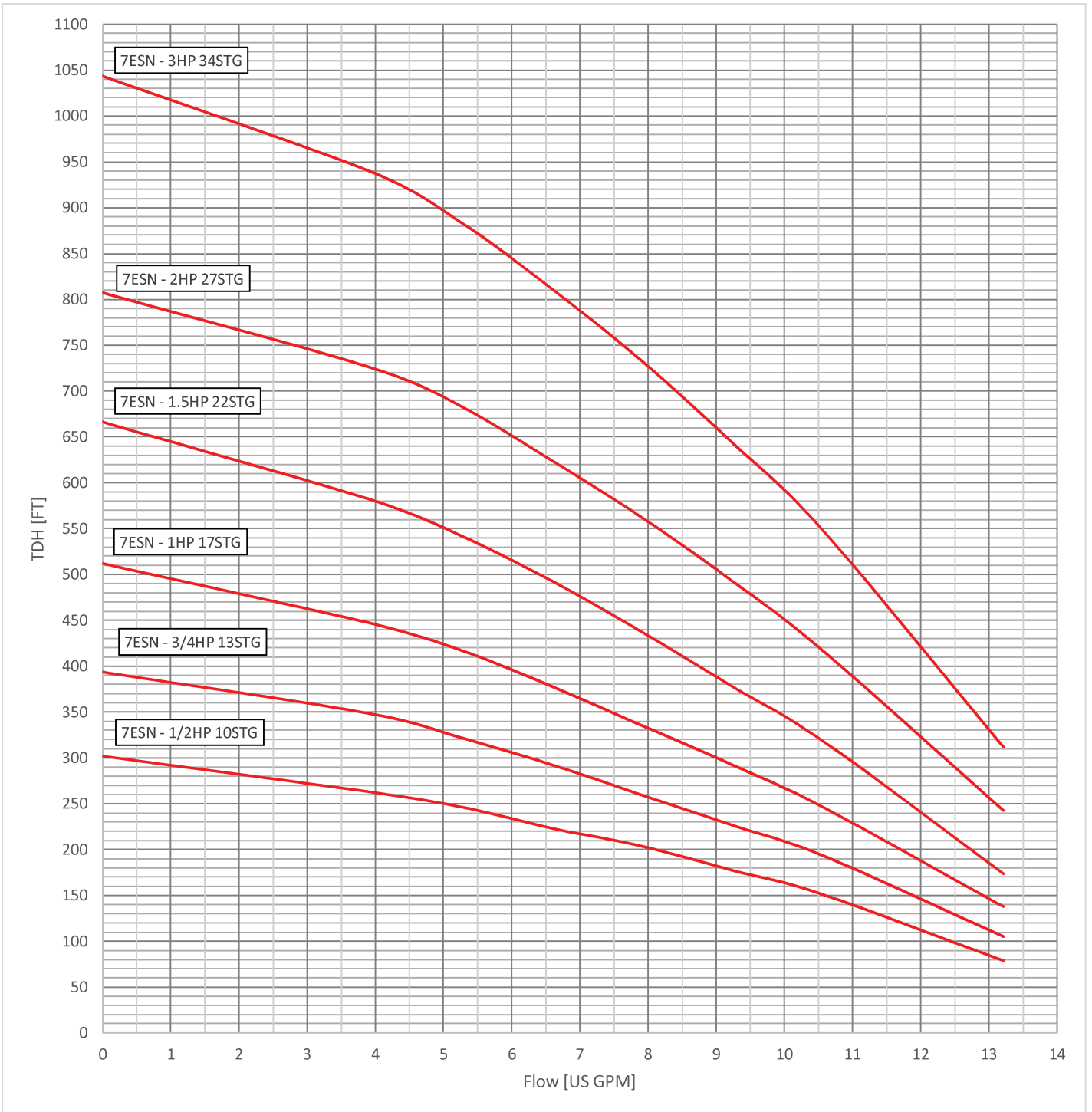



## SECTIONAL CHART

Pump Model	HP	PSI	Depth to Pumping Water Level [FT]/ Flow [GPM]															
			0	20	40	60	80	100	120	140	160	180	200	220	240	260	270	280
7ESN - 10STG	1/2	0							11.7	10.9	10	9.1	8.1	6.9	5.7	4.3	3.5	2.6
		20					11.5	10.6	9.7	8.8	7.7	6.6	5.3	3.8	1.9			
		30				11.3	10.5	9.6	8.6	7.6	6.4	5.1	3.5					
		40			11.2	10.3	9.4	8.4	7.4	6.2	4.9	3.3						
		50		11.1	10.2	9.3	8.3	7.2	6	4.6	3							
		60	10.9	10.1	9.1	8.1	7	5.8	4.4	2.7								
Shut-off PSI			131	122	113	105	96	87	79	70	61	53	44	35	27	18	14	9
Pump Model	HP	PSI	Depth to Pumping Water Level [FT]/ Flow [GPM]															
			40	60	80	100	120	140	160	180	200	220	240	260	280	300	320	360
7ESN - 13STG	3/4	0								10.9	10.3	9.5	8.8	8	7.2	6.3	5.3	3
		20						10.7	10	9.3	8.6	7.8	6.9	6	5	3.8	2.5	
		30				11.3	10.6	9.9	9.2	8.5	7.6	6.8	5.8	4.8	3.7	2.3		
		40			11.2	10.5	9.8	9.1	8.3	7.5	6.6	5.7	4.6	3.5	2.1			
		50		11.1	10.4	9.7	9	8.2	7.4	6.5	5.5	4.5	3.3	1.8				
		60	11	10.3	9.6	8.9	8.1	7.3	6.4	5.4	4.3	3.1						
Shut-off PSI			153	144	136	127	118	110	101	93	84	75	67	58	49	41	32	15
Pump Model	HP	PSI	Depth to Pumping Water Level [FT]/ Flow [GPM]															
			80	100	120	140	160	180	200	220	240	260	280	300	340	380	420	460
7ESN - 17STG	1	0								11.2	10.7	10.2	9.6	9.1	7.9	6.5	5	3.2
		20						11.1	10.6	10	9.5	8.9	8.3	7.7	6.3	4.8	2.9	
		30					11	10.5	9.9	9.4	8.8	8.2	7.6	6.9	5.4	3.7		
		40				10.9	10.4	9.9	9.3	8.7	8.1	7.5	6.8	6.1	4.5	2.4		
		50			10.8	10.3	9.8	9.2	8.6	8	7.4	6.7	6	5.2	3.5			
		60	11.3	10.8	10.2	9.7	9.1	8.5	7.9	7.3	6.6	5.8	5.1	4.2	2.6			
Shut-off PSI			187	178	170	161	152	144	135	126	118	109	100	92	74	57	40	22
Pump Model	HP	PSI	Depth to Pumping Water Level [FT]/ Flow [GPM]															
			140	160	180	200	220	240	260	280	320	360	400	440	480	520	560	600
7ESN - 22STG	1 1/2	0								11.3	10.5	9.7	8.8	7.9	6.9	5.8	4.6	3.2
		20						11.2	10.8	10.4	9.6	8.7	7.8	6.7	5.6	4.4	3	
		30					11.1	10.7	10.3	9.9	9.1	8.2	7.2	6.1	4.9	3.6		
		40				11.1	10.7	10.3	9.9	9.4	8.6	7.6	6.6	5.5	4.2	2.5		
		50			11	10.6	10.2	9.8	9.4	8.9	8	7	5.9	4.7	3.4			
		60	11.3	10.9	10.5	10.1	9.7	9.3	8.9	8.4	7.5	6.4	5.3	4	2.2			
Shut-off PSI			228	219	210	202	193	184	176	167	150	132	115	98	81	63	46	29
Pump Model	HP	PSI	Depth to Pumping Water Level [FT]/ Flow [GPM]															
			240	260	280	300	320	360	400	440	480	520	560	600	640	680	720	760
7ESN - 2HP	2	0						11.5	10.9	10.2	9.5	8.8	8	7.2	6.2	5.2	4	2.2
		20					11.4	10.8	10.1	9.4	8.7	7.9	7	6.1	5	3.8	2	
		30				11.3	11	10.4	9.7	9	8.2	7.4	6.5	5.5	4.4	3		
		40			11.3	11	10.7	10	9.3	8.5	7.7	6.9	5.9	4.9	3.6	1.6		
		50		11.2	10.9	10.6	10.3	9.6	8.9	8.1	7.3	6.3	5.3	4.2	2.4			
		60	11.2	10.9	10.6	10.2	9.9	9.2	8.4	7.6	6.7	5.8	4.7	3.4				
Shut-off PSI			245	237	228	220	211	194	176	159	142	124	107	90	72	55	38	20
Pump Model	HP	PSI	Depth to Pumping Water Level [FT]/ Flow [GPM]															
			360	400	440	480	520	560	600	640	680	720	760	800	840	880	920	980
7ESN - 34 STG	3	0				11.4	10.9	10.4	9.9	9.3	8.7	8.1	7.5	6.8	6.1	5.3	4.4	2.4
		20			11.3	10.8	10.3	9.8	9.2	8.7	8	7.4	6.7	6	5.2	4.2	2.8	
		30		11.5	11	10.5	10	9.5	8.9	8.3	7.7	7	6.3	5.5	4.6	3.6	2	
		40		11.2	10.7	10.2	9.7	9.1	8.6	7.9	7.3	6.6	5.9	5	4.1	2.6		
		50	11.4	10.9	10.4	9.9	9.4	8.8	8.2	7.6	6.9	6.2	5.4	4.5	3.2	1.8		
		60	11.1	10.6	10.1	9.6	9.1	8.5	7.9	7.2	6.5	5.7	4.9	3.9	2.4			
Shut-off PSI			296	278	261	244	227	209	192	175	157	140	123	105	88	71	53	27

# MODEL 10ESN

# SIMFLO®

## PERFORMANCE CURVES

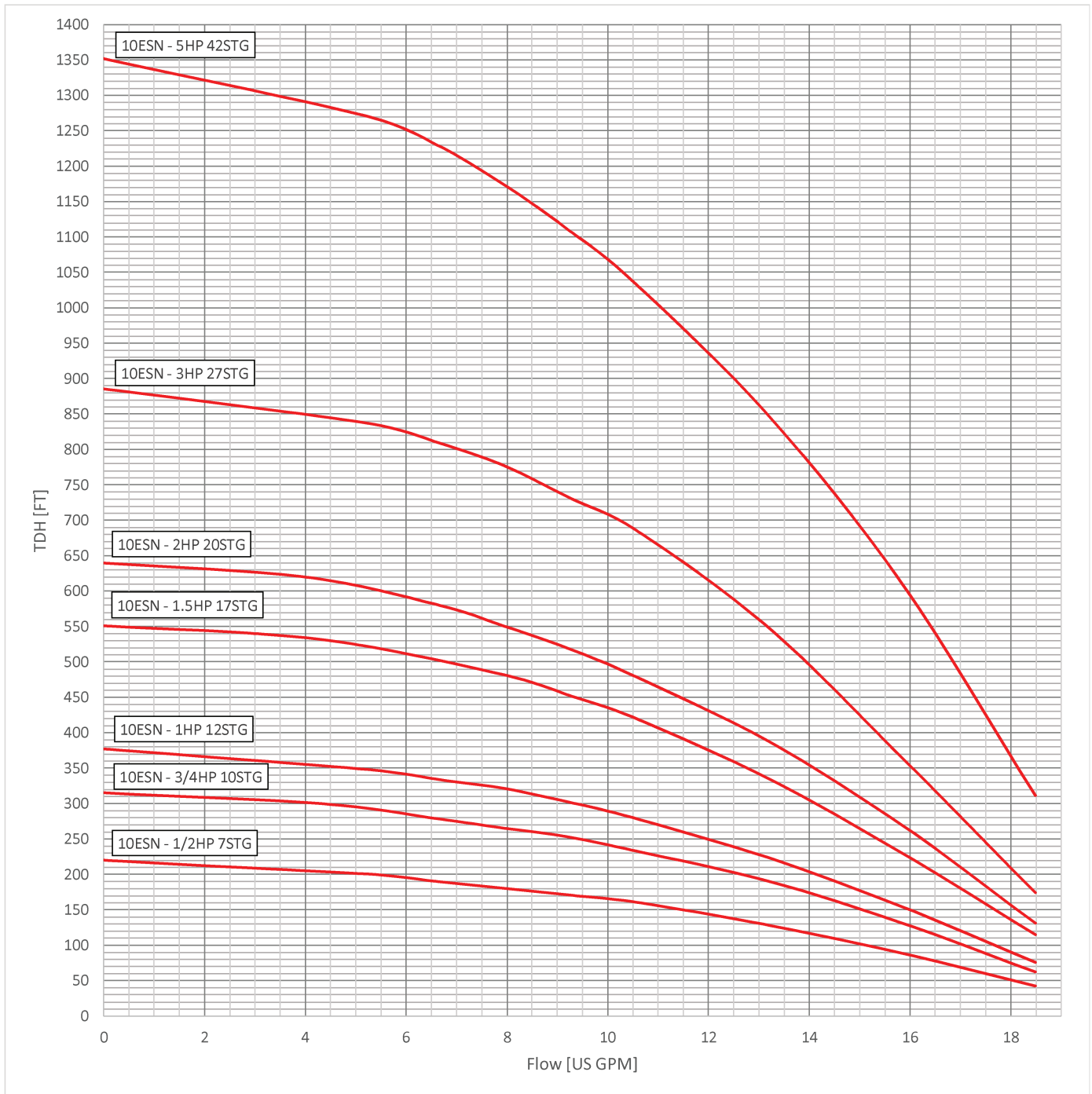

# MODEL 10ESN



## SECTIONAL CHART

Pump Model	HP	PSI	Depth to Pumping Water Level [FT]/ Flow [GPM]															
			0	10	20	30	40	50	60	70	80	90	100	120	140	160	200	
10ESN - 7STG	1/2	0									17	16.4	15.7	15.1	13.7	12.1	10.3	5.3
		20				16.6	16	15.3	14.7	13.9	13.2	12.4	11.6	9.7	7.4	4.2		
		30		16.4	15.8	15.1	14.4	13.7	12.9	12.1	11.3	10.4	9.4	7	3.4			
		40	15.6	14.9	14.2	13.5	12.7	11.9	11	10.1	9	7.9	6.5	2.6				
		50	14	13.2	12.5	11.6	10.7	9.7	8.7	7.5	6.1	4.3						
		60	12.2	11.3	10.4	9.4	8.3	7.1	5.6	3.6								
Shut-off PSI			95	91	86	82	78	74	69	65	61	56	52	43	35	26	9	

Pump Model	HP	PSI	Depth to Pumping Water Level [FT]/ Flow [GPM]																	
			20	40	60	80	100	120	140	160	180	200	220	240	260	280	300			
10ESN - 10STG	3/4	0									16.3	15.4	14.5	13.5	12.5	11.3	10.1	8.6	6.8	4.3
		20				16	15.1	14.4	13.4	12.4	11	9.8	7.8	5.9						
		30			15.9	15.2	14.3	13.3	12.1	10.8	9.7	7.7	4.6							
		40		15.7	14.9	14	12.8	11.9	10.5	9.3	7.1	4.8								
		50	15.6	14.8	14	13	11.6	10.4	9	6.5	4.6									
		60	14.5	13.6	12.7	11.3	10	8.7	6.4	4.2										
Shut-off PSI			128	119	110	102	93	84	76	67	58	50	41	32	24	15	6			

Pump Model	HP	PSI	Depth to Pumping Water Level [FT]/ Flow [GPM]															
			20	40	60	80	100	120	140	160	180	200	220	240	260	300	340	
10ESN - 12STG	1	0									15.6	14.8	14	13.4	12.4	11.6	9.4	6
		20						15.6	14.7	13.9	13	12.1	11.2	10.2	9	5.5		
		30				16	15.2	14.5	13.8	13	12	11	10	8.8	7			
		40			15.9	15.2	14.4	13.6	12.7	11.8	11	9.6	8.4	6.6	4			
		50	15.8	15	14.3	13.5	12.6	11.6	10.7	9.6	8.3	7.4	3.8					
		60	15.7	15	14.2	13.4	12.5	11.6	10.6	9.4	8.2	6.2	2.9					
Shut-off PSI			155	146	137	129	120	111	103	94	85	77	68	59	51	33	16	

Pump Model	HP	PSI	Depth to Pumping Water Level [FT]/ Flow [GPM]															
			140	160	180	200	220	240	260	280	280	300	340	380	420	460	540	
10ESN - 17STG	1 1/2	0									14.7	14.7	14.2	13.1	11.9	10.5	8.9	3.6
		20						14.6	14	13.5	13.5	12.9	11.7	10.3	8.6	6.5		
		30				15	14.5	13.9	13.4	12.8	12.8	12.2	10.9	9.3	7.4	4.7		
		40			14.9	14.4	13.9	13.3	12.7	12.1	12.1	11.5	10	8.3	6.1	2.1		
		50	14.8	14.3	13.8	13.2	12.6	12	11.3	11.3	10.6	9.1	7.1	4.1				
		60	14.8	14.2	13.7	13.1	12.5	11.9	11.2	10.5	10.5	9.8	8	5.6				
Shut-off PSI			178	169	161	152	143	135	126	117	117	109	91	74	57	39	5	

Pump Model	HP	PSI	Depth to Pumping Water Level [FT]/ Flow [GPM]																	
			140	160	180	200	220	240	260	280	300	320	340	400	460	500	560	620		
10ESN - 20STG	2	0									16	15.6	15.2	14.8	14.3	12.8	11.2	9.9	7.6	4
		20					15.9	15.5	15.1	14.6	14.2	13.7	13.2	11.6	9.7	8.2	5.1			
		30				15.9	15.4	15	14.5	14.1	13.6	13.1	12.6	10.9	8.9	7.2	3			
		40			15.8	15.4	14.9	14.5	14	13.5	13	12.5	12	10.2	7.9	6				
		50	16.1	15.7	15.3	14.9	14.4	13.9	13.5	13	12.4	11.9	11.3	9.4	6.9	4.4				
		60	15.7	15.2	14.8	14.3	13.9	13.4	12.9	12.3	11.8	11.2	10.6	8.5	5.6					
Shut-off PSI			216	208	199	190	182	173	164	156	147	138	130	104	78	61	35	9		

Pump Model	HP	PSI	Depth to Pumping Water Level [FT]/ Flow [GPM]																			
			220	260	300	340	380	420	460	500	540	560	580	600	620	660	700	720	760	800	840	860
10ESN - 27STG	3	0					15.8	15.2	14.6	13.9	13.2	12.9	12.5	12.1	11.7	10.9	10	9.5	8.4	7	4.8	3
		20				15.7	15.1	14.5	13.8	13.1	12.4	12	11.6	11.2	10.8	9.9	8.8	8.3	6.8	4.2		
		30			15.9	15.3	14.7	14.1	13.4	12.7	12	11.6	11.1	10.7	10.3	9.3	8.2	7.5	5.6			
		40		16.1	15.6	15	14.4	13.7	13	12.3	11.5	11.1	10.6	10.2	9.7	8.7	7.4	6.7	3.4			
		50	15.8	15.2	14.6	14	13.3	12.6	11.8	11	10.6	10.1	9.6	9.1	8	6.3	5.1					
		60	16.1	15.5	14.9	14.3	13.6	12.9	12.2	11.4	10.5	10	9.6	9	8.5	7	5.2					
Shut-off PSI			288	271	254	236	219	202	184	167	150	141	132	124	115	98	80	72	54	37	20	11

Pump Model	HP	PSI	Depth to Pumping Water Level [FT]/ Flow [GPM]																					
			460	500	540	580	620	660	700	740	780	820	860	900	940	980	1020	1060	1100	1140	1180	1220	1260	40
10ESN - 42STG	5	0					15.7	15.2	14.8	14.4	13.9	13.4	12.9	12.4	11.9	11.3	10.7	10.1	9.4	8.7	7.9	6.9	5.9	3.4
		20				15.6	15.2	14.8	14.3	13.8	13.4	12.9	12.3	11.8	11.2	10.6	10	9.3	8.6	7.7	6.8	5.4	3	
		30			15.8	15.4	14.9	14.5	14	13.6	13.1	12.6	12	11.5	10.9	10.3	9.6	8.9	8.1	7.2	6.2	3.8		
		40			15.5	15.1	14.7	14.2	13.8	13.3	12.8	12.3	11.7	11.1	10.5	9.9	9.2	8.4	7.6	6.6	5			
		50	15.7	15.3	14.9	14.4	14	13.5	13	12.5	12	11.4	10.8	10.2	9.5	8.8	8	7.1	5.8	3.6				
		60	15.9	15.5	15.1	14.6	14.2	13.7	13.2	12.7	12.2	11.6	11.1	10.4	9.8	9.1	8.3	7.5	6.3	4.6				
Shut-off PSI			386	369	351	334	317	299	282	265	247	230	213	196	178	161	144	126	109	92	74	57	40	568

# MODEL 13ESN

# SIMFLO®

## PERFORMANCE CURVES

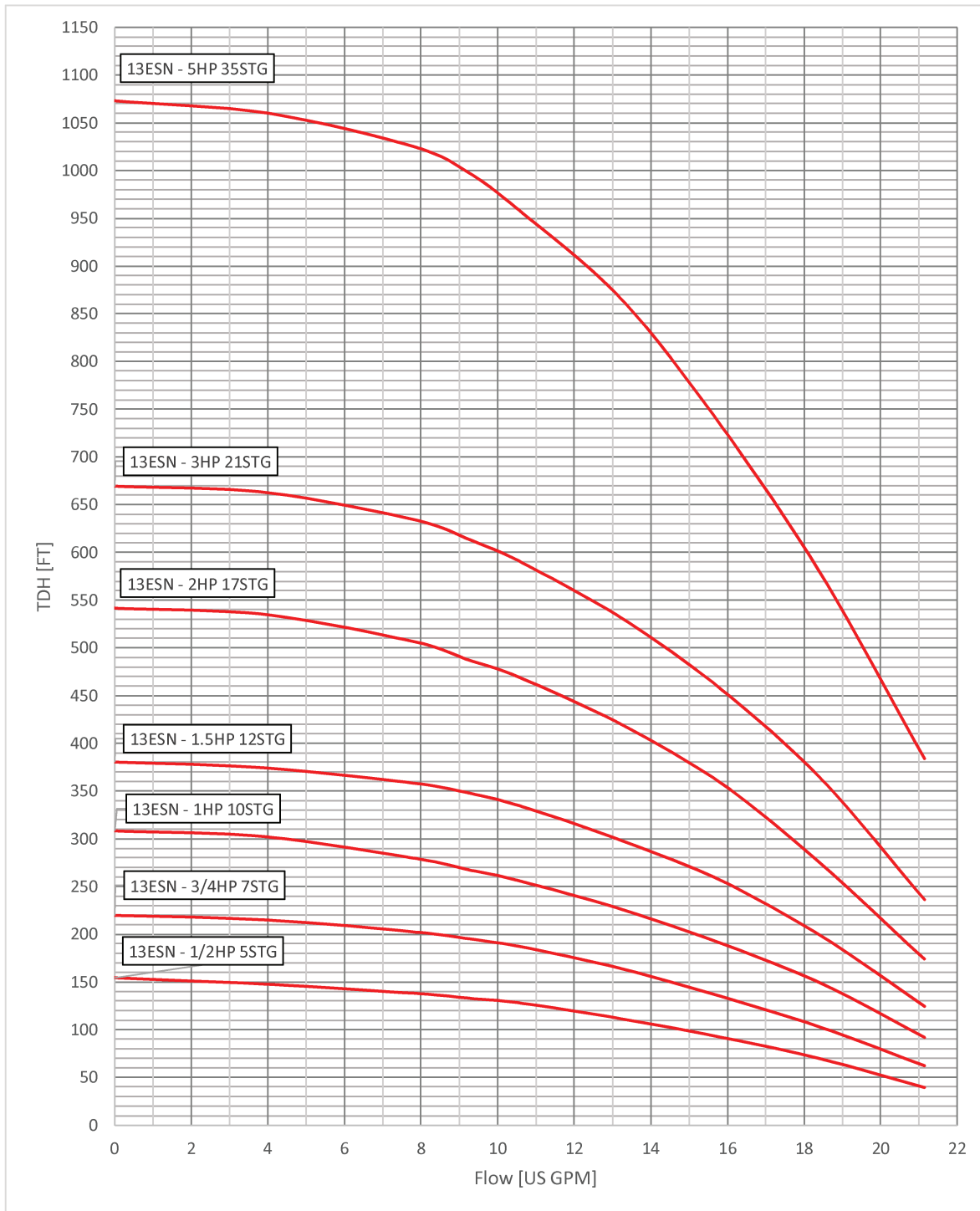

# MODEL 13ESN



## SECTIONAL CHART

Pump Model	HP	PSI	Depth to Pumping Water Level [FT]/ Flow [GPM]								
			20	40	60	80	100	120	140		
13ESN - 5STG	1/2	0			19	17	14.6	11.8	6.4		
		20	18.8	16.4	13.8	10.8	4.6				
		30	16	13.2	10	2					
		40	13	9.4	1.5						
		50	8.6								
		60	4								
Shut-off PSI			58	49	41	32	23	15	6		

Pump Model	HP	PSI	Depth to Pumping Water Level [FT]/ Flow [GPM]									
			0	20	40	60	80	110	130	150	170	210
13ESN - 7STG	3/4	0					20	17.9	16.3	14.5	12.4	6.1
		20		20.9	19.6	18.2	16.6	13.9	11.7	8.9	4	
		30		19.4	17.9	16.3	14.6	11.3	8.4	2.4	8.5	
		40	19.2	17.7	16.1	14.3	12.2	7.8				
		50	17.5	15.8	14	11.8	9					
		60	15.6	13.7	11.4	8.5						
Shut-off PSI			95	86	78	69	61	48	39	30	22	4

Pump Model	HP	PSI	Depth to Pumping Water Level [FT]/ Flow [GPM]															
			20	40	60	80	100	120	140	160	180	200	220	240	260	280	300	
13ESN - 10STG	1	0								18.8	17.6	16.4	15.1	13.7	12.1	10.2	7.9	4.4
		20					18.4	17.3	16	14.7	13.2	11.5	9.5	7				
		30				18.3	17.1	15.8	14.5	13	11.2	9.2	6.5					
		40			18.1	16.9	15.6	14.2	12.7	10.9	8.8	6						
		50	17.9	16.7	15.4	14	12.5	10.6	8.5	5.4								
		60	17.7	16.5	15.2	13.8	12.2	10.3	8.1	4.7								
Shut-off PSI			125	116	108	99	90	82	73	64	56	47	38	30	21	12	4	

Pump Model	HP	PSI	Depth to Pumping Water Level [FT]/ Flow [GPM]														
			40	60	80	100	120	140	160	180	200	220	240	260	280	320	360
13ESN - 12STG	1 1/2	0								19.1	18.3	17.4	16.4	15.4	14.3	11.7	7.9
		20					18.9	18	17.1	16.1	15.1	13.9	12.7	11.2	7		
		30				18.7	17.9	16.9	16	14.9	13.7	12.4	10.9	9.1			
		40			18.6	17.7	16.8	15.8	14.7	13.5	12.2	10.7	8.8	6			
		50	19.3	18.5	17.6	16.7	15.6	14.6	13.4	12	10.4	8.4	5.3				
		60	19.2	18.3	17.4	16.5	15.5	14.4	13.2	11.8	10.2	8.1	4.4				
Shut-off PSI			147	139	130	121	113	104	95	87	78	70	61	52	44	26	9

Pump Model	HP	PSI	Depth to Pumping Water Level [FT]/ Flow [GPM]																		
			120	160	200	240	280	320	340	360	380	400	420	440	460	480	500	520			
13ESN - 17STG	2	0								18.3	17.1	16.5	15.8	15	15.1	13.2	12.2	11	9.8	8.2	6
		20				18.2	16.9	15.5	14.8	13.9	12.7	11.8	10.2	9.2	7.8	4.6					
		30			18.7	17.5	16.2	14.7	13.8	12.8	11.5	10.6	9.1	7.5	4.8						
		40	18.9	13.1	16.7	15.3	13.5	12.7	11.5	10.4	9.3	6.9	4.4								
		50	18.5	11.8	16	14.3	12.4	11.5	10	8.6	6.8	4									
		60	18.8	17.7	10.3	14.9	13.4	11	10.1	8.4	6.4	3.8									
Shut-off PSI			182	165	148	130	113	96	87	78	70	61	53	44	35	27	18	9			

Pump Model	HP	PSI	Depth to Pumping Water Level [FT]/ Flow [GPM]																
			200	220	240	260	280	300	320	340	360	380	420	460	500	540	580	620	660
13ESN - 21STG	3	0								18.9	18.5	18	16.9	15.7	14.5	12.9	11	9	4.6
		20					18.7	18.5	17.9	17.2	16.7	15.9	14.2	12.6	11.8	8.6	3.8		
		30				18.6	18.4	17.8	17.2	16.6	16	14.8	13.4	11.7	9.7	6.2			
		40			18.6	18.2	17.9	17	16.5	15.9	15.3	13.9	12.3	10.2	7.8				
		50	19	19.1	18.2	17.6	17	16.3	15.9	15.2	14.5	13.1	11.2	9.1	5.4				
		60	19.1	18.5	17.9	17.4	16.8	16.5	15.8	15	14.4	13.8	12.1	10.2	7.2				
Shut-off PSI			203	194	186	177	169	160	151	143	134	125	108	91	73	56	39	21	4

Pump Model	HP	PSI	Depth to Pumping Water Level [FT]/ Flow [GPM]																
			400	440	480	520	560	600	640	680	720	760	800	840	880	920	960	1000	1040
13ESN - 35STG	5	0					18.7	18.1	17.5	16.8	16.1	15.4	14.5	13.8	12.9	11.8	10.5	9.2	6.1
		20				18.7	18	17.5	16.7	15.9	15.2	14.4	13.6	12.6	11.6	10.6	9	5.4	
		30			18.8	18.3	17.7	16.9	16.2	15.5	14.6	14	13.2	12.1	10.9	9.2	7.4		
		40			18.6	17.9	17.3	16.5	15.8	15.1	14.2	13.6	12.6	11.4	10.3	8.6	5.2		
		50	18.8	18.2	17.6	16.8	16.3	15.5	14.7	13.9	13	11.8	10.6	9.6	7.6				
		60	18.9	18.5	17.8	17.1	16.5	15.8	15	14.2	13.4	12.4	11.2	9.8	8.4	4.5			
Shut-off PSI			291	274	257	239	222	205	187	170	153	135	118	101	83	66	49	32	14

# MODEL 18ESN

# SIMFLO®

## PERFORMANCE CURVES

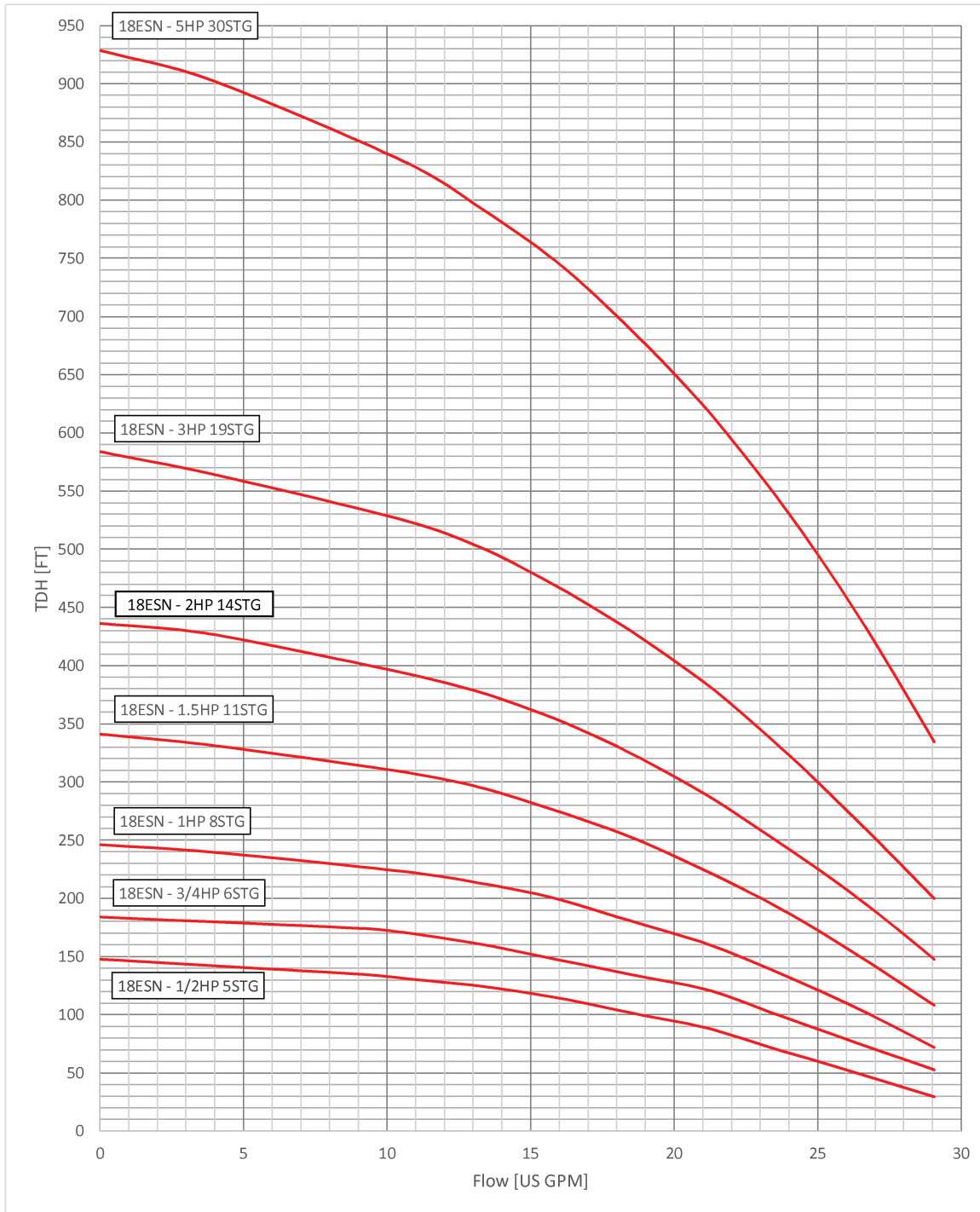

# MODEL 18ESN

# SIMFLO®

## SECTIONAL CHART

Pump Model	HP	PSI	Depth to Pumping Water Level [FT]/ Flow [GPM]						
			20	40	60	80	100	120	140
18ESN - 5STG	1/2	0			25.1	22.2	18.7	14.3	5.2
		20	24.2	21.1	17.5	12.7			
		30	20.6	16.8	11.8				
		40	16.1	10.7					
		50	9.6						
		60							
Shut-off PSI			55	47	38	29	21	12	3

Pump Model	HP	PSI	Depth to Pumping Water Level [FT]/ Flow [GPM]								
			20	40	60	80	100	120	140	160	180
18ESN - 6STG	3/4	0				26	23.6	20.8	17.6	13.5	2.9
		20			22.8	19.9	16.4				
		30	24.9	22.4	19.4	15.8	10.9				
		40	21.9	18.9	15.2	9.9					
		50	18.4	14.5	8.8						
		60	13.8	7.4							
Shut-off PSI			71	62	54	45	36	28	19	10	2

Pump Model	HP	PSI	Depth to Pumping Water Level [FT]/ Flow [GPM]											
			20	40	60	80	100	120	140	160	180	200	220	240
18ESN - 8STG	1	0						25.1	23.1	20.9	18.5	15.6	12	4
		20			26.3	24.5	22.5	20.2	17.6	14.6	10.5			
		30		26.1	24.2	22.1	19.8	17.2	14	9.7				
		40	25.8	23.9	21.8	19.5	16.8	13.5	8.8					
		50	23.6	21.4	19.1	16.3	12.9	7.7						
		60	21.1	18.7	15.8	12.2								
Shut-off PSI			98	89	81	72	63	55	46	37	29	20	11	3

Pump Model	HP	PSI	Depth to Pumping Water Level [FT]/ Flow [GPM]													
			20	40	60	80	100	120	140	160	180	200	220	240	280	320
18ESN - 11STG	1 1/2	0							25.8	24.4	22.9	21.3	19.5	15.2	7	
		20						25.4	24	22.4	20.7	18.9	16.8	14.5		
		30					25.2	23.7	22.1	20.4	18.6	16.5	14.1	10.5		
		40				25	23.5	21.9	20.2	18.3	16.1	13.6	9.5			
		50		26.2	24.7	23.2	21.6	19.9	18	15.8	13.2	8.5				
		60	25.9	24.5	23	21.4	19.6	17.6	15.4	12.7	8					
Shut-off PSI			139	130	122	113	104	96	87	78	70	61	52	44	26	9

Pump Model	HP	PSI	Depth to Pumping Water Level [FT]/ Flow [GPM]														
			80	100	120	140	160	180	200	220	240	260	280	300	320	360	400
18ESN - 14STG	2	0							25	23.9	22.7	21.4	20.1	16.5	19	15.2	9.2
		20					26.1	25	23.9	22.7	21.4	20.1	18.7	15.4	14.5	8.2	
		30				26.6	24.6	23.6	22.9	22.1	20.8	18.2	16.5	14.6	11.8		
		40			25.5	24.2	23.4	21.4	20.5	19.5	17.6	16	13.6	10	6.8		
		50		25.5	24.4	23.5	22	20.8	18.3	17.6	15.5	13.5	10				
		60	25.5	24.4	23.5	22	20.5	19.5	17.5	15.6	12.8	10	6				
Shut-off PSI			154	146	137	128	120	111	102	94	85	76	68	59	50	33	16

Pump Model	HP	PSI	Depth to Pumping Water Level [FT]/ Flow [GPM]														
			140	180	220	240	260	280	300	320	340	360	380	400	440	480	540
18ESN - 19STG	3	0					26.7	25.9	25	24.1	23.2	22.2	21.1	20.1	17.7	14.9	8
		20				25.6	24.7	23.8	22.9	21.9	20.8	19.7	18.5	17.3	14.5	10.2	
		30			25.5	24.6	23.7	22.7	21.7	20.6	19.5	18.4	17.1	15.7	12.5	7	
		40		26.2	24.5	23.5	22.6	21.5	20.5	19.4	18.2	16.9	15.5	14	9.5		
		50	26.9	25.2	23.4	22.4	21.4	20.3	19.2	18	16.7	15.3	13.7	12			
		60	26	24.2	22.2	21.2	20.1	19	17.8	16.5	15	13.5	11.6	9.2			
Shut-off PSI			192	175	158	149	140	132	123	114	106	97	88	80	62	45	19

Pump Model	HP	PSI	Depth to Pumping Water Level [FT]/ Flow [GPM]														
			320	360	400	440	480	520	560	600	640	680	720	760	800	840	880
18ESN - 19STG	5	0				26.5	25.3	24.2	22.9	21.6	20.2	18.7	17	15.2	12.8	10	6.3
		20				25.2	24	22.7	21.4	19.9	18.4	16.7	14.9	12.5	9.5		
		30			25.7	24.5	23.2	21.9	20.6	19.1	17.5	15.7	13.7	11	7.4		
		40		26.1	25	23.8	22.5	21.2	19.7	18.2	16.5	14.6	12.1	8.8			
		50		25.5	24.3	23.1	21.7	20.3	18.8	17.2	15.4	13	10.3	6.7			
		60	26	24.8	23.6	22.3	20.9	19.5	17.9	16.2	14.3	11.6	8.5				
Shut-off PSI			263	246	229	211	194	177	160	142	125	108	90	73	56	38	21

# MODEL 25ESN

# SIMFLO®

## PERFORMANCE CURVES

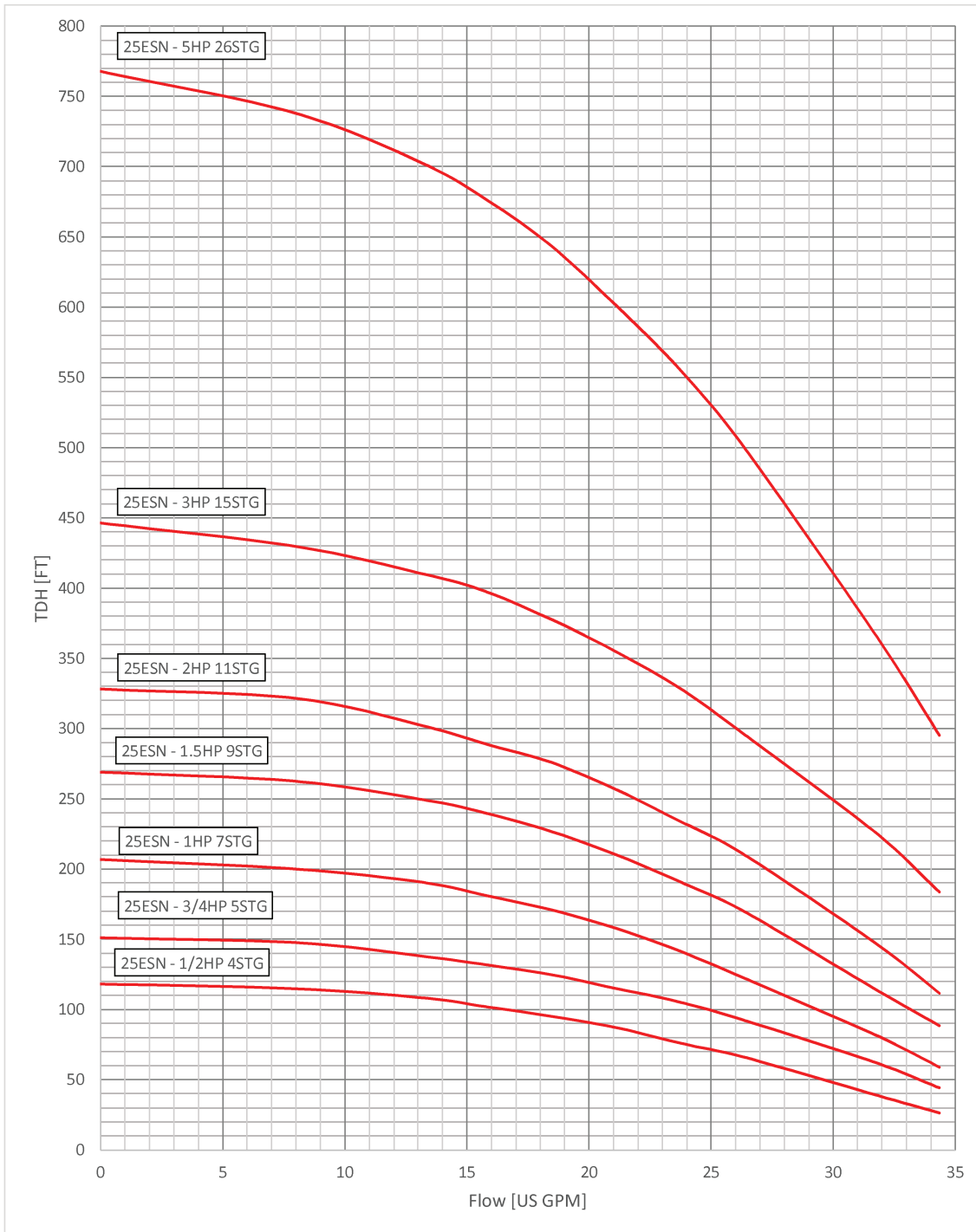



# MODEL 25ESN

# SIMFLO®

## SECTIONAL CHART

Pump Model	HP	PSI	Depth to Pumping Water Level [FT]/ Flow [GPM]				
			20	40	60	80	100
25ESN - 4STG	1/2	0		31.7	27.7	22.9	16.6
		20	26.3	21.2	13.9	11.5	
		30	20.2	12.3	13.2		
		40	10.5	14.7			
		50	16				
		60					
Shut-off PSI			42	34	25	16	8

Pump Model	HP	PSI	Depth to Pumping Water Level [FT]/ Flow [GPM]						
			20	40	60	80	100	120	140
25ESN - 5STG	3/4	0			32	28.6	24.6	19.7	12.7
		20	31	27.4	23.2	17.9	9.2		
		30	26.8	22.5	16.9				
		40	21.7	15.8					
		50	14.7						
		60							
Shut-off PSI			57	48	39	31	22	13	5

Pump Model	HP	PSI	Depth to Pumping Water Level [FT]/ Flow [GPM]									
			20	40	60	80	100	120	140	160	180	200
25ESN - 7STG	1	0				32	29.6	26.9	23.9	20.4	16.1	9.3
		20		31.2	28.8	26	22.9	19.2	14.4			
		30	30.9	28.3	25.5	22.4	18.5	13.5				
		40	27.9	25.1	21.8	17.9	12.4					
		50	24.6	21.3	17.1	11.3						
		60	20.7	16.4	10							
Shut-off PSI			81	72	64	55	46	38	29	20	12	3

Pump Model	HP	PSI	Depth to Pumping Water Level [FT]/ Flow [GPM]										
			20	40	60	80	100	120	140	160	180	200	220
25ESN - 9STG	1 1/2	0				31.4	29.5	27.4	25	22.4	19.4	15.7	9.8
		20			31.4	29.5	27.4	25	22.4	19.4			
		30			30.5	28.4	26.2	23.8	21				
		40		31.4	29.5	27.4	25	22.4					
		50		30.5	28.4	26.2	23.8						
		60	31.4	29.5	27.4	25							
Shut-off PSI			108	99	90	82	73	65	56	47	39	30	21

Pump Model	HP	PSI	Depth to Pumping Water Level [FT]/ Flow [GPM]												
			80	100	120	140	160	180	200	220	240	260	280	300	320
25ESN - 11STG	2	0					30.7	29	27.1	25.1	22.9	20.5	17.6	14.1	8.8
		20				30.7	29	27.1	25.1	22.9	20.5	17.6	14.1	8.8	
		30			31.5	29.8	28.1	26.1	24.1	21.8	19.1	16	11.9		
		40			30.7	29	27.1	25.1	22.9	20.5	17.6	14.1	8.8		
		50		31.5	29.8	28.1	26.1	24.1	21.8	19.1	16	11.9			
		60	32.3	30.7	29	27.1	25.1	22.9	20.5	17.6	14.1				
Shut-off PSI			107	99	90	81	73	64	55	47	38	29	21	12	3

Pump Model	HP	PSI	Depth to Pumping Water Level [FT]/ Flow [GPM]															
			80	100	120	140	160	180	200	220	240	260	280	300	320	340	380	420
25ESN - 15STG	3	0							33.4	32.1	30.7	29.3	27.7	26.1	24.3	22.4	18	11
		20					33	31.7	30.3	28.8	27.2	25.6	23.8	21.8	19.6	17.2	8.8	
		30				32.8	31.5	30	28.6	27	25.3	23.5	21.5	19.3	16.8	13.8		
		40			32.6	31.2	29.8	28.3	26.7	25	23.2	21.2	18.9	16.3	12.5			
		50		32.4	31	29.6	28.1	26.5	24.7	22.9	20.8	18.5	15.9	12				
		60	32.2	30.8	29.4	27.8	26.2	24.5	22.6	20.5	18.2	15.4	11.3					
Shut-off PSI			159	150	141	133	124	115	107	98	89	81	72	63	55	46	29	11

Pump Model	HP	PSI	Depth to Pumping Water Level [FT]/ Flow [GPM]															
			200	240	280	320	360	400	440	480	520	540	560	580	620	660	700	740
25ESN - 26STG	5	0				33.5	32.1	30.5	28.9	27.2	25.3	24.3	23.3	22.2	19.8	17.1	13.5	7.5
		20			33.3	31.8	30.3	28.6	26.9	25	22.9	21.8	20.7	19.4	16.6	13.6	5.7	
		30			32.5	31	29.3	27.6	25.8	23.8	21.7	20.5	19.2	17.9	14.9	9.8		
		40		33.1	31.6	30	28.4	26.6	24.7	22.6	20.3	19	17.6	16.1	11.8			
		50		32.2	30.7	29.1	27.4	25.5	23.5	21.3	18.8	17.4	15.9	13.5	8.5			
		60	32.9	31.4	29.8	28.1	26.3	24.4	22.3	19.9	17.2	15.8	13.6	11.2				
Shut-off PSI			246	228	211	194	176	159	142	125	107	99	90	81	64	47	29	12

# MODEL 35ESN

# SIMFLO®

## PERFORMANCE CURVES

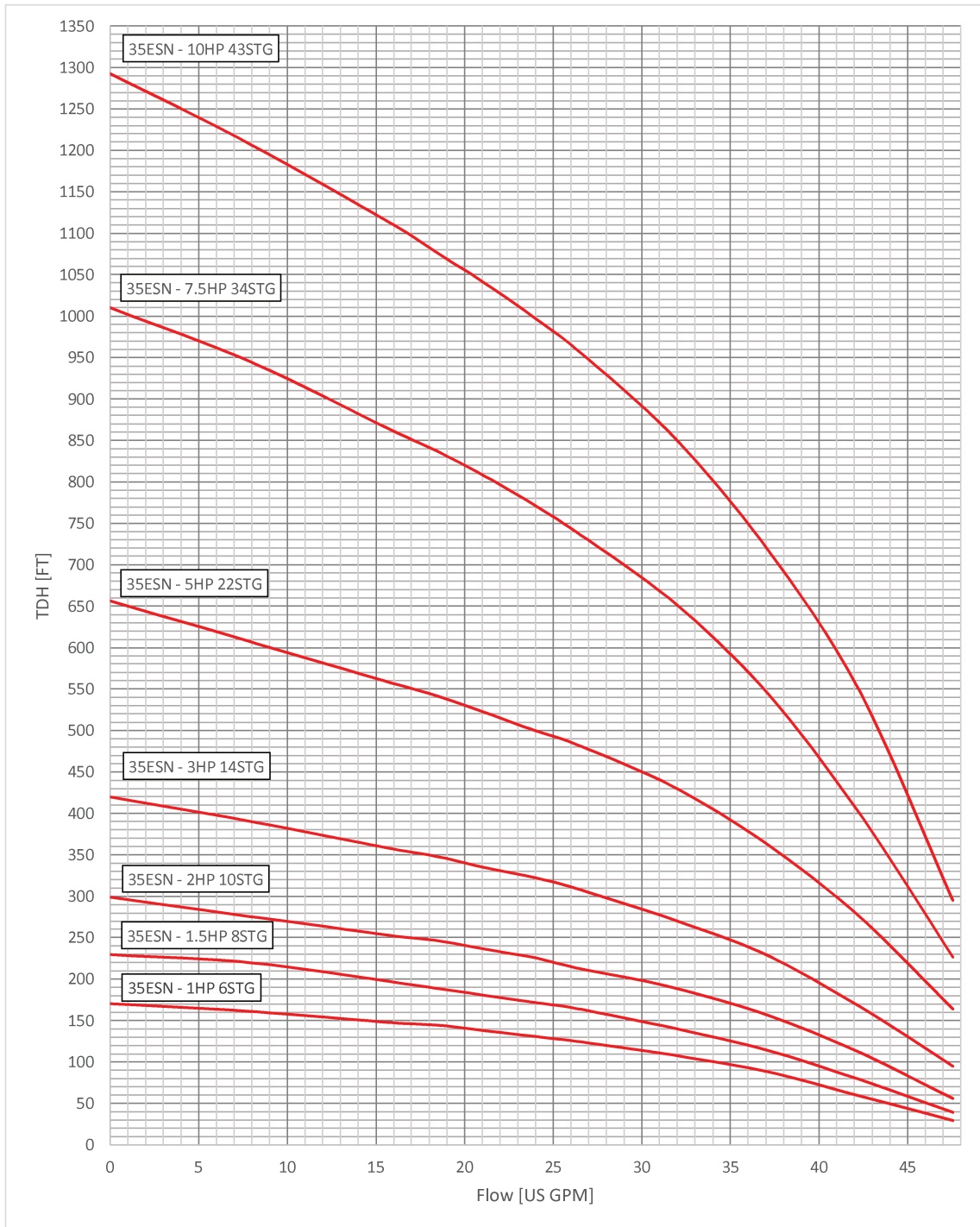

# MODEL 35ESN



## SECTIONAL CHART

Pump Model	HP	PSI	Depth to Pumping Water Level [FT]/ Flow [GPM]									
			20	40	60	80	100	120	140	160		
35ESN - 6STG	1	0		45.5	42	38.5	34	28	20	8		
		20	41	37.5	29.5	26	17					
		30	37	32	25	15						
		40	30	24	12							
		50	22	11								
		60	9.9									
Shut-off PSI			65	57	48	39	31	22	13	5		

Pump Model	HP	PSI	Depth to Pumping Water Level [FT]/ Flow [GPM]										
			20	40	60	80	100	120	140	160	180	200	220
35ESN - 8STG	1 1/2	0			45.1	42	38.7	35.2	31.3	27	21.9	15	6.9
		20	44.2	41	37.7	34	30	25.5	20.2	13.5			
		30	40.5	37.1	33.4	29.4	24.7	19.3	12.2				
		40	36.6	32.8	28.7	23.9	18.3	10.8					
		50	32.2	28	23.1	17.3	9.3						
		60	28.2	22.3	16.3	7.7							
Shut-off PSI			91	82	73	65	56	47	39	30	21	13	4

Pump Model	HP	PSI	Depth to Pumping Water Level [FT]/ Flow [GPM]													
			20	40	60	80	100	120	140	160	180	200	220	240	260	280
35ESN - 10STG	2	0					43.4	41.2	39	36.3	33.5	29.5	25.1	20.3	12.5	6.5
		20			42.8	40.8	38.2	36	32.5	28	24	19	6.5	4.5		
		30			40.2	38.5	35.8	32.2	28	23.1	18	10.5	4.5			
		40		40	37.4	36	31.4	26.4	21.6	15.6	8					
		50		37.5	34.2	34.2	26.5	21.5	18	6.5						
		60	37.2	34.2	30.2	25.6	20.5	14.2	7.5							
Shut-off PSI			121	112	103	95	86	77	69	60	51	43	34	25	17	8

Pump Model	HP	PSI	Depth to Pumping Water Level [FT]/ Flow [GPM]														
			20	40	60	80	100	120	140	160	180	200	220	240	280	320	360
35ESN - 14STG	3	0							44.6	42.8	40.9	38.9	36.8	34.6	29.8	24.2	15
		20					44	42.2	40.2	38.2	36.1	33.9	31.5	29	23.2	11.5	
		30				43.7	41.9	39.9	37.9	35.8	33.5	31.1	28.6	25.8	18	11	
		40			43.5	41.6	39.6	37.6	35.4	33.2	30.7	28.1	25.3	22	12		
		50		43.2	41.3	39.3	37.3	35.1	32.8	30.3	27.7	24.9	21	16	6.5		
		60	42.9	41	39	36.9	34.7	32.4	30	27.3	24.4	20	15.5	11			
Shut-off PSI			173	164	156	147	139	130	121	113	104	95	87	78	61	43	26

Pump Model	HP	PSI	Depth to Pumping Water Level [FT]/ Flow [GPM]																
			100	140	180	220	260	300	320	340	360	380	400	420	460	500	540	580	620
35ESN - 22STG	5	0				45.4	42.9	41	39.6	38.5	36.1	35.8	34.5	32.8	28	24.2	18.5	12	6
		20			44.8	42.5	40.5	38.2	35.6	35.2	33.8	30.9	29.2	27.4	23.5	17.5	11.5		
		30			43.6	41	38.3	35.4	33.9	32.3	30.7	29	27.1	25.2	21	14	7.5		
		40		44.6	42.1	39.5	36.7	33.7	32.1	30.4	28.7	26.9	24.9	22.9	17	10			
		50	45.6	43.2	40.6	37.9	35	31.8	30.1	28.4	26.6	24.6	22.5	19	13	6.5			
		60	44.2	41.7	39	36.2	33.2	29.9	28.1	26.3	24.3	22.2	19	15.5	9				
Shut-off PSI			241	223	206	189	171	154	146	137	128	120	111	102	85	68	50	33	16

Pump Model	HP	PSI	Depth to Pumping Water Level [FT]/ Flow [GPM]																			
			140	180	220	260	300	340	380	420	460	480	520	560	600	640	680	720	760	800	840	880
35ESN - 34STG	7 1/2	0					45.5	44	42.9	41.3	40.2	38.8	37.2	35.5	33.6	31.5	29	23.5	20.8	16	12.3	8.5
		20				45.2	44.1	42.8	39.4	38.1	36.7	37.8	36.2	34.6	31.1	28.8	25.8	22.9	19.5	11.5		
		30				44.6	43.2	41.1	38.4	37.8	37.4	37	35.2	33.2	29.9	27.5	24.5	21.2	17.5			
		40			44	43.7	42.8	40.8	37.4	36.5	36	35.5	33.8	31.9	28.6	26.1	22	18.8	15			
		50			44.2	43	41.6	40.5	36.4	35	34.5	33	32.6	30.6	27.1	24.7	20.5	16.5				
		60	44.6	43.8	42.3	41	39.2	35.4	33.9	32.3	31.1	31.8	29.2	25.8	23.2	18.3	14.5					
Shut-off PSI			392	377	360	342	325	308	290	273	256	238	230	212	195	178	160	143	126	108	91	74

Pump Model	HP	PSI	Depth to Pumping Water Level [FT]/ Flow [GPM]																				
			200	250	300	350	400	450	500	550	600	650	700	750	800	850	900	950	1000	1050	1100	1150	1200
35ESN - 43STG	10	0						44.5	43	41.5	39.9	38.2	36.5	34.7	32.8	30.8	28.7	26.5	24	20.5	16.7	12.5	8.5
		20					44.6	43.1	41.6	40	38.3	36.6	34.8	33	31	28.9	26.6	24.2	20.5	17	13		
		30				45	43.9	42.4	40.8	39.2	37.6	35.8	34	32.1	30	27.9	25.5	22.5	19	15	11		
		40				44.5	43.2	41.7	40.1	38.5	36.8	35	33.1	31.1	29	26.8	24.4	21	17	13	9		
		50			45.1	44	42.5	41	39.4	37.7	35.9	34.1	32.2	30.2	28	25.7	22.5	19	15.5	11.5	7		
		60			44.8	43.3	41.8	40.2	38.6	36.9	35.1	33.2	31.3	29.2	27	24.6	21	17.5	13.5	9			
Shut-off PSI			473	451	430	408	386	365	343	321	300	278	257	235	213	192	170	148	127	105	83	62	40

# MODEL 55ESN

# SIMFLO®

## PERFORMANCE CURVES

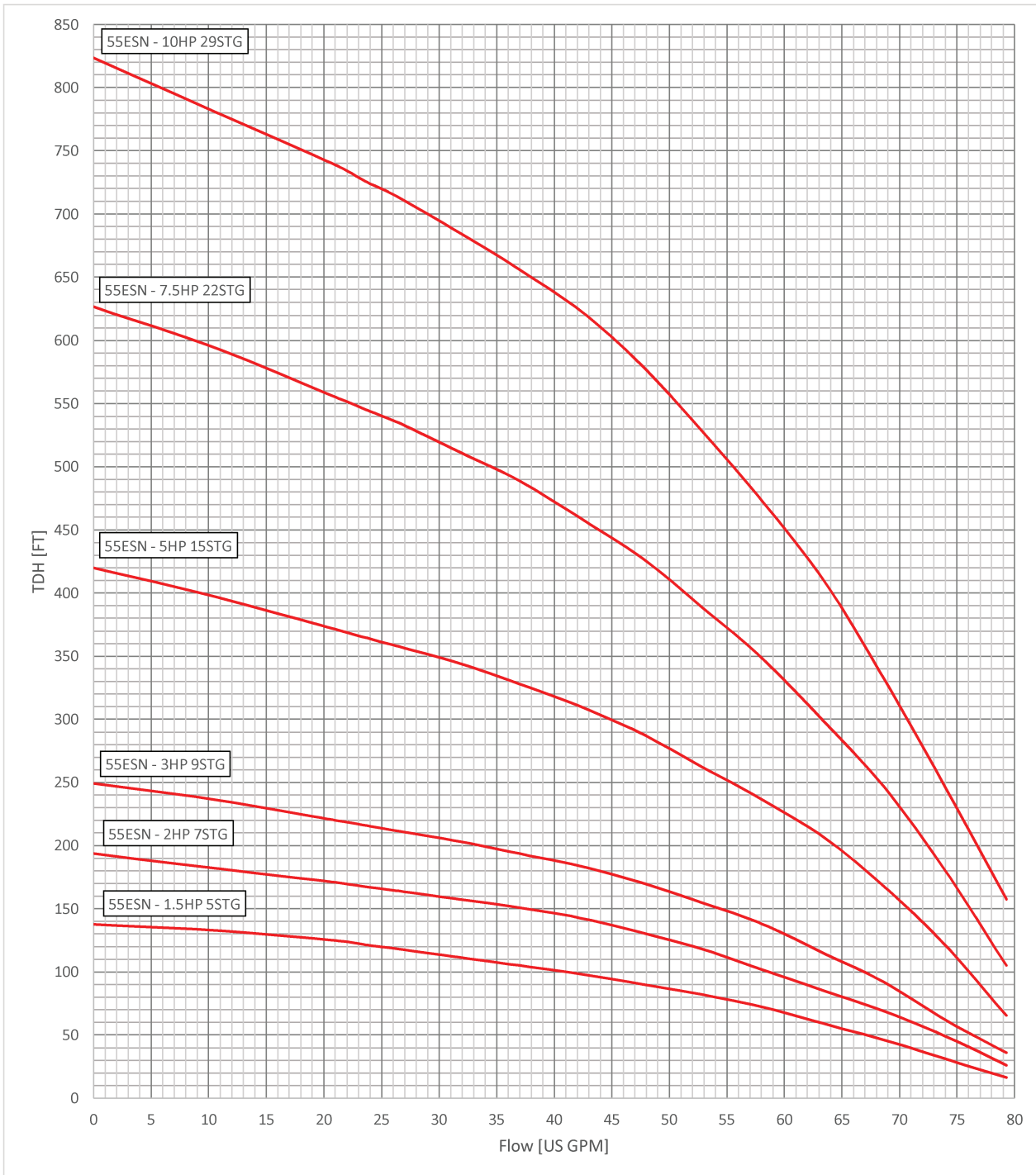

# MODEL 55ESN

# SIMFLO®

## SECTIONAL CHART

Pump Model	HP	PSI	Depth to Pumping Water Level [FT]/ Flow [GPM]						
			20	40	60	80	100	120	130
55ESN - 5STG	1 1/2	0		70	63	54.8	41.3	25	14.2
		20	61	50.8	36	20			
		30	47.8	34.3	16.9				
		40	30.4	10.2					
		50	6.2						
		60							
Shut-off PSI			51	42	34	25	16	8	3

Pump Model	HP	PSI	Depth to Pumping Water Level [FT]/ Flow [GPM]								
			20	40	60	80	100	120	140	160	180
55ESN - 7STG	2	0			71	64.9	58.2	50.8	42.1	30	13
		20	69.2	62.9	57	50	39.1	25			
		30	61.9	54.9	49	38.5	23				
		40	53.7	47	35.8	19					
		50	46	34.1	18						
		60	32.2								
Shut-off PSI			75	66	58	49	41	32	23	15	6

Pump Model	HP	PSI	Depth to Pumping Water Level [FT]/ Flow [GPM]										
			20	40	60	80	100	120	140	160	180	200	220
55ESN - 9STG	3	0			75.4	70.9	66.2	61.2	55.7	49.7	42.8	34.8	21
		20		69.5	64.7	48.5	53.5	48.5	39	25	17		
		30	68.8	65	60.2	55	46.6	37.5	39.5	14			
		40	63.1	58.8	53	47	37.5	23.6					
		50	59	52.9	45.3	36.7	22						
		60	52	43.3	35.4	23							
Shut-off PSI			99	91	82	73	65	56	47	39	30	21	13

Pump Model	HP	PSI	Depth to Pumping Water Level [FT]/ Flow [GPM]																	
			40	60	80	100	120	140	160	180	200	220	240	260	280	320	360	400		
55ESN - 15STG	5	0								68.8	66.8	64.7	61	56	53.3	48.4	39.5	25.5	9.4	
		20					69	66	63	59.4	56.9	52.7	48	48	38	23				
		30				67.4	66	63.5	59.5	55.3	52.9	48	42.1	37	30.5	14				
		40		69.8	66.9	65	62	58.5	54.5	50.9	45.5	41	35.5	28	19					
		50	69.4	66.5	63.4	62	58	54	49.3	46.2	41	35	27	19	11					
		60	66	62.9	59.6	58	54	50	45.5	40.9	31	26	19	10						
Shut-off PSI			164	156	147	139	130	121	113	104	95	87	78	69	61	43	26	9		

Pump Model	HP	PSI	Depth to Pumping Water Level [FT]/ Flow [GPM]																
			80	120	160	200	240	280	320	340	360	400	440	480	520	560	600		
55ESN - 22STG	7 1/2	0				72.3	68.5	65.4	61.1	59	56.4	54	51.4	47.7	46.2	38.7	29.8	19.5	8.5
		20			71.8	68.5	63.7	60.4	55.7	53.4	50.6	47.8	44.5	41	38.9	29	19.2		
		30			70.5	66.5	61.2	57.7	52.8	50.4	47.4	44.5	41.4	37.1	33	23	11.7		
		40		71.2	68	63.1	59.5	54.9	49.7	46.5	44	41.5	35	31.5	26.5	16.5			
		50	73	69.5	65.5	61.5	57	52	46.5	43.8	39.5	35	31	26	21	9			
		60	71.5	67.5	63.5	60.5	54.5	49.5	42.5	39.5	35	30.5	26	19.5	15.5				
Shut-off PSI			237	219	202	185	167	150	133	124	115	107	98	89	81	63	46	29	12

Pump Model	HP	PSI	Depth to Pumping Water Level [FT]/ Flow [GPM]																
			160	200	240	280	320	360	400	440	480	520	560	600	640	680	720	760	800
55ESN - 29STG	10	0					69.3	66.2	64.1	61	57.3	53.5	49.5	45.2	39.4	32.9	25	16.8	6
		20				68.8	66.5	64	60.2	56.9	52.9	48.9	44.5	39.6	32	24	15		
		30			70	67.1	65	61.7	58.2	54.8	50.6	46.4	41.7	34	27.5	18.5	8.8		
		40			68.3	66	63	60	56.1	52.5	48.2	43.7	38	29	22.5	12.5			
		50		69.6	67.2	64	61.5	58	54	49.2	45.7	40.9	34	26	17	7			
		60	70.8	67.9	66	63	58.2	56	51.7	47.8	43	37.9	29	22	11.5				
Shut-off PSI			287	270	253	235	218	201	183	166	149	131	114	97	79	62	45	27	10

# MODEL 80ESN

# SIMFLO®

## PERFORMANCE CURVES

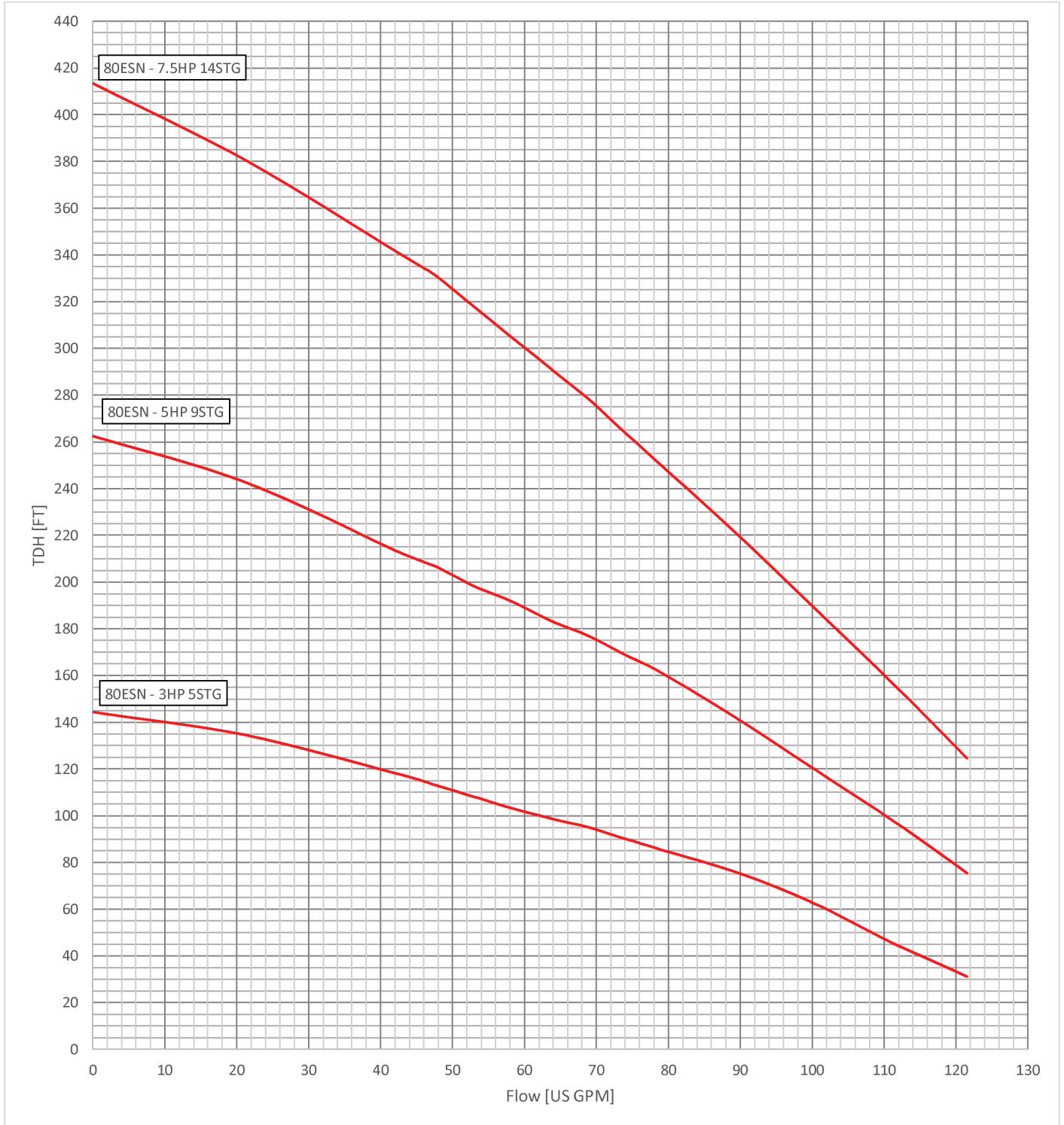

## SECTIONAL CHART

Pump Model	HP	PSI	Depth to Pumping Water Level [FT]/ Flow [GPM]						
			20	40	60	80	100	120	
80ESN - 5STG	3	0		116.4	100.8	83.4	63.7	40.1	
		20	95.6	79	56.9	34			
		30	74.6	52	34				
		40	49.7	26					
		50							
		60							
Shut-off PSI			54	45	37	28	19	11	

Pump Model	HP	PSI	Depth to Pumping Water Level [FT]/ Flow [GPM]										
			20	40	60	80	100	120	140	160	180	200	220
80ESN - 9STG	5	0					110.4	100.4	90.5	79.5	66.3	53.1	38.6
		20			107.4	97.2	87.8	75.8	62.4	48.8			
		30		105.8	95.5	85	74	60.4	46.6				
		40	104.3	93.9	85	73	52	44.3					
		50	92.2	82	70	56.2	41						
		60	79.3	67.2	53	39.6							
Shut-off PSI			105	96	88	79	70	62	53	44	36	27	18

Pump Model	HP	PSI	Depth to Pumping Water Level [FT]/ Flow [GPM]														
			20	40	60	80	100	120	140	160	180	200	220	240	280	320	360
80ESN - 14STG	7 1/2	0							116.3	110.1	103.8	97.2	90.4	82.3	68.1	51.5	32.4
		20					115	108.2	101.7	94.2	87.8	81.5	73.4	67	51	31	
		30				113.5	107.2	100.8	93	86.5	80	73	65	59.5	41.5	20	
		40			112.5	106.2	96.5	93	86.1	78.8	71.2	61.7	55.5	47.5	26		
		50		111.5	105.2	98.7	92	84.2	77.7	70	62	56	46	35			
		60	110.6	104.2	97.7	90.9	83.9	76.5	68.8	60.7	52.1	47.6					
Shut-off PSI			170	162	153	144	136	127	118	110	101	92	84	75	58	40	23

## GENERAL DATA

### ESS Model - General Data

Model	HP	Stages	Order Number	Length (IN)	Discharge	Weight (LBS)
5ESS	1/2	13	△	17.3	1-1/4" NPT	7.9
	3/4	18	△	21.5	1-1/4" NPT	9.7
	1	22	△	24.8	1-1/4" NPT	11.2
	1 1/2	26	△	28.1	1-1/4" NPT	12.8
	2	31	△	33.1	1-1/4" NPT	19.4
10ESS	1/2	9	△	13	1-1/4" NPT	7.3
	3/4	12	ESS.04O14.010.15.10D	15.2	1-1/4" NPT	8.4
	1	15	△	17.9	1-1/4" NPT	9.9
	1 1/2	21	△	21.5	1-1/4" NPT	11.9
	2	27	△	26.6	1-1/4" NPT	14.6
	3	34	△	33.8	1-1/4" NPT	20.5
18ESS	1/2	7	△	10.7	1-1/4" NPT	5.1
	3/4	10	△	12.4	1-1/4" NPT	5.7
	1	12	△	14	1-1/4" NPT	6.6
	1 1/2	17	△	17.3	1-1/4" NPT	8.4
	2	20	△	20.6	1-1/4" NPT	9.9
	3	27	△	25.6	1-1/4" NPT	12.6
	5	42	△	37.2	1-1/4" NPT	23.1
25ESS	1/2	4	△	9.9	1-1/2" NPT	4.4
	3/4	5	△	10.7	1-1/2" NPT	4.9
	1	7	△	12.4	1-1/2" NPT	5.7
	1 1/2	9	△	14	1-1/2" NPT	6.6
	2	11	△	15.7	1-1/2" NPT	7.5
	3	15	△	19	1-1/2" NPT	9
40ESS	5	26	ESS.04O18.025.26.50D	28.1	1-1/2" NPT	13.7
	2	5	△	19.5	2" NPT	11.7
	5	6	△	32.8	2" NPT	20.5
	7 1/2	8	ESS.04O20.040.25.75D	49.3	2" NPT	31.5

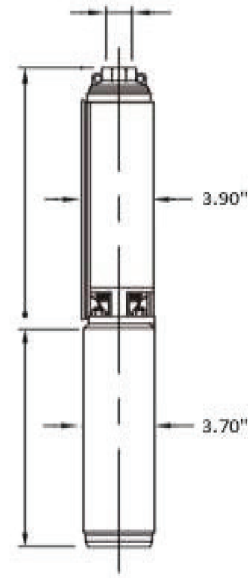

\*Contact Factory for product availability outside of listings  
 Rotation is Counterclockwise when observed from pump discharge end

#### Agency Listing



Drinking Water NSF/ANSI 61  
 NSF/ANSI 372

#### Features:

- Stainless steel construction designed and built for years of trouble free operation.
- Designed and built to operate in difficult conditions.
- All metal parts are made of 304SS steel.
- Heavy duty stainless steel discharge with built-in check valve to help prevent back flow and alleviate water hammer.
- High quality shaft bearing provide low friction and high wear resistance.
- Stop ring prevents to the pump during transport and is designed as a thrust bearing, limiting axial moments of the pump shaft.
- Stainless steel strainer to restrict the entry of sand and other extraneous material.
- Sand Content: Max. 50g/m<sup>3</sup>



## GENERAL DATA

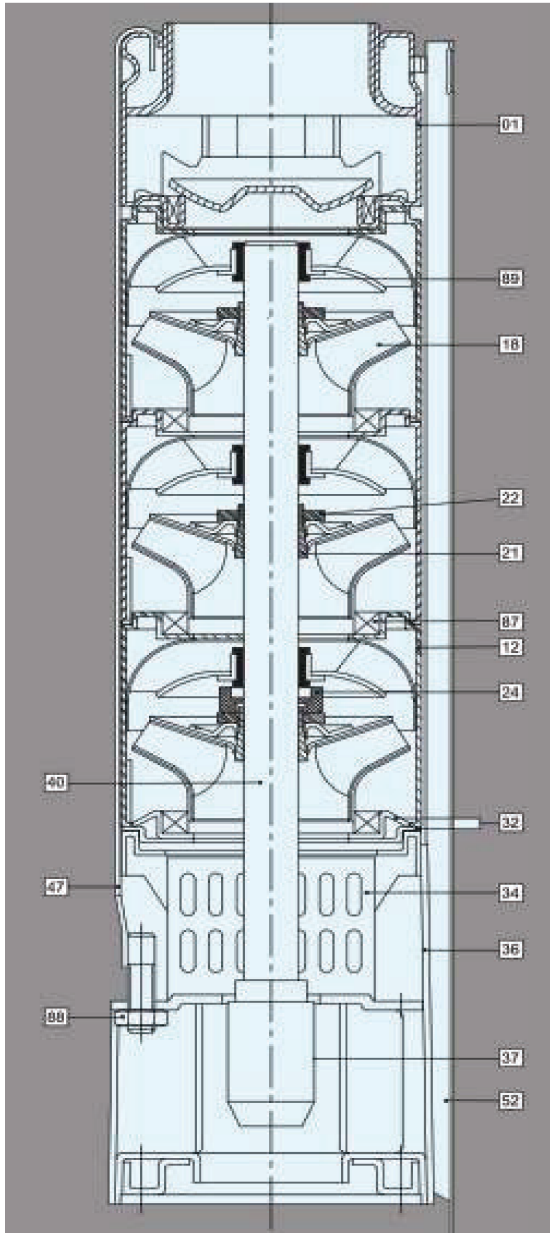

Pos.	Part Name	Materials
1	Discharge	304 SS
12	Diffuser	304 SS
18	Impeller	304 SS
21	Split Cone	304 SS
22	Split Cone Nut	304 SS
24	Stop Ring	Carbon+Graphite+PTFR
32	Neck Ring Retainer	304 SS
34	Strainer	304 SS
36	Suction Interconnector	304 SS
37	Coupling	304 SS
40	Pumpshaft	304 SS
47	Strap	304 SS
52	Cable Guard	304 SS
87	Neck Ring Retainer	304 SS + NBR
88	Nut	304 SS
89	Bearing	NBR

## PERFORMANCE CURVES

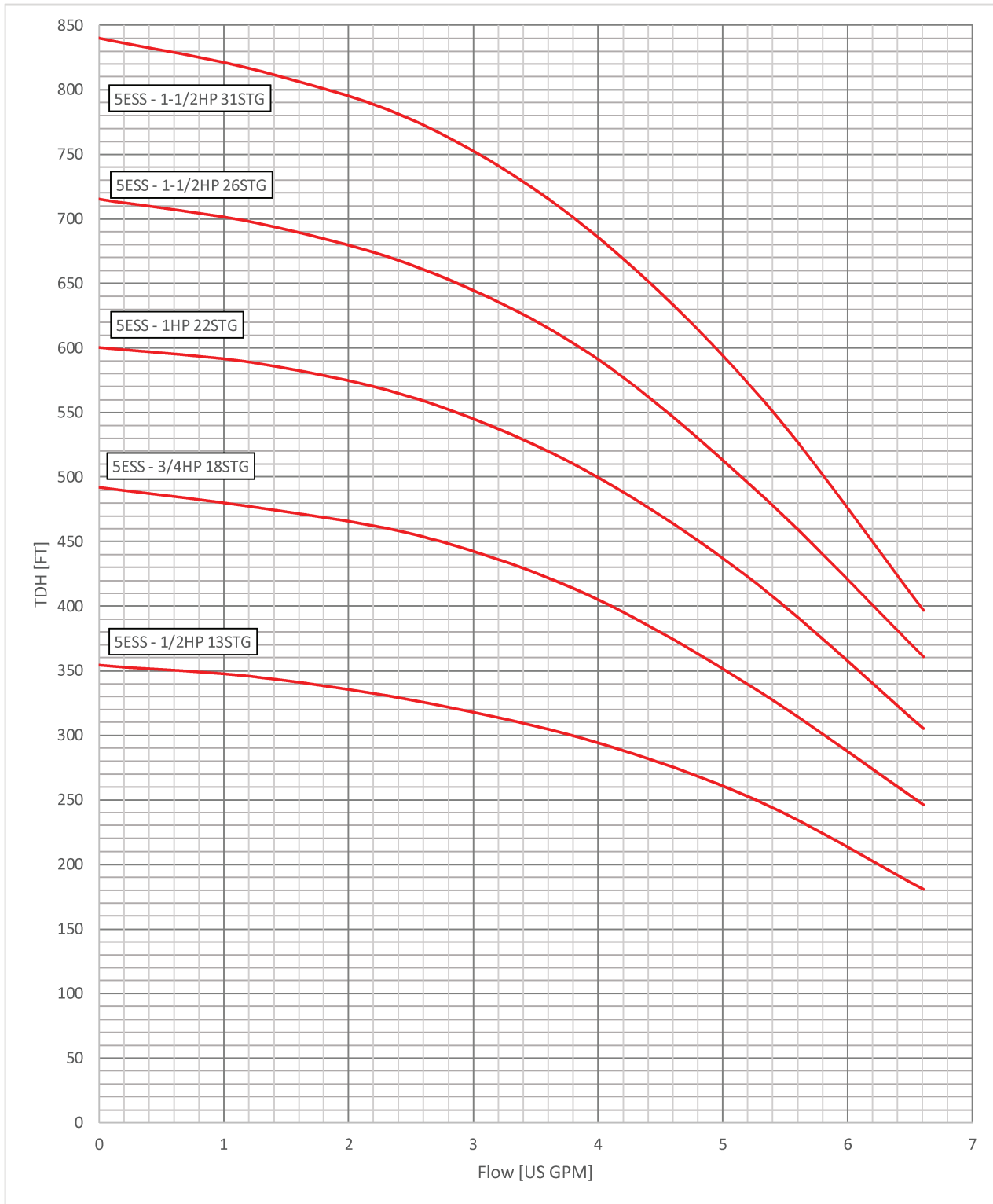

## SECTIONAL CHART

Pump Model	HP	PSI	Depth to Pumping Water Level [FT]/ Flow [GPM]												
			80	100	120	140	160	180	200	220	240	260	280	300	320
5ESS - 13STG	1/2	0							6.2	5.9	5.5	4.8	4.4	3.8	2.9
		20					6.1	5.8	5.3	4.6	4.3	3.5	2.5	1.2	
		30				6.1	5.7	5.3	4.6	4.3	3.6	2.4			
		40			6	5.6	5.1	4.5	3.9	3.2	2.1				
		50		6	5.6	5.1	4.5	3.9	3.1	2					
		60	6	5.5	5.1	4.5	3.8	3	1.9						
Shut-off PSI			119	110	101	93	84	75	67	58	49	41	32	24	15

Pump Model	HP	PSI	Depth to Pumping Water Level [FT]/ Flow [GPM]														
			140	160	180	200	220	240	260	280	300	320	340	360	380	420	460
5ESS - 18STG	3/4	0							6.4	6.1	5.8	5.5	5.2	4.9	4.5	3.6	2.3
		20					6.3	6.1	5.7	5.5	5.1	4.7	4.4	4	3.5	2.1	
		30				6.3	6.1	5.7	5.5	5.1	4.6	4.3	3.9	3.5	2.7		
		40			6.2	5.9	5.7	5.4	4.9	4.6	4.2	3.8	3.4	2.6			
		50		6.2	5.9	5.6	5.3	4.9	4.6	4.2	3.8	3.2	2.1				
		60	6.2	5.9	5.6	5.4	4.9	4.5	4.1	3.7	3.1	1.7					
Shut-off PSI			152	144	135	126	118	109	100	92	83	75	66	57	49	31	14

Pump Model	HP	PSI	Depth to Pumping Water Level [FT]/ Flow [GPM]														
			200	240	280	320	360	400	420	440	460	480	500	520	540	560	580
5ESS - 22STG	1	0					6	5.5	5.2	4.9	4.6	4.3	4	3.6	3.1	2.6	1.6
		20			6.4	5.9	5.4	4.8	4.5	4.2	3.8	3.4	3	2.4	1.4		
		30			6.1	5.6	5.1	4.5	4.1	3.8	3.4	2.9	2.3	1.4			
		40		6.3	5.8	5.3	4.8	4.1	3.7	3.3	2.8	2.2					
		50		6.1	5.6	5	4.4	3.7	3.2	2.7	2.1						
		60	6.2	5.8	5.2	4.7	4	3.2	2.6	1.9							
Shut-off PSI			173	156	139	121	104	87	78	69	61	52	43	35	26	17	9

Pump Model	HP	PSI	Depth to Pumping Water Level [FT]/ Flow [GPM]														
			260	300	340	380	420	460	500	540	560	580	600	620	640	660	680
5ESS - 26STG	1 1/2	0				6.4	6	5.6	5.2	4.7	4.4	4.1	3.8	3.4	3.1	2.6	2
		20			6.4	6	5.4	5.1	4.6	4	3.7	3.3	2.9	2.5	1.8		
		30		6.5	6.1	5.7	5.3	4.8	4.3	3.6	3.3	2.9	2.4	1.6			
		40		6.3	5.9	5.5	5	4.5	3.9	3.2	2.6	2.3	1.2				
		50	6.5	6.1	5.7	5.2	4.7	4.2	3.6	2.5	2.2	1.3					
		60	6.3	5.9	5.4	4.9	4.4	3.8	3.1	2.1	1.2						
Shut-off PSI			197	180	162	145	128	110	93	76	67	59	50	41	33	24	15

Pump Model	HP	PSI	Depth to Pumping Water Level [FT]/ Flow [GPM]														
			300	340	380	420	460	500	540	560	580	620	660	700	740	780	820
5ESS - 31STG	1 1/2	0				6.5	6.1	5.8	5.5	5.3	5.1	4.7	4.3	3.8	3.2	2.5	1
		20			6.4	6.1	5.8	5.4	5	4.8	4.6	4.2	3.7	3.1	2.3		
		30		6.5	6.2	5.9	5.6	5.2	4.8	4.6	4.4	3.9	3.4	2.5	1.5		
		40		6.4	6.1	5.7	5.4	5	4.6	4.4	4.1	3.6	3	2			
		50	6.5	6.2	5.9	5.5	5.1	4.7	4.3	4.1	3.8	3.3	2.6	1.2			
		60	6.3	6	5.7	5.3	4.9	4.5	4	3.8	3.5	2.9	2				
Shut-off PSI			234	216	199	182	164	147	130	121	113	95	78	61	43	26	9

# MODEL 10ESS

# SIMFLO®

## PERFORMANCE CURVES

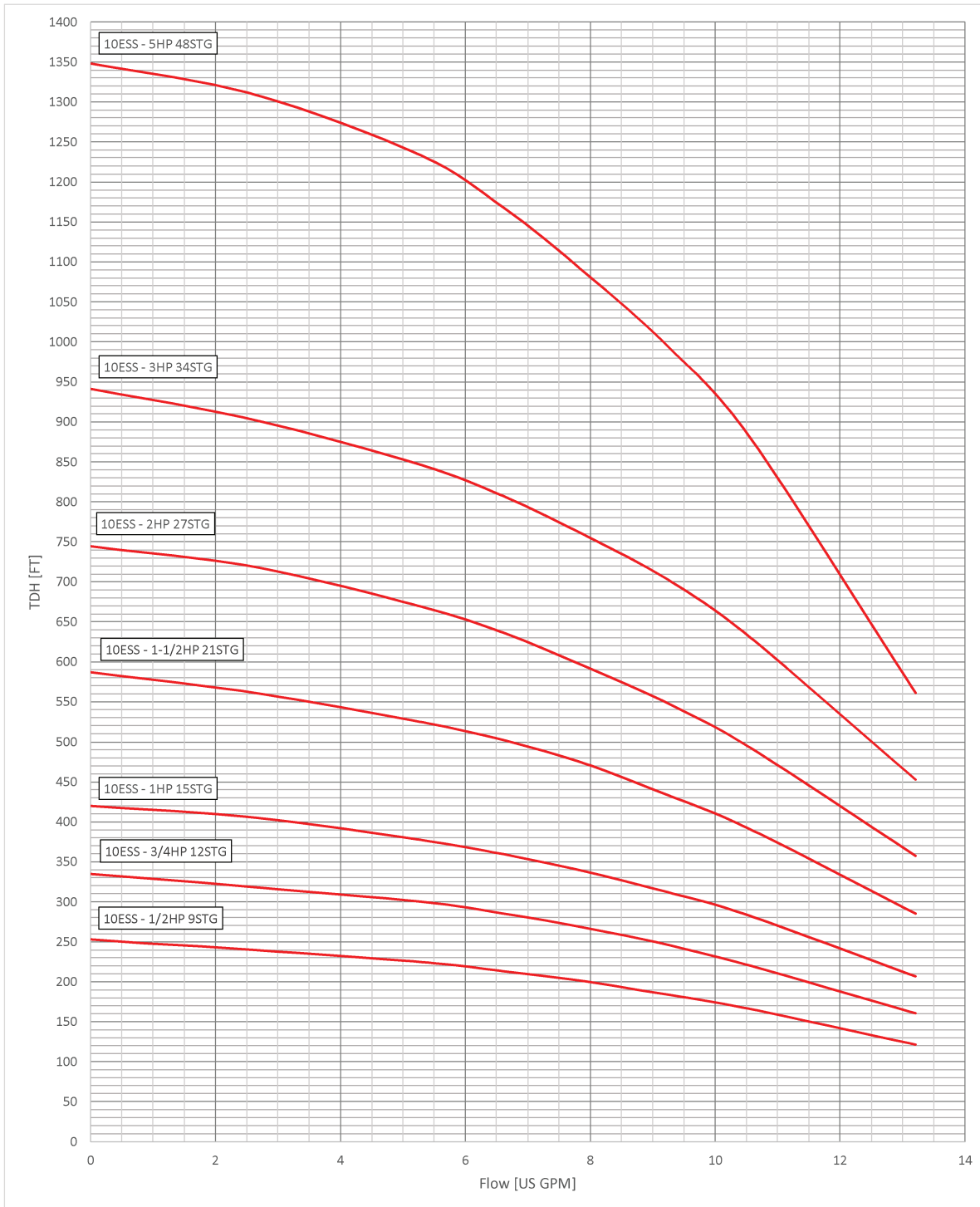

# MODEL 10ESS

# SIMFLO®

## SECTIONAL CHART

Pump Model	HP	PSI	Depth to Pumping Water Level [FT]/ Flow [GPM]															
			0	20	40	60	80	100	110	120	130	140	150	170	200	240		
10ESS - 9STG	1/2	0										12.8	12.2	11.6	10.2	7.9	2.5	
		20						11.8	11.2	10	9.8	9	8.2	6.3	1.5			
		30				12.8	11.6	9.9	9.8	9	8.2	7.2	6.2	3.2				
		40			12.6	11.6	10	8.5	7.6	6.5	5.6	3.6	2					
		50		12.4	11.2	9.8	8.2	6.4	5.2	3.6								
		60	12.3	11	9.6	8.2	6.2	3.3										
Shut-off PSI			109	101	92	83	75	66	62	57	53	49	44	36	23	5		
Pump Model	HP	PSI	Depth to Pumping Water Level [FT]/ Flow [GPM]															
			40	60	80	100	120	140	160	180	200	220	240	260	280	320		
10ESS - 12STG	3/4	0									12.4	11.5	10.6	9.5	8.3	7	2.4	
		20						12.2	11.2	10.3	9.2	7.9	6.5	4.7				
		30					12	11.1	10.1	9	8	6.3	4.2					
		40			12.4	11.6	10.9	9.9	8.8	7.5	5.6	3.1						
		50		12.6	11.7	10.8	9.8	8.6	7.3	5.7	3							
		60	12.5	11.6	10.6	9.6	8.7	7.3	5.6	3.2								
Shut-off PSI			128	119	110	102	93	84	76	67	58	50	41	32	24	6		
Pump Model	HP	PSI	Depth to Pumping Water Level [FT]/ Flow [GPM]															
			100	120	140	160	180	200	220	240	260	280	300	340	360	400		
10ESS - 15STG	1	0									12.1	11.4	10.6	9.7	7.8	6.6	3.4	
		20					12.6	11.9	11.1	10.5	9.4	8.5	7.4	4.5	2.5			
		30				12.5	11.8	11	10.5	9.5	8.5	7.5	6	2.3				
		40			12.4	11.7	10.9	10.1	8.6	8.2	7.1	5.5	3.6					
		50		12.3	11.5	10.8	9.9	9	8.1	6.7	5.6	3.4						
		60	12.2	11.4	10.6	9.8	8.9	8	6.7	5.3	3.5							
Shut-off PSI			139	130	121	113	104	95	87	78	69	61	52	35	26	9		
Pump Model	HP	PSI	Depth to Pumping Water Level [FT]/ Flow [GPM]															
			180	200	220	240	260	280	300	320	380	420	460	500	540	560		
10ESS - 21STG	1 1/2	0								12.9	12.4	10.8	9.6	8.3	6.7	4.6	3.2	
		20					12.8	12.2	11.8	11.2	9.4	8.2	6.4	3.8				
		30				12.7	12.2	11.7	11.1	10.6	8.9	7.2	4.9	2				
		40			12.6	12.1	11.6	11	10.5	9.9	7.8	5.9	3.3					
		50		12.5	12	11.5	11	10.4	9.8	9.1	6.9	4.5						
		60	12.5	12	11.2	10.9	10.3	9.7	9	8.5	5.8	3.1						
Shut-off PSI			176	168	159	150	142	133	124	116	90	72	55	38	20	12		
Pump Model	HP	PSI	Depth to Pumping Water Level [FT]/ Flow [GPM]															
			260	280	300	320	360	400	440	480	520	560	600	640	680	720		
10ESS - 27STG	2	0						12.4	11.7	10.8	9.9	8.9	7.8	6.5	4.9	2.4		
		20					12.3	11.5	10.7	9.7	8.7	7.6	6.2	4.6	2.2			
		30				12.7	11.9	11	10.2	9.2	8.1	6.8	5.4	3.4				
		40			12.5	12.2	11.4	10.5	9.6	8.5	7.5	6	4.2	1.5				
		50		12.5	12.1	11.7	10.9	10	9	7.9	6.6	5.1	2.9					
		60	12.5	12.1	11.7	11.3	10.4	9.4	8.4	7.2	5.8	4						
Shut-off PSI			210	201	193	184	167	149	132	115	97	80	63	45	28	11		
Pump Model	HP	PSI	Depth to Pumping Water Level [FT]/ Flow [GPM]															
			380	420	460	500	540	580	620	660	700	740	780	820	860	900		
10ESS - 34STG	3	0				12.6	12	11.3	10.7	9.9	9.1	8.3	7.3	6.3	5	2.6		
		20			12.5	11.9	11.2	10.5	9.8	9	8.2	7.2	6.1	4.4	2.4			
		30			12.2	11.5	10.8	10.3	9.4	8.6	7.6	6.6	5.3	3.4				
		40		12.4	11.8	11.1	10.4	9.7	8.9	8	7	5.8	4	2				
		50	12.7	12.1	11.4	10.7	10	9.3	8.4	7.5	6.4	4.9	3					
		60	12.3	11.7	11	10.3	9.7	8.8	7.9	6.9	5.7	3.8						
Shut-off PSI			243	226	208	191	174	157	139	122	105	87	70	53	35	18		
Pump Model	HP	PSI	Depth to Pumping Water Level [FT]/ Flow [GPM]															
			520	580	640	700	760	820	880	940	1000	1060	1120	1180	1240	1300		
10ESS - 48STG	5	0			12.7	12.1	11.6	11	10.4	9.8	9.1	8.3	7.4	6.5	5	3		
		20			12.3	11.7	11.2	10.6	10.1	9.4	8.5	7.6	6.7	5.5	3.6			
		30		12.5	12.1	11.5	10.9	10.3	9.8	9.1	8.2	7.3	6.3	4.8	2.6			
		40		12.3	11.8	11.3	10.7	10.3	9.4	8.7	7.8	6.9	5.8	4				
		50	12.7	12.2	11.6	11.1	10.5	9.8	9.1	8.3	7.5	6.5	5.2	3.2				
		60	12.5	11.8	11.4	10.8	10.2	9.7	8.8	8	7.1	6.1	4.4	2				
Shut-off PSI			359	333	307	281	255	229	203	177	151	125	99	73	47	21		

# MODEL 18ESS

# SIMFLO®

## PERFORMANCE CURVES

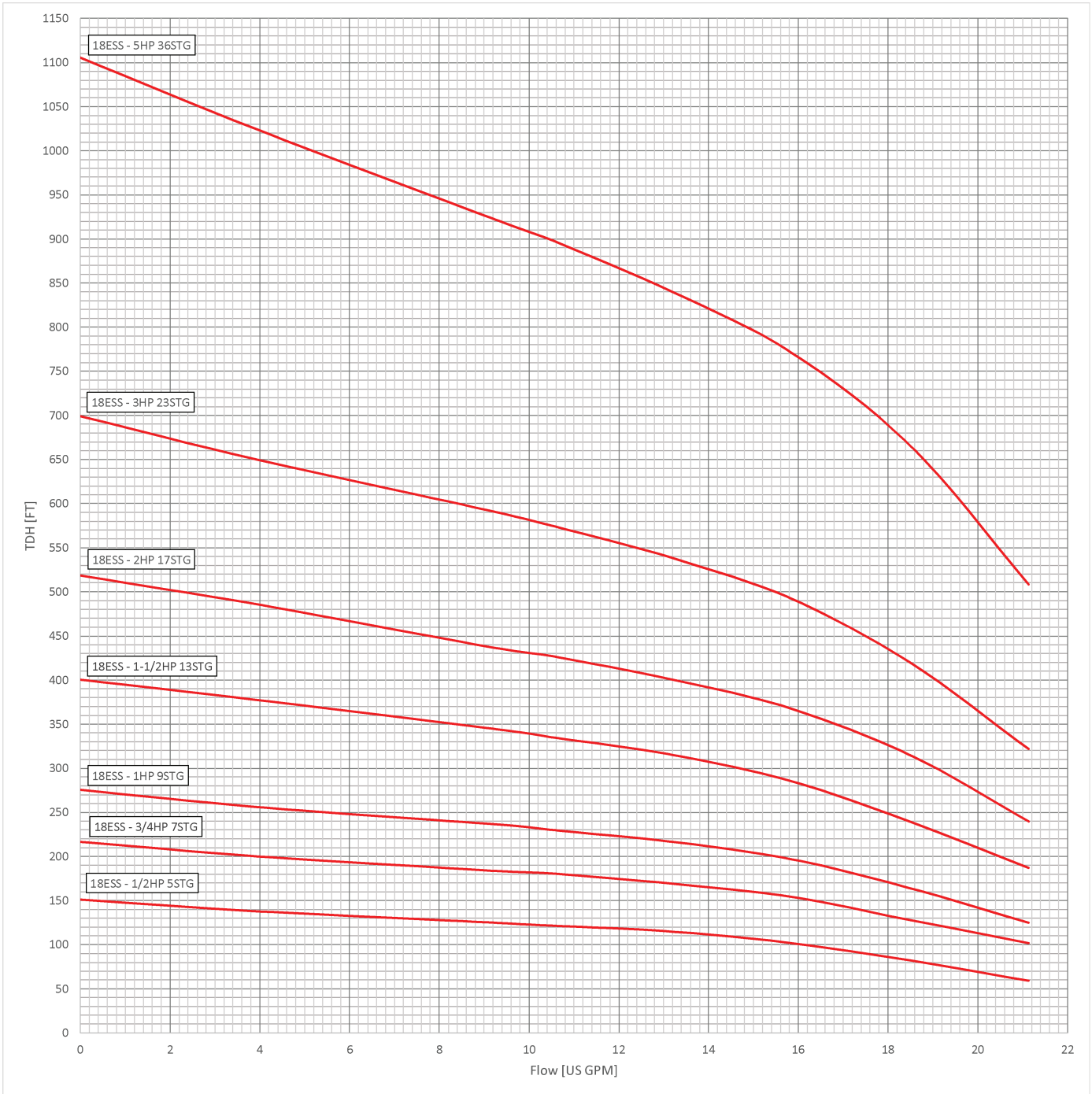

# MODEL 18ESS

# SIMFLO®

## SECTIONAL CHART

Pump Model	HP	PSI	Depth to Pumping Water Level [FT]/ Flow [GPM]									
			0	20	40	60	80	100	110	120	130	140
18ESS - 5STG	1/2	0					18.7	15.4	13.4	11.2	7	3.1
		20			17.9	15.2	8.7					
		30			17.5	14.6	7					
		40	17.1	13.7	5.9							
		50	13.2	4.8								
		60	4									
Shut-off PSI			65	57	48	39	31	22	18	13	9	5

Pump Model	HP	PSI	Depth to Pumping Water Level [FT]/ Flow [GPM]									
			20	40	60	80	100	120	140	160	180	200
18ESS - 7STG	3/4	0						19.5	17	14.2	10.7	4
		20				18.7	16.7	13.8	8.3	2.2		
		30			18.3	16.5	13	7.4	1.5			
		40	20	18	16	12.2	6.2					
		50	17.6	15.6	11.6	5.4						
		60	14.4	11.2	4.7							
Shut-off PSI			85	76	68	59	50	42	33	24	16	7

Pump Model	HP	PSI	Depth to Pumping Water Level [FT]/ Flow [GPM]									
			80	100	120	140	160	180	200	220	240	260
18ESS - 9STG	1	0					18.7	17.2	15.5	12.2	8.2	2.8
		20				16.8	14.8	11.2	6.7	1.8		
		30			16.5	14.4	10.9	6				
		40		16.3	13.7	9.8	4.5					
		50	16	13.4	9.4	4						
		60	13	9	3.6							
Shut-off PSI			85	76	67	59	50	41	33	24	15	7

Pump Model	HP	PSI	Depth to Pumping Water Level [FT]/ Flow [GPM]									
			160	180	200	220	240	260	280	300	340	380
18ESS - 13STG	1 1/2	0					18.3	17.4	16.2	14.6	9.8	3.5
		20		19.2	18.1	17	15.7	13.9	11.7	8.9	2.8	
		30	19	18	16.2	15.7	13.5	11.5	8.4	5.2		
		40	17.8	16.6	15.2	13.3	10.7	7.9	4.7			
		50	16.4	15	13.1	10.4	7.5	4.3				
		60	14.9	13	10.2	7.2	3.8					
Shut-off PSI			104	95	87	78	69	61	52	43	26	9

Pump Model	HP	PSI	Depth to Pumping Water Level [FT]/ Flow [GPM]										
			220	240	260	280	300	320	340	380	420	460	500
18ESS - 17STG	2	0					18.8	17.8	16.7	14.2	11.4	7.9	2.7
		20			18.8	17.9	17.2	15.9	14.5	10.6	5.8		
		30		18.6	17.8	16.8	15.7	14.6	12.2	7.9	3.4		
		40	18.2	17.6	16.6	15.4	13.83	11.8	9.6	5.4			
		50	17.6	16.6	15.3	13.7	11.8	9.4	7.2	2.7			
		60	16.6	15.3	13.6	11.5	9.2	6.8	5				
Shut-off PSI			129	121	112	103	95	86	77	60	43	25	8

Pump Model	HP	PSI	Depth to Pumping Water Level [FT]/ Flow [GPM]										
			300	320	340	380	420	460	500	540	580	620	660
18ESS - 23STG	3	0					18.5	17.2	15.5	13	10.5	6.8	3
		20				18.2	17.1	15.1	12.8	9.8	5.8	4.8	
		30			18.8	17.8	15.9	14	11.1	7.6	3.8		
		40	19.2	18.8	18	16.6	14.6	12.8	8.9	5.3			
		50	18.3	17.9	17.3	15.8	13.4	11.6	6.7	3.4			
		60	17.4	17.2	16.3	14.5	12.2	10.1	5.2				
Shut-off PSI			173	164	155	138	121	103	86	69	51	34	17

Pump Model	HP	PSI	Depth to Pumping Water Level [FT]/ Flow [GPM]														
			480	520	560	600	640	680	720	760	800	840	880	920	960	1000	1040
18ESS - 36STG	5	0					19	18.2	17.2	15.8	14.8	13.2	11.5	9.4	7.2	5.2	3.2
		20				18.5	17.9	17	15.9	14.4	12.8	11.6	9.8	7.5	5		
		30			19.2	17.9	17.2	16.3	15.2	13.7	11.9	9.8	8.8	6.4	3.7		
		40			18.6	17.3	16.6	15.6	14.5	12.9	10.8	8.6	7.8	5.2			
		50		19.1	18.2	16.7	15.9	14.9	13.8	12.1	9.5	7.4	6.7	3.8			
		60	19.2	18.7	17.8	16	15.5	14.2	13	11.2	8.4	6.2	5.4				
Shut-off PSI			271	254	236	219	202	184	167	150	132	115	98	80	63	46	28

## PERFORMANCE CURVES

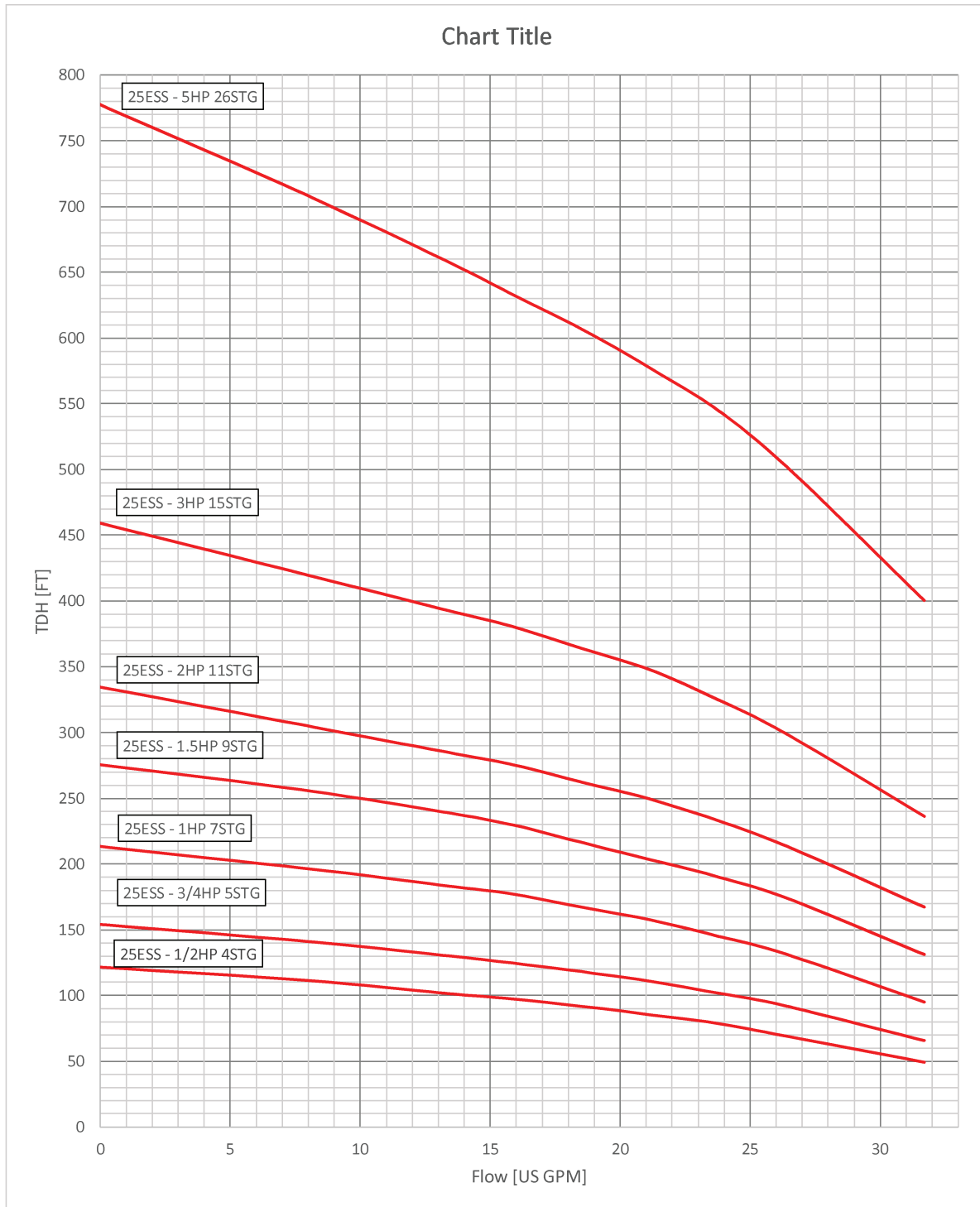



# MODEL 25ESS

# SIMFLO®

## SECTIONAL CHART

Pump Model	HP	PSI	Depth to Pumping Water Level [FT]/ Flow [GPM]					
			20	40	60	80	100	
25ESS - 4STG	1/2	0			27.8	23.2	14.3	
		20	27	20.5	10.5			
		30	19.7	9.5				
		40	6.5					
Shut-off PSI			44	35	27	18	9	

Pump Model	HP	PSI	Depth to Pumping Water Level [FT]/ Flow [GPM]						
			20	40	60	80	100	120	140
25ESS - 5STG	3/4	0				28.8	24.3	17.5	8.8
		20		27.5	22	14.3	5		
		30	27	21.8	14				
		40	20	12					
		50	11						
Shut-off PSI			58	49	41	32	23	15	6

Pump Model	HP	PSI	Depth to Pumping Water Level [FT]/ Flow [GPM]									
			20	40	60	80	100	120	140	160	180	200
25ESS - 7STG	1	0						27	25	20.5	14.8	6.3
		20			30	26.3	23.5	18.7	12.5			
		30		29.8	27	23	17.8	11				
		40	29.2	26	22.5	17	9					
		50	25.5	21.5	16.5	8.5						
		60	21	16	7							
Shut-off PSI			84	75	66	58	49	40	32	23	14	6

Pump Model	HP	PSI	Depth to Pumping Water Level [FT]/ Flow [GPM]												
			20	40	60	80	100	120	140	160	180	200	220	240	260
25ESS - 9STG	1 1/2	0								27.1	25.5	22	17.7	13	6.5
		20						27.5	24.3	20.5	16.5	11			
		30				29.5	27.3	24.3	20.5	16.2	10.5				
		40			29	26.5	22.5	19	15	9					
		50		28.5	26.3	23	17.5	14.5							
		60	28.6	26	22.5	17.5	14	7.5							
Shut-off PSI			111	102	93	85	76	67	59	50	41	33	24	15	7

Pump Model	HP	PSI	Depth to Pumping Water Level [FT]/ Flow [GPM]												
			80	100	120	140	160	180	200	220	240	260	280	300	320
25ESS - 11STG	2	0						30.2	28	26.5	22.7	19	14.5	9.3	4
		20				29.5	27.2	24.6	21.8	18	13	7.5			
		30			29.2	27.2	24.5	21.5	17.5	12.5	7				
		40		28.8	26.5	23.5	18.5	16.5	10.5	5.5					
		50	27.5	26	23.5	18	16	10.5	5						
		60	26	21.4	19.5	15.5	10	4.8							
Shut-off PSI			110	102	93	84	76	67	58	50	41	32	24	15	6

Pump Model	HP	PSI	Depth to Pumping Water Level [FT]/ Flow [GPM]													
			120	140	160	180	200	220	240	260	280	300	320	340	380	420
25ESS - 15STG	3	0								29.6	28	26.2	24.3	22	16	8
		20						27.5	27.5	25.6	23.5	21.5	18	14.5	6.5	
		30					29	26.5	25.5	23.3	21	18	14.2	10.2		
		40				28.6	27	25	23	20.8	17	13.6	9.3	5.6		
		50		30	28.5	26.6	24.6	22.5	20	16.5	13	8.8	5			
		60	29.8	28.1	26.2	24.4	21	19.2	16.4	12.3	8.5	4.3				
Shut-off PSI			147	138	130	121	112	104	95	86	78	69	60	52	34	17

Pump Model	HP	PSI	Depth to Pumping Water Level [FT]/ Flow [GPM]																
			300	320	340	360	380	400	420	440	460	480	520	560	600	640	680	720	
25ESS - 26STG	5	0									29.6	28.6	27.5	25.3	22.5	19.2	15	11	6.5
		20							29.3	28.4	27.5	26.3	25	22	18.5	14.5	10.5	5.8	
		30				30.5	29.4	28.3	27.3	26.1	25	23.5	20.2	16.3	12.3	8			
		40			30	29	28	26.7	25.8	24.6	23	21.6	17.8	14	9.8	5			
		50		29.6	28.6	27.6	26.5	26.5	24.5	23	21.3	19.5	15.5	11.5	7.4				
		60	29.8	28.8	27.6	26.6	25.4	23.5	22.8	21.3	19.2	17.5	15.5	11.5	9.2				
Shut-off PSI			207	198	189	181	172	163	155	146	137	129	111	94	77	60	42	25	

## PERFORMANCE CURVES

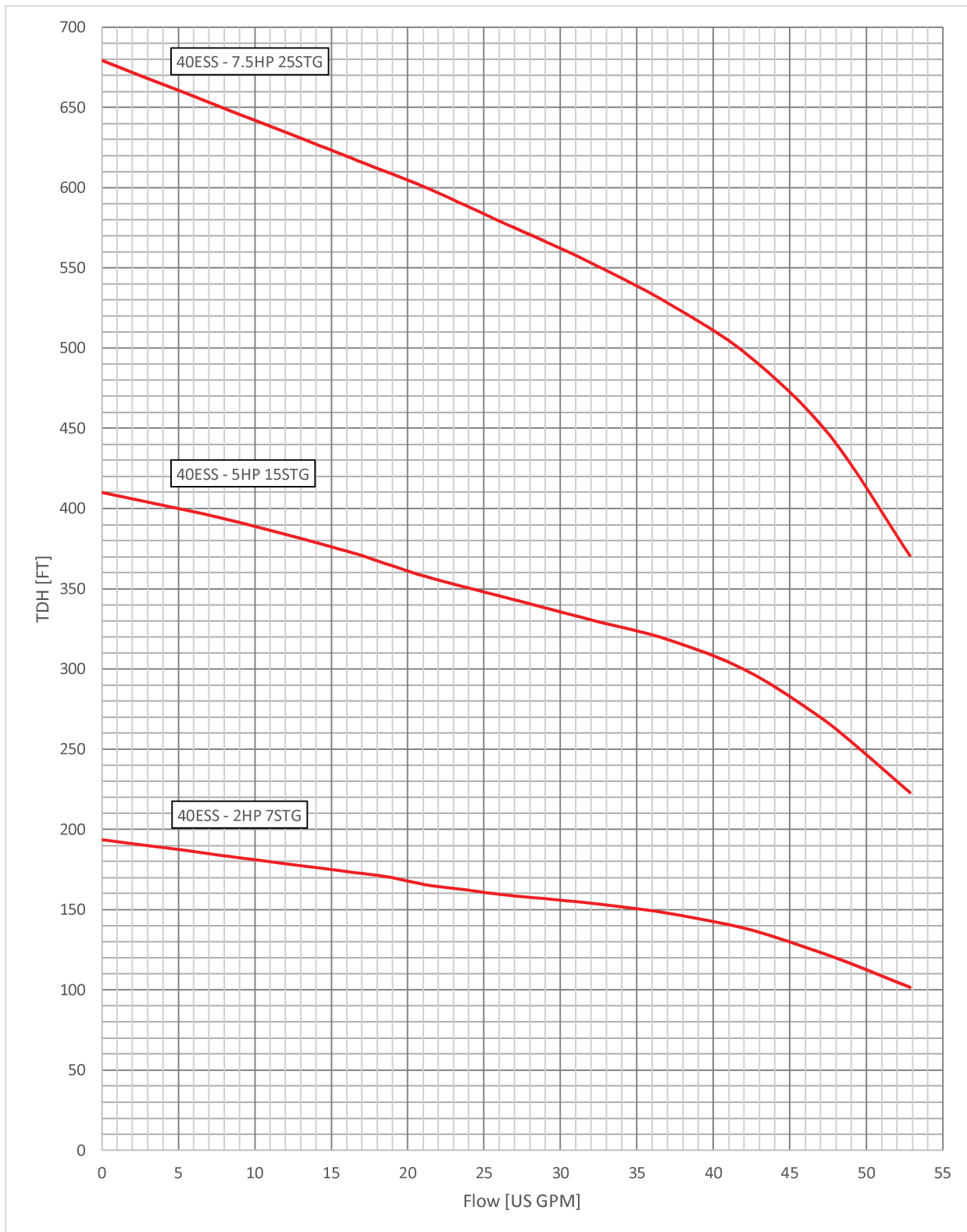

# MODEL 40ESS

# SIMFLO®

## SECTIONAL CHART

Pump Model	HP	PSI	Depth to Pumping Water Level [FT]/ Flow [GPM]								
			20	40	60	80	100	120	140	160	180
40ESS - 7STG	2	0						48	41.5	26	11
		20				46	38	21	5		
		30			45	36	19.5				
		40	50	43.5	33	16					
		50	43	31	15						
		60	27	13							
Shut-off PSI			75	66	58	49	41	32	23	15	6

Pump Model	HP	PSI	Depth to Pumping Water Level [FT]/ Flow [GPM]													
			120	140	160	180	200	220	240	260	280	300	320	340	360	400
40ESS - 15STG	5	0							50.7	48.2	45.5	41.8	36.2	28	20	5
		20					50	48	44.2	40.5	34	25.3	15	11		
		30				50	47.2	42	40	33	25	18	10.2			
		40			49	47	43.5	39	31	41.5	16	8				
		50		49	46	43	38	30	22	15	7.5					
		60	48.5	46	43	37	29.5	21	14.5	6						
Shut-off PSI			126	117	108	100	91	82	74	65	56	48	39	30	22	4

Pump Model	HP	PSI	Depth to Pumping Water Level [FT]/ Flow [GPM]													
			280	300	320	340	360	380	400	420	460	500	540	580	620	660
40ESS - 25STG	7 1/2	0								49.5	46.2	41.5	34.6	25.8	15.8	5
		20						49	47.5	45.5	40.5	33.5	24.3	14		
		30					49	48	45.6	43.5	37	28.5	19	8.2		
		40			50	49	46	45	42.7	39.5	32	21.8	12.5			
		50		49.5	49	47	44.5	43	39.1	35.5	26.6	17	6.5			
		60	49.6	48.2	46	45	42	39	35	28.5	21.8	11.4				
Shut-off PSI			173	164	155	147	138	129	121	112	95	78	60	43	26	8



**CONTACT US  
FOR THE TOOLS AND  
SERVICES YOU NEED  
TO MAKE THE MOST  
OF YOUR WATER**

**SIMFLO®**



Drinking water NSF/ANSI 31  
NSF/ANSI 372



**LUBBOCK** | 2605 INTERSTATE 27 | LUBBOCK, TX | 79404 | 806.747.3411

**WILLCOX** | 754 E MALEY ST | WILLCOX, AZ | 85643 | 520.384.2273

**SOUTHAVEN** | 8500 AARON LANE | SOUTHAVEN, MS | 38671 | 662.793.8090



**A.Y. McDonald 23000 Series - 5 GPM**

**\*\*\* 2-Wire 1ph Pump End & Motor Complete**

<u>Model</u>	<u>HP</u>	<u>Stages</u>	<u>Voltage</u>	<u>Weight</u>	<u>List Price</u>
23050J2A	1/2	13	115	30	\$ -
23050J2	1/2	13	230	30	\$ -
23075J2	3/4	18	230	36	\$ -
23100J2	1	23	230	41	\$ -
23150J2	1 1/2	30	230	49	\$ -

**3-Wire 1ph Pump End & Motor Complete**

<u>Model</u>	<u>HP</u>	<u>Stages</u>	<u>Voltage</u>	<u>Weight</u>	<u>List Price</u>
23050J3A	1/2	13	115	30	\$ -
23050J3	1/2	13	230	30	\$ -
23075J3	3/4	18	230	36	\$ -
23100J3	1	23	230	41	\$ -
23150J3	1 1/2	30	230	41	\$ -

**Pump End Only**

<u>Model</u>	<u>HP</u>	<u>Stages</u>	<u>Weight</u>	<u>List Price</u>
23050J	1/2	13	10	\$ -
23075J	3/4	18	12	\$ -
23100J	1	23	13	\$ -
23150J	1 1/2	30	18	\$ -



**A.Y. McDonald 23000 Series - 7 GPM**

**\*\*\* 2-Wire 1ph Pump End & Motor Complete**

<u>Model</u>	<u>HP</u>	<u>Stages</u>	<u>Voltage</u>	<u>Weight</u>	<u>List Price</u>
23050V2A	1/2	9	115	26	\$ -
23050V2	1/2	9	230	26	\$ -
23075V2	3/4	12	230	30	\$ -
23100V2	1	16	230	34	\$ -
23150V2	1 1/2	21	230	46	\$ -

**3-Wire 1ph Pump End & Motor Complete**

<u>Model</u>	<u>HP</u>	<u>Stages</u>	<u>Voltage</u>	<u>Weight</u>	<u>List Price</u>
23050V3A	1/2	9	115	26	\$ -
23050V3	1/2	9	230	26	\$ -
23075V3	3/4	12	230	30	\$ -
23100V3	1	16	230	35	\$ -
23150V3	1 1/2	21	230	41	\$ -
23200V3	2	26	230	49	\$ -

**Pump End Only**

<u>Model</u>	<u>HP</u>	<u>Stages</u>	<u>Weight</u>	<u>List Price</u>
23050V	1/2	9	10	\$ -
23075V	3/4	12	13	\$ -
23100V	1	16	11	\$ -
23150V	1 1/2	21	16	\$ -
23200V	2	26	18	\$ -



**A.Y. McDonald 23000 Series - 10 GPM**

**\*\*\* 2-Wire 1ph Pump End & Motor Complete**

<u>Model</u>	<u>HP</u>	<u>Stages</u>	<u>Voltage</u>	<u>Weight</u>	<u>List Price</u>
23050K2A	1/2	7	115	25	\$ -
23050K2	1/2	7	230	25	\$ -
23075K2	3/4	9	230	28	\$ -
23100K2	1	12	230	32	\$ -
23150K2	1 1/2	16	230	40	\$ -

**3-Wire 1ph Pump End & Motor Complete**

<u>Model</u>	<u>HP</u>	<u>Stages</u>	<u>Voltage</u>	<u>Weight</u>	<u>List Price</u>
23050K3A	1/2	7	115	28	\$ -
23050K3	1/2	7	230	28	\$ -
23075K3	3/4	9	230	31	\$ -
23100K3	1	12	230	35	\$ -
23150K3	1 1/2	16	230	44	\$ -
23200K3	2	20	230	46	\$ -
23300K3	3	26	230	70	\$ -
23500K3	5	33	230	89	\$ -

**Pump End Only**

<u>Model</u>	<u>HP</u>	<u>Stages</u>	<u>Weight</u>	<u>List Price</u>
23050K	1/2	7	7	\$ -
23075K	3/4	9	8	\$ -
23100K	1	12	9	\$ -
23150K	1 1/2	16	11	\$ -
23200K	2	20	14	\$ -
23300K	3	26	16	\$ -
23500K	5	33	18	\$ -





**A.Y. McDonald 23000 Series - 15 GPM**

**\*\*\* 2-Wire 1ph Pump End & Motor Complete**

<u>Model</u>	<u>HP</u>	<u>Stages</u>	<u>Voltage</u>	<u>Weight</u>	<u>List Price</u>
23050L2A	1/2	6	115	24	\$ -
23050L2	1/2	6	230	24	\$ -
23075L2	3/4	8	230	28	\$ -
23100L2	1	10	230	32	\$ -
23150L2	1 1/2	13	230	40	\$ -

**3-Wire 1ph Pump End & Motor Complete**

<u>Model</u>	<u>HP</u>	<u>Stages</u>	<u>Voltage</u>	<u>Weight</u>	<u>List Price</u>
23050L3A	1/2	6	115	24	\$ -
23050L3	1/2	6	230	24	\$ -
23075L3	3/4	8	230	28	\$ -
23100L3	1	10	230	32	\$ -
23150L3	1 1/2	13	230	37	\$ -
23200L3	2	17	230	44	\$ -
23300L3	3	23	230	58	\$ -
23500L3	5	35	230	85	\$ -

**Pump End Only**

<u>Model</u>	<u>HP</u>	<u>Stages</u>	<u>Weight</u>	<u>List Price</u>
23050L	1/2	6	7	\$ -
23075L	3/4	8	8	\$ -
23100L	1	10	9	\$ -
23150L	1 1/2	13	10	\$ -
23200L	2	17	12	\$ -
23300L	3	23	15	\$ -
23500L	5	35	22	\$ -



**A.Y. McDonald 23000 Series - 20 GPM**

**\*\*\* 2-Wire 1ph Pump End & Motor Complete**

<u>Model</u>	<u>HP</u>	<u>Stages</u>	<u>Voltage</u>	<u>Weight</u>	<u>List Price</u>
23050P2A	1/2	5	115	24	\$ -
23050P2	1/2	5	230	24	\$ -
23075P2	3/4	7	230	28	\$ -
23100P2	1	9	230	32	\$ -
23150P2	1 1/2	12	230	42	\$ -

**3-Wire 1ph Pump End & Motor Complete**

<u>Model</u>	<u>HP</u>	<u>Stages</u>	<u>Voltage</u>	<u>Weight</u>	<u>List Price</u>
23050P3A	1/2	5	115	24	\$ -
23050P3	1/2	5	230	24	\$ -
23075P3	3/4	7	230	27	\$ -
23100P3	1	9	230	32	\$ -
23150P3	1 1/2	12	230	38	\$ -
23200P3	2	14	230	43	\$ -
23300P3	3	20	230	56	\$ -
23500P3	5	32	230	84	\$ -

**Pump End Only**

<u>Model</u>	<u>HP</u>	<u>Stages</u>	<u>Weight</u>	<u>List Price</u>
23050P	1/2	5	6	\$ -
23075P	3/4	7	8	\$ -
23100P	1	9	9	\$ -
23150P	1 1/2	12	10	\$ -
23200P	2	14	11	\$ -
23300P	3	20	14	\$ -
23500P	5	32	22	\$ -



**A.Y. McDonald 23000 Series - 25 GPM**

**\*\*\* 2-Wire 1ph Pump End & Motor Complete**

<u>Model</u>	<u>HP</u>	<u>Stages</u>	<u>Voltage</u>	<u>Weight</u>	<u>List Price</u>
23050M2A	1/2	4	115	24	\$ -
23050M2	1/2	4	230	24	\$ -
23075M2	3/4	5	230	26	\$ -
23100M2	1	7	230	31	\$ -
23150M2	1 1/2	9	230	40	\$ -

**3-Wire 1ph Pump End & Motor Complete**

<u>Model</u>	<u>HP</u>	<u>Stages</u>	<u>Voltage</u>	<u>Weight</u>	<u>List Price</u>
23050M3A	1/2	4	115	24	\$ -
23050M3	1/2	4	230	24	\$ -
23075M3	3/4	5	230	26	\$ -
23100M3	1	7	230	30	\$ -
23150M3	1 1/2	9	230	36	\$ -
23200M3	2	12	230	41	\$ -
23300M3	3	16	230	53	\$ -
23500M3	5	25	230	83	\$ -

**Pump End Only**

<u>Model</u>	<u>HP</u>	<u>Stages</u>	<u>Weight</u>	<u>List Price</u>
23050M	1/2	4	7	\$ -
23075M	3/4	5	7	\$ -
23100M	1	7	8	\$ -
23150M	1 1/2	9	9	\$ -
23200M	2	12	10	\$ -
23300M	3	16	11	\$ -
23500M	5	25	18	\$ -





Submersible Pumps



# Submersible Pumps

Pump Catalog - March 2022

MORE THAN A BRAND. WE'RE A FAMILY.

## 24000 Series Stainless Steel

A.Y. McDonald offers a full line of 4" submersibles ranging from 1/2 through 5 horsepower, with flow rates ranging from 5 through 25 gallons per minute (GPM). Our 24000 submersibles offer peak capacity performance in 5, 7, 10, 15, 20, and 25 gallons per minute (GPM) models.

Powered by A.Y. McDonald stainless steel motors.

The charts on the following page will assist you in choosing the pump that meets your needs.



Drinking Water  
ANSI/NSF 61

Submersible Pumps

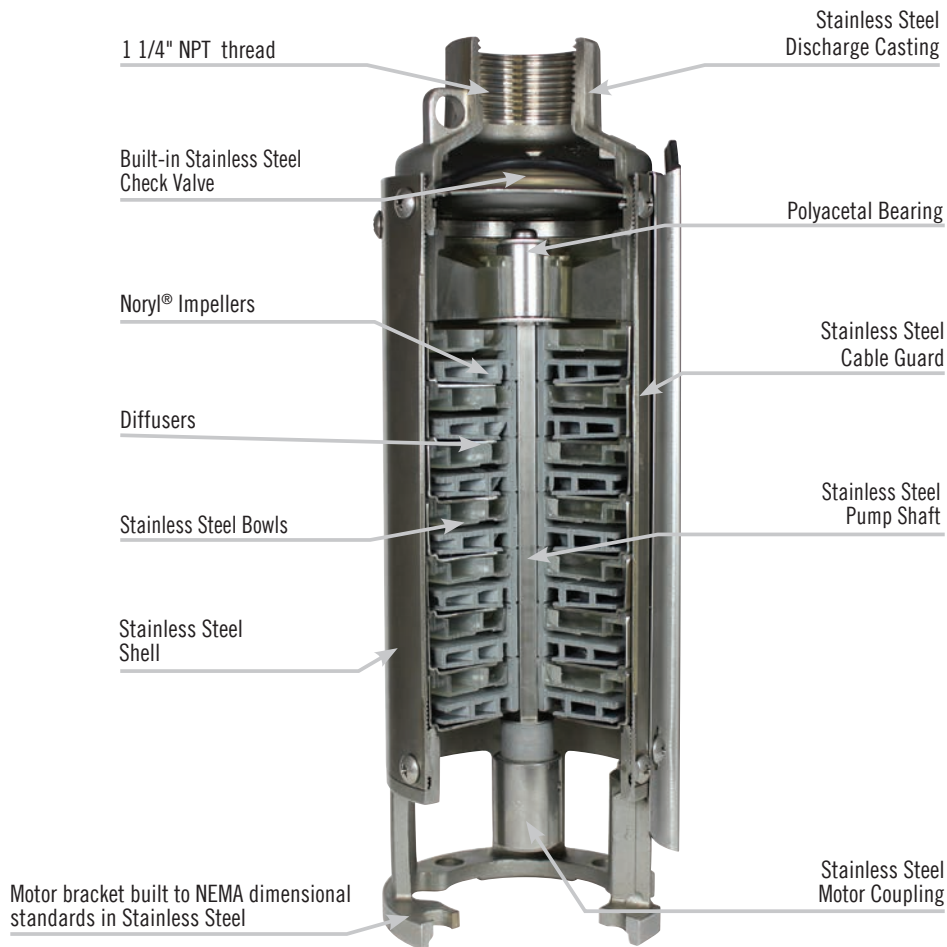

Cutaway illustrates features and is not indicative of specific model performance.

# Locating the code number on the pump

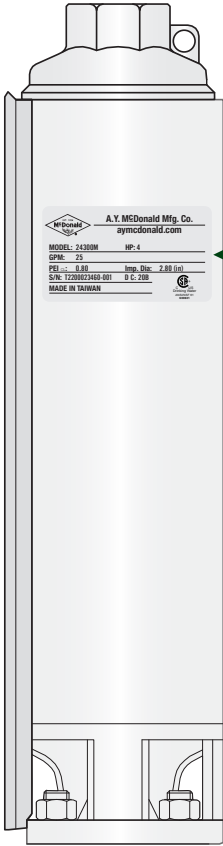

**A.Y. McDonald Mfg. Co.**  
aymcdonald.com

---

**MODEL:** 24300M      **HP:** 3

---

**GPM:** 25

---

**PEI<sub>CL</sub>:** 0.80      **Imp. Dia:** 2.80 (in)

---

**S/N:** T2200023460-001      **D C:** 20B

---

**MADE IN TAIWAN**



US  
Drinking Water  
ANSI/NSF 61  
600631

A code appears on each A.Y. McDonald 24000 series submersible pump. Contained in this code is the following information:

- Pump Model
- Date of manufacture
- Motor HP
- Pump GPM

**MATERIALS OF CONSTRUCTION**

<b>Discharge Head</b>	Stainless Steel 304, discharge 1 1/4" NPT from 5 GPM to 25 GPM series
<b>Motor Adapter</b>	Stainless Steel 304, NEMA standard
<b>Check Valve</b>	Stainless Steel 304
<b>External Shell</b>	Stainless Steel 304 polished
<b>Impellers</b>	Noryl
<b>Diffusers</b>	Polycarbonate
<b>Bearing</b>	Polyacetal
<b>Shaft Coupling</b>	Stainless Steel 304 NEMA Standard
<b>Strainer</b>	Thermoplastic
<b>Shaft</b>	Stainless Steel 304
<b>Cable Guard</b>	Stainless Steel 304

**NOTES**

- Standard is 230V, Single Phase, 60 HZ (no suffix letter required)
- Two-Wire Single phase models include; pump, motor, leads.
- Three-Wire Single phase models include; pump, motor, leads, and control box.
- Three-Wire Three phase models include; pump, motor, leads, and starter kit.
- All submersible pumps include **internal check valves and grounded lead on motor.**

Submersible Pumps

## J - 5 GPM

All Stainless Steel Submersible Pumps are designed to pump within the 5 gallons per minute (GPM) range. Sizes are available from 1/2 to 1 1/2 HP. All models are standard with 1 1/4" NPT discharge.

### Two Wire Single Phase

Part No.	Model No.	HP	Stages	Volt	A	B	Wt.
6630-233	24050J2A	1/2	12	115	14.1"	13.4"	27
6630-234	24050J2	1/2	12	230	14.1"	13.0"	30
6630-240	24075J2	3/4	15	230	16.2"	13.8"	30
6630-244	24100J2	1	20	230	19.8"	16.8"	42
6630-248	24150J2	1 1/2	26	230	25.3"	18.5"	47

### Three Wire\*\* Single Phase

Part No.	Model No.	HP	Stages	Volt	A	B	Wt.
6630-235	24050J3A	1/2	12	115	14.1"	9.5"	30
6630-236	24050J3	1/2	12	230	14.1"	10.5"	30
6630-241	24075J3	3/4	15	230	16.2"	11.3"	33
6630-245	24100J3	1	20	230	19.8"	13.6"	38
6630-249	24150J3	1 1/2	26	230	25.3"	16.2"	44

### Three Wire Three Phase

Part No.	Model No.	HP	Stages	Volt	A	B	Wt.
6630-251	24150J3Z	1 1/2	26	230	25.3"	13.6"	42

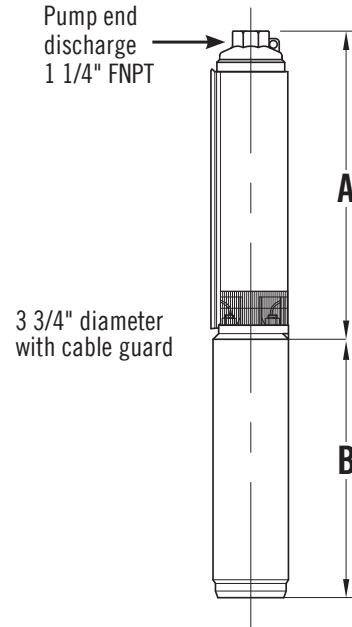

### 4" Stainless Steel Pump Ends

Part No.	Model No.	HP	Wt.
6630-232	24050J	1/2	8
6630-239	24075J	3/4	9
6630-243	24100J	1	11
6630-247	24150J	1 1/2	13

\*\* All three wire pumps are available in three phase by selecting pump end and appropriate motor and starter kit (see pages 121-136).

### Output - in Gallons Per Minute (Depth to Water)

1/2 HP	PSI	25'	50'	75'	100'	125'	150'	175'	200'	225'	250'	275'	300'	325'
	0	8.6	8.2	7.8	7.3	6.8	6.4	5.8	5.3	4.7	4.1	3.5	2.8	2.0
30	7.4	7.0	6.5	6.0	5.4	4.9	4.3	3.6	2.9	2.2	1.3			
50	6.5	6.0	5.5	5.0	4.4	3.7	3.1	2.3	1.5					
60	6.1	5.6	5.0	4.4	3.8	3.1	2.4	1.5						

3/4 HP	PSI	25'	50'	75'	100'	125'	150'	175'	200'	225'	250'	275'	300'	325'	350'	375'	400'	425'	450'
	0	8.5	8.2	7.9	7.6	7.3	7.0	6.6	6.3	5.9	5.6	5.2	4.7	4.3	3.8	3.3	2.7	2.1	1.3
30	7.7	7.4	7.0	6.7	6.4	6.0	5.6	5.3	4.8	4.4	3.9	3.4	2.9	2.2	1.5				
50	7.1	6.8	6.4	6.1	5.7	5.3	4.9	4.5	4.0	3.5	3.0	2.3	1.6						
60	6.8	6.5	6.1	5.7	5.3	4.9	4.5	4.0	3.5	3.0	2.4	1.7							

FRICITION LOSSES IN RISER PIPE HAVE NOT BEEN CALCULATED

# J - 5 GPM

Submersible Pumps

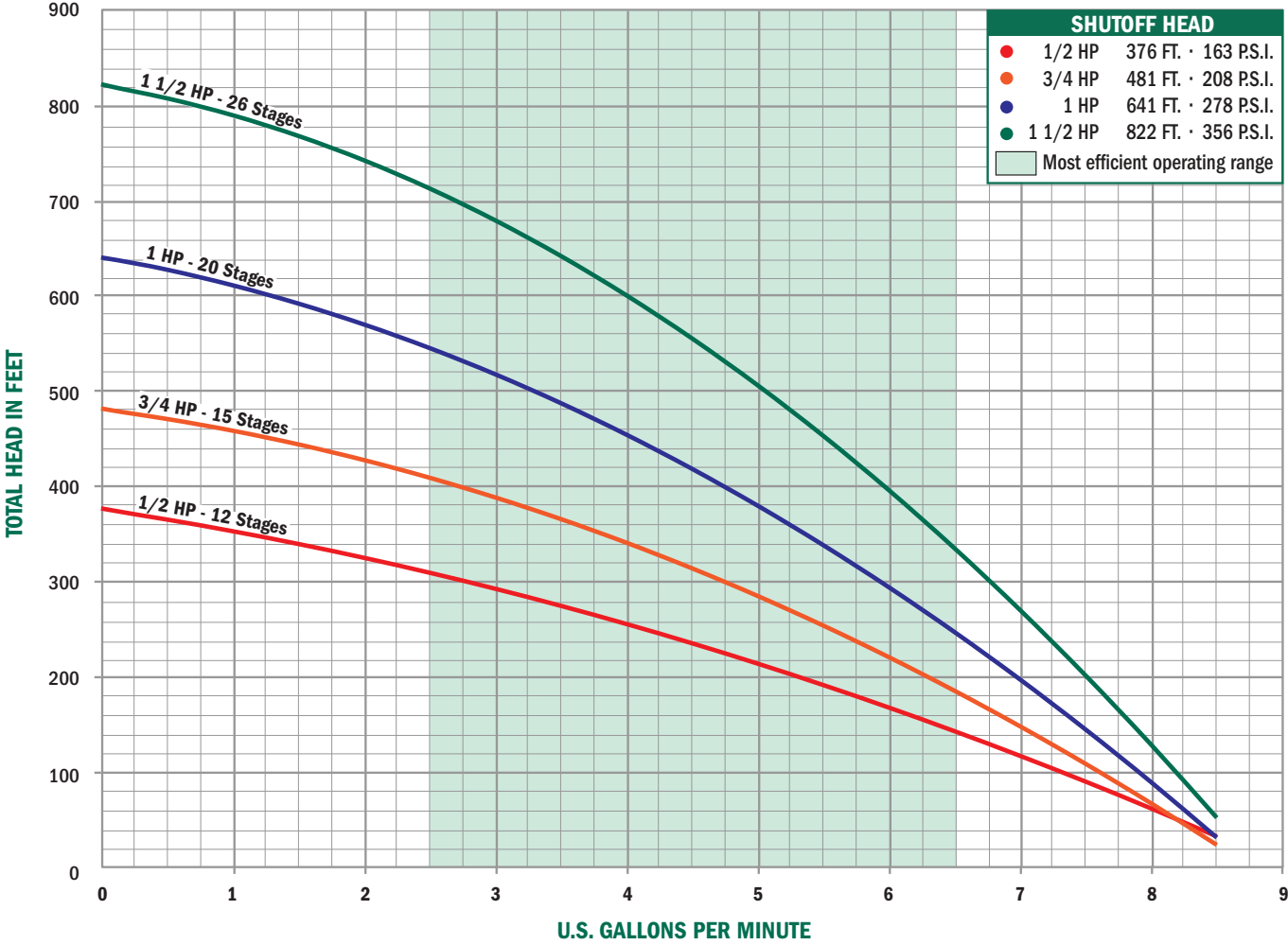

1 HP	PSI	25'	50'	75'	100'	125'	150'	175'	200'	225'	250'	275'	300'	325'	350'	375'	400'	425'	450'	475'	500'	525'	550'	575'	600'
	0	8.5	8.3	8.1	7.9	7.7	7.4	7.2	7.0	6.7	6.5	6.2	5.9	5.7	5.4	5.1	4.7	4.4	4.1	3.7	3.3	2.9	2.4	1.9	1.3
30	8.0	7.7	7.5	7.3	7.0	6.8	6.5	6.3	6.0	5.7	5.4	5.1	4.8	4.5	4.1	3.8	3.4	3.0	2.5	2.0	1.4				
50	7.5	7.3	7.1	6.8	6.6	6.3	6.0	5.8	5.5	5.2	4.9	4.5	4.2	3.8	3.5	3.0	2.6	2.1	1.5						
60	7.3	7.1	6.8	6.6	6.3	6.1	5.8	5.5	5.2	4.9	4.6	4.2	3.9	3.5	3.1	2.6	2.1	1.6							

1 1/2 HP	PSI	50'	100'	150'	200'	250'	300'	350'	400'	450'	500'	550'	600'	650'	700'	750'	800'	850'
	0	8.5	8.2	7.9	7.5	7.1	6.8	6.4	6.0	5.5	5.1	4.6	4.0	3.4	2.7	1.9		
30	8.1	7.7	7.4	7.0	6.6	6.2	5.8	5.4	4.9	4.4	3.8	3.1	2.4	1.5				
50	7.7	7.4	7.0	6.7	6.3	5.8	5.4	4.9	4.4	3.8	3.2	2.5	1.6					
60	7.6	7.2	6.9	6.5	6.1	5.6	5.2	4.7	4.1	3.5	2.9	2.1						

FRICITION LOSSES IN RISER PIPE HAVE NOT BEEN CALCULATED



## V - 7 GPM

All Stainless Steel Submersible Pumps are designed to pump within the 7 gallons per minute (GPM) range. Sizes are available from 1/2 to 2 HP. All models are standard with 1 1/4" NPT discharge.

### Two Wire Single Phase

Part No.	Model No.	HP	Stages	Volt	A	B	Wt.
6630-255	24050V2A	1/2	10	115	13.0"	13.4"	25
6630-254	24050V2	1/2	10	230	13.0"	13.0"	30
6630-261	24075V2	3/4	13	230	15.2"	13.8"	33
6630-265	24100V2	1	17	230	17.9"	16.8"	40
6630-269	24150V2	1 1/2	22	230	21.4"	18.5"	44

### Three Wire\*\* Single Phase

Part No.	Model No.	HP	Stages	Volt	A	B	Wt.
6630-257	24050V3A	1/2	10	115	13.0"	9.5"	29
6630-256	24050V3	1/2	10	230	13.0"	10.5"	29
6630-262	24075V3	3/4	13	230	15.2"	11.3"	32
6630-266	24100V3	1	17	230	17.9"	13.6"	37
6630-270	24150V3	1 1/2	22	230	21.5"	16.2"	43
6630-273	24200V3	2	27	230	26.6"	16.2"	51

### Three Wire Three Phase

Part No.	Model No.	HP	Stages	Volt	A	B	Wt.
6630-409	24150V3Z	1 1/2	22	230	21.5"	13.6"	41
6630-410	24200V3Z	2	27	230	26.6"	15.4"	49

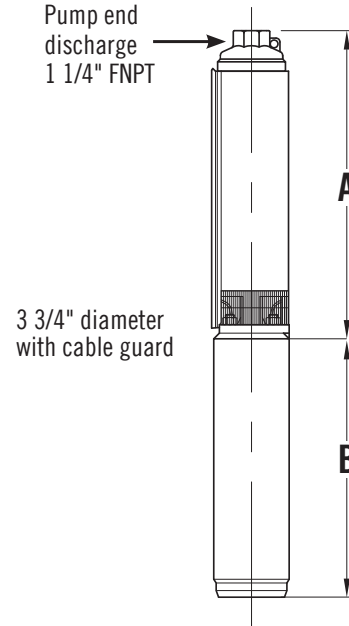

### 4" Stainless Steel Pump Ends

Part No.	Model No.	HP	Wt.
6630-253	24050V	1/2	8
6630-260	24075V	3/4	9
6630-264	24100V	1	10
6630-268	24150V	1 1/2	12
6630-272	24200V	2	15

\*\* All three wire pumps are available in three phase by selecting pump end and appropriate motor and starter kit (see pages 121-136).

### Output - in Gallons Per Minute (Depth to Water)

1/2 HP	PSI	25'	50'	75'	100'	125'	150'	175'	200'	225'	250'	275'
	0	14.8	14.0	13.1	12.2	11.2	10.1	9.0	7.8	6.4	4.9	3.0
30	12.4	11.4	10.4	9.3	8.1	6.7	5.2	3.5	1.1			
50	10.5	9.5	8.3	7.0	5.5	3.8	1.5					
60	9.5	8.4	7.1	5.6	3.9	1.7						

3/4 HP	PSI	25'	50'	75'	100'	125'	150'	175'	200'	225'	250'	275'	300'	325'	350'	375'
	0	15.3	14.6	14.0	13.4	12.7	11.9	11.2	10.4	9.5	8.6	7.7	6.6	5.4	4.0	2.3
30	13.5	12.8	12.1	11.4	10.6	9.7	8.9	7.9	6.8	5.7	4.3	2.7				
50	12.2	11.5	10.7	9.9	9.0	8.0	7.0	5.9	4.6	3.0						
60	11.5	10.8	9.9	9.1	8.1	7.1	6.0	4.7	3.1	1.0						

1 HP	PSI	25'	50'	75'	100'	125'	150'	175'	200'	225'	250'	275'	300'	325'	350'	375'	400'	425'	450'	475'	500'
	0	15.2	14.8	14.3	13.8	13.4	12.8	12.3	11.8	11.2	10.6	10.0	9.4	8.7	8.0	7.2	6.4	5.5	4.5	3.3	1.8
30	14.0	13.5	13.0	12.4	11.9	11.4	10.8	10.2	9.5	8.9	8.2	7.4	6.6	5.7	4.7	3.6	2.2				
50	13.0	12.5	12.0	11.4	10.9	10.3	9.6	9.0	8.3	7.5	6.7	5.8	4.9	3.7	2.4						
60	12.6	12.0	11.5	10.9	10.3	9.7	9.0	8.3	7.6	6.8	5.9	4.9	3.8	2.5							

FRICITION LOSSES IN RISER PIPE  
HAVE NOT BEEN CALCULATED

# V - 7 GPM

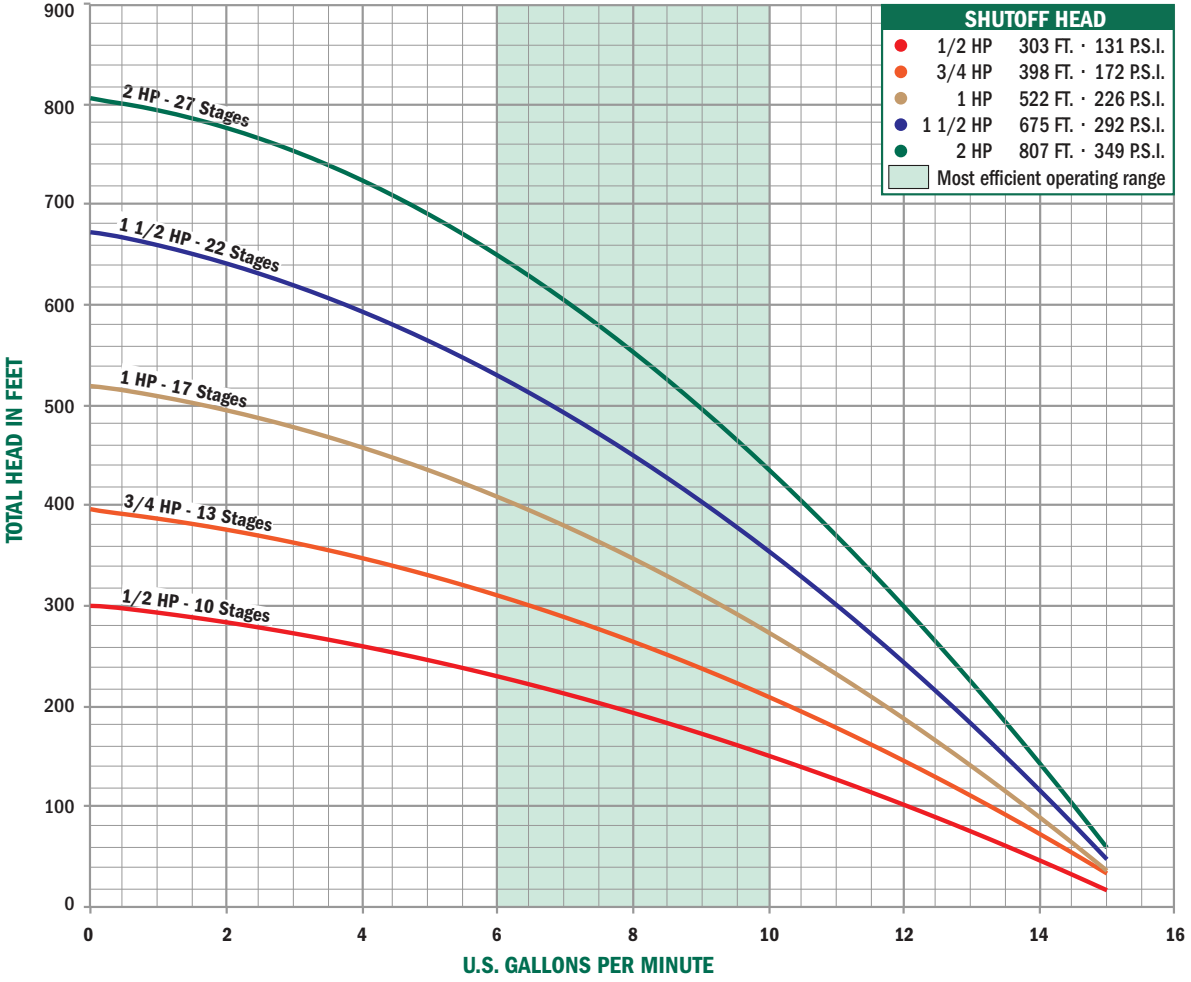

Submersible Pumps

1 1/2 HP	PSI	50'	100'	150'	200'	250'	300'	350'	400'	450'	500'	550'	600'	650'
	0	15.0	14.3	13.5	12.8	11.9	11.1	10.1	9.1	8.1	6.8	5.5	3.8	1.7
	30	14.0	13.2	12.4	11.6	10.7	9.8	8.7	7.6	6.3	4.9	3.1		
	50	13.3	12.5	11.7	10.8	9.8	8.8	7.7	6.4	5.0	3.2			
	60	12.9	12.1	11.3	10.4	9.4	8.3	7.1	5.8	4.2	2.2			

2 HP	PSI	50'	100'	150'	200'	250'	300'	350'	400'	450'	500'	550'	600'	650'	700'	750'	800'
	0	15.1	14.6	14.0	13.3	12.7	12.0	11.3	10.6	9.8	9.0	8.1	7.1	6.0	4.8	3.2	0.7
	30	14.3	13.7	13.1	12.4	11.8	11.0	10.3	9.5	8.7	7.7	6.7	5.6	4.2	2.4	0.8	
	50	13.8	13.1	12.5	11.8	11.1	10.4	9.6	8.7	7.8	6.8	5.7	4.3	2.6			
	60	13.5	12.8	12.2	11.5	10.8	10.0	9.2	8.3	7.4	6.3	5.1	3.6	1.5			

FRICITION LOSSES IN RISER PIPE HAVE NOT BEEN CALCULATED

## K - 10 GPM

All Stainless Steel Submersible Pumps are designed to pump within the 10 gallons per minute (GPM) range. Sizes are available from 1/2 to 5 HP. All models are standard with 1 1/4" NPT discharge.

### Two Wire Single Phase

Part No.	Model No.	HP	Stages	Volt	A	B	Wt.
6630-277	24050K2A	1/2	7	115	10.7"	13.4"	28
6630-276	24050K2	1/2	7	230	10.7"	13.0"	28
6630-283	24075K2	3/4	10	230	12.8"	13.8"	32
6630-287	24100K2	1	12	230	14.1"	16.8"	38
6630-291	24150K2	1 1/2	17	230	17.6"	18.5"	42

### Three Wire\*\* Single Phase

Part No.	Model No.	HP	Stages	Volt	A	B	Wt.
6630-279	24050K3A	1/2	7	115	10.7"	9.5"	28
6630-278	24050K3	1/2	7	230	10.7"	10.5"	28
6630-284	24075K3	3/4	10	230	12.8"	11.3"	31
6630-288	24100K3	1	12	230	14.1"	13.6"	35
6630-292	24150K3	1 1/2	17	230	17.6"	16.2"	41
6630-297	24200K3	2	20	230	19.6"	16.2"	47
6630-302	24300K3	3	27	230	26.0"	21.4"	57
6630-307	24500K3	5	42	230	36.1"	26.9"	93

### Three Wire Three Phase

Part No.	Model No.	HP	Stages	Volt	A	B	Wt.
6630-294	24150K3Z	1 1/2	17	230	17.6"	13.6"	39
6630-299	24200K3Z	2	20	230	19.6"	15.4"	44
6630-304	24300K3Z	3	27	230	26.0"	19.8"	53
6630-308	24500K3Z	5	42	230	36.1"	24.2"	80

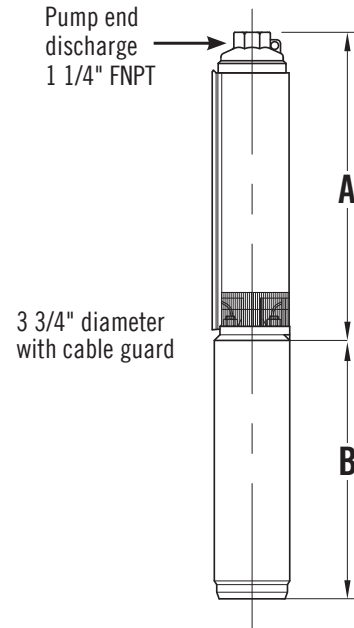

### 4" Stainless Steel Pump Ends

Part No.	Model No.	HP	Wt.
6630-275	24050K	1/2	7
6630-282	24075K	3/4	8
6630-286	24100K	1	8
6630-290	24150K	1 1/2	10
6630-296	24200K	2	11
6630-301	24300K	3	15
6630-306	24500K	5	25

\*\* All three wire pumps are available in three phase by selecting pump end and appropriate motor and starter kit (see pages 121-136).

### Output - in Gallons Per Minute (Depth to Water)

1/2 HP	PSI	25'	50'	75'	100'	125'	150'	175'	200'
	0	19.2	17.8	16.3	14.7	12.9	10.9	8.5	5.2
	30	15.1	13.4	11.4	9.1	6.1			
	50	11.7	9.5	6.6					
	60	9.7	6.9						

3/4 HP	PSI	25'	50'	75'	100'	125'	150'	175'	200'	225'	250'	275'	300'
	0	19.5	18.6	17.6	16.7	15.6	14.5	13.3	12.0	10.5	8.8	6.8	3.9
	30	16.9	15.9	14.8	13.6	12.3	10.9	9.2	7.3	4.7			
	50	14.9	13.8	12.5	11.1	9.5	7.6	5.2					
	60	13.9	12.6	11.2	9.6	7.8	5.4						

1 HP	PSI	25'	50'	75'	100'	125'	150'	175'	200'	225'	250'	275'	300'	325'	350'	375'
	0	19.4	18.6	17.8	17.0	16.2	15.3	14.3	13.3	12.3	11.1	9.8	8.4	6.7	4.5	1.0
	30	17.2	16.4	15.5	14.6	13.6	12.5	11.4	10.1	8.7	7.1	5.1	2.1			
	50	15.6	14.7	13.7	12.7	11.5	10.3	8.9	7.3	5.4	2.7					
	60	14.8	13.8	12.8	11.6	10.4	9.0	7.5	5.6	3.0						

1 1/2 HP	PSI	50'	100'	150'	200'	250'	300'	350'	400'	450'	500'
	0	19.1	18.1	17.0	15.8	14.6	13.2	11.7	10.0	7.9	5.2
	30	17.7	16.6	15.4	14.1	12.6	11.1	9.2	7.0	3.7	
	50	16.6	15.5	14.2	12.8	11.2	9.4	7.2	4.0		
	60	16.1	14.9	13.5	12.1	10.4	8.4	5.9			

FRICITION LOSSES IN RISER PIPE  
HAVE NOT BEEN CALCULATED

# K - 10 GPM

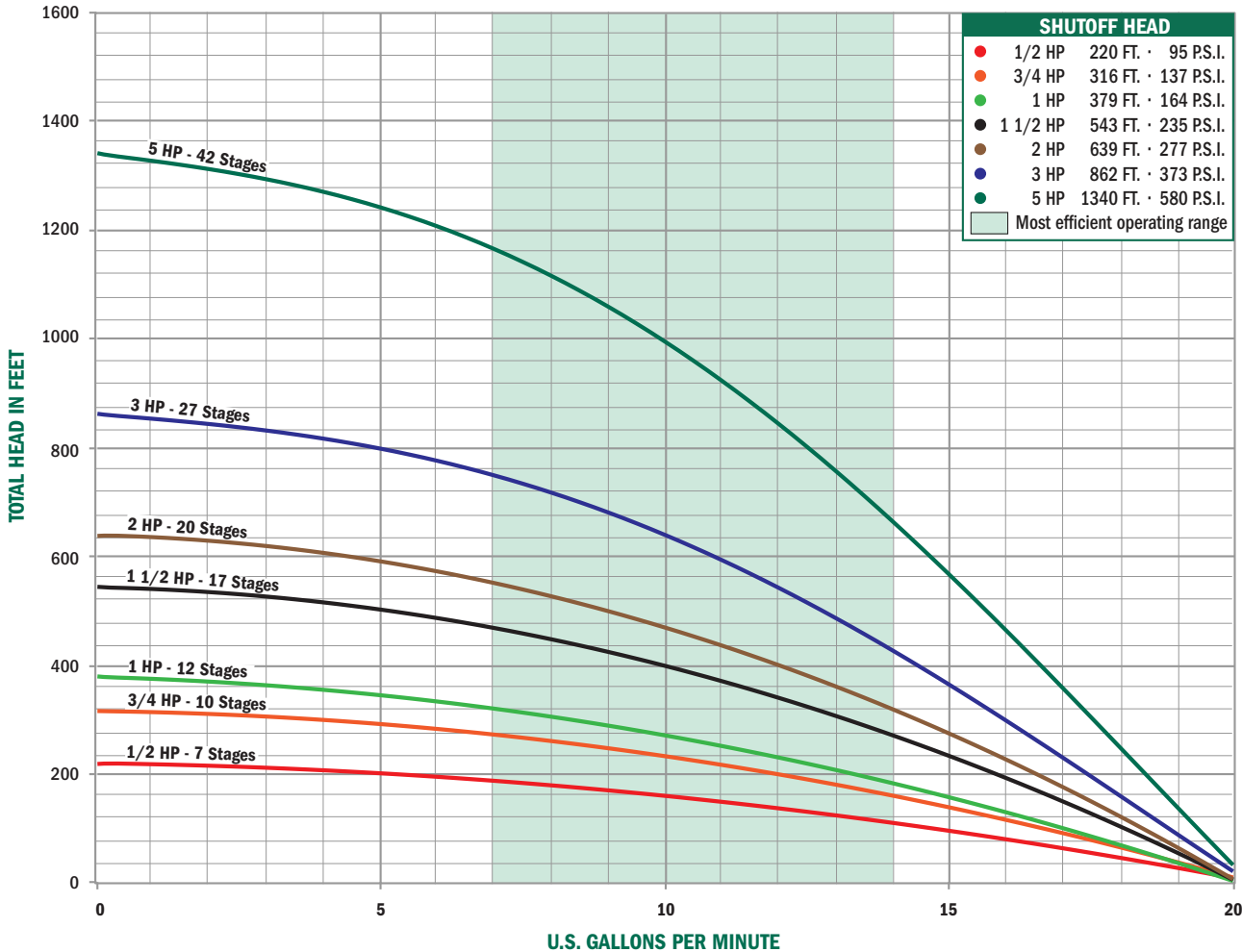

Submersible Pumps

2 HP	PSI	50'	100'	150'	200'	250'	300'	350'	400'	450'	500'	550'	600'
	0	19.3	18.4	17.5	16.5	15.5	14.4	13.3	12.0	10.6	9.0	7.1	4.5
30	18.1	17.1	16.2	15.1	14.0	12.8	11.5	10.0	8.3	6.2	3.0		
50	17.2	16.2	15.2	14.1	12.9	11.6	10.1	8.4	6.4	3.3			
60	16.8	15.8	14.7	13.6	12.3	10.9	9.4	7.5	5.1				

3 HP	PSI	50'	100'	150'	200'	250'	300'	350'	400'	450'	500'	550'	600'	650'	700'	750'	800'	850'
	0	19.6	18.9	18.2	17.4	16.7	16.0	15.2	14.4	13.6	12.8	11.9	10.9	9.8	8.5	7.0	4.9	1.4
30	18.6	17.9	17.2	16.4	15.7	14.9	14.1	13.3	12.4	11.5	10.5	9.3	8.0	6.3	3.8			
50	17.9	17.2	16.5	15.8	15.0	14.2	13.4	12.5	11.6	10.5	9.4	8.1	6.4	4.1				
60	17.6	16.9	16.2	15.4	14.6	13.8	13.0	12.1	11.2	10.0	8.8	7.4	5.5					

5 HP	PSI	50'	100'	150'	200'	250'	300'	350'	400'	450'	500'	550'	600'	650'	700'	750'	800'	850'	900'	950'	1000'	1050'	1100'	1150'	1200'	1250'	1300'
	0	19.8	19.4	18.9	18.5	18.0	17.5	17.1	16.6	16.1	15.7	15.2	14.7	14.2	13.6	13.1	12.5	11.9	11.3	10.6	9.9	9.2	8.3	7.3	6.2	4.7	2.7
30	19.2	18.7	18.3	17.8	17.4	16.9	16.4	16.0	15.5	15.0	14.5	14.0	13.4	12.9	12.3	11.7	11.1	10.4	9.6	8.8	7.9	6.9	5.7	4.0	1.5		
50	18.8	18.3	17.9	17.4	16.9	16.5	16.0	15.5	15.0	14.5	14.0	13.5	12.9	12.3	11.7	11.1	10.4	9.7	8.9	8.0	7.0	5.8	4.2				
60	18.6	18.1	17.6	17.2	16.7	16.2	15.8	15.3	14.8	14.3	13.8	13.2	12.7	12.1	11.5	10.8	10.1	9.3	8.5	7.6	6.5	5.1	3.2				

FRICITION LOSSES IN RISER PIPE HAVE NOT BEEN CALCULATED

## L - 15 GPM

All Stainless Steel Submersible Pumps are designed to pump within the 15 gallons per minute (GPM) range. Sizes are available from 1/2 to 5 HP. All models are standard with 1 1/4" NPT discharge.

### Two Wire Single Phase

Part No.	Model No.	HP	Stages	Volt	A	B	Wt.
6630-312	24050L2A	1/2	5	115	9.3"	13.4"	23.5
6630-311	24050L2	1/2	5	230	9.3"	13.0"	23.5
6630-318	24075L2	3/4	7	230	10.7"	13.8"	27.2
6630-322	24100L2	1	10	230	12.8"	16.8"	31.1
6630-326	24150L2	1 1/2	12	230	14.1"	18.5"	38.7

### Three Wire\*\* Single Phase

Part No.	Model No.	HP	Stages	Volt	A	B	Wt.
6630-314	24050L3A	1/2	5	115	9.3"	9.5"	24.5
6630-313	24050L3	1/2	5	230	9.3"	10.5"	24.5
6630-319	24075L3	3/4	7	230	10.7"	11.3"	27.2
6630-323	24100L3	1	10	230	12.8"	13.6"	31.1
6630-327	24150L3	1 1/2	12	230	14.1"	16.2"	35.7
6630-330	24200L3	2	17	230	17.6"	16.2"	42.5
6630-335	24300L3	3	21	230	20.4"	21.4"	52.1
6630-340	24500L3	5	35	230	31.6"	26.9"	88.0

### Three Wire Three Phase

Part No.	Model No.	HP	Stages	Volt	A	B	Wt.
6630-411	24150L3Z	1 1/2	12	230	14.1"	13.6"	31.7
6630-332	24200L3Z	2	17	230	17.6"	15.4"	37.5
6630-337	24300L3Z	3	21	230	20.4"	19.8"	46.1
6630-342	24500L3Z	5	35	230	31.6"	24.2"	73.0

\*\* All three wire pumps are available in three phase by selecting pump end and appropriate motor and starter kit (see pages 121-136).

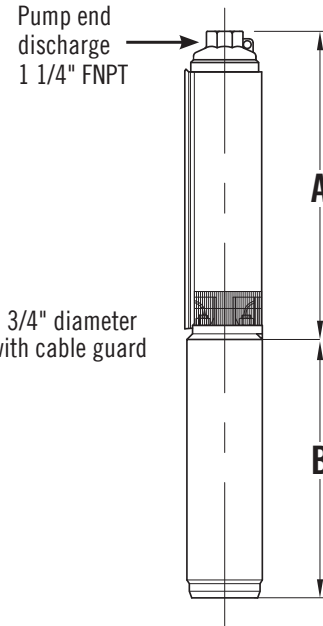

### 4" Stainless Steel Pump Ends

Part No.	Model No.	HP	Wt.
6630-310	24050L	1/2	6
6630-317	24075L	3/4	7
6630-321	24100L	1	8
6630-325	24150L	1 1/2	9
6630-329	24200L	2	10
6630-334	24300L	3	12
6630-339	24500L	5	17

### Output - in Gallons Per Minute (Depth to Water)

1/2 HP	PSI	25'	50'	75'	100'	125'	150'
	0	22.7	20.4	17.8	14.6	10.6	3.1
	30	15.4	11.7	5.8	9.1	6.1	
	50	7.0	9.5	6.6			

3/4 HP	PSI	25'	50'	75'	100'	125'	150'	175'	200'
	0	23.3	21.7	20.0	18.1	16.0	13.6	10.5	6.0
	30	18.6	16.5	14.2	11.3	7.3			
	50	14.6	11.8	8.1					
60	12.0	8.4							

1 HP	PSI	25'	50'	75'	100'	125'	150'	175'	200'	225'	250'	275'
	0	23.8	22.7	21.6	20.4	19.1	17.7	16.2	14.5	12.6	10.4	7.4
	30	20.6	19.4	18.0	6.6	14.9	13.1	10.9	8.2	3.6		
	50	18.2	16.8	15.2	13.4	11.3	8.7	4.7				
60	16.9	15.3	13.5	11.5	8.9	5.1						

1 1/2 HP	PSI	25'	50'	75'	100'	125'	150'	175'	200'	225'	250'	275'	300'	325'	350'
	0	23.9	23.1	22.1	21.2	20.2	19.1	18.0	16.8	15.5	14.1	12.6	10.8	8.6	5.6
	30	21.4	20.4	19.4	18.3	17.1	15.8	14.5	12.9	11.2	9.1	6.4			
	50	19.5	18.4	17.3	16.0	14.7	13.2	11.5	9.5	6.9					
60	18.5	17.4	16.1	14.8	13.3	11.6	9.6	7.1							

FRICITION LOSSES IN RISER PIPE  
HAVE NOT BEEN CALCULATED

# L - 15 GPM

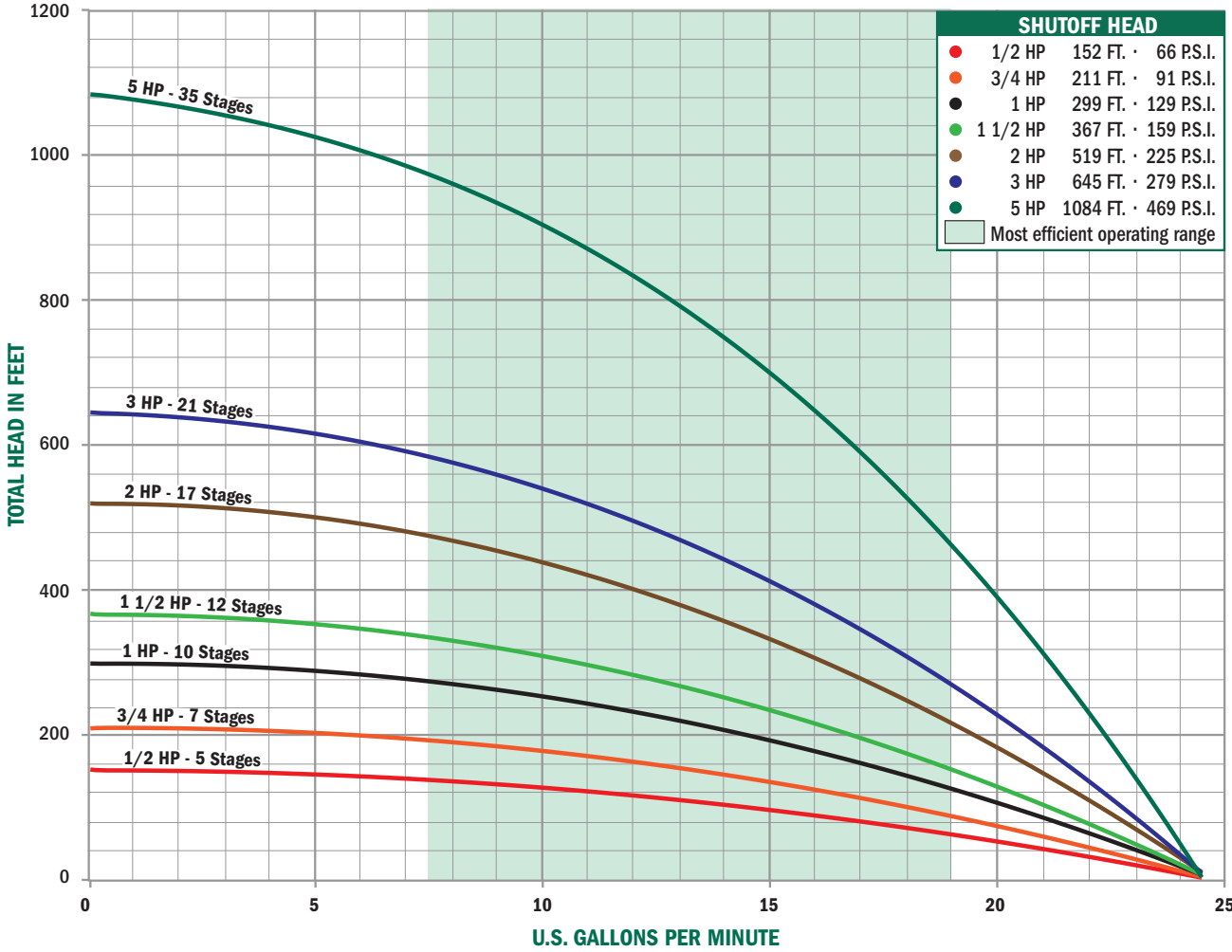

Submersible Pumps

2 HP	PSI	50'	100'	150'	200'	250'	300'	350'	400'	450'	500'
	0	23.6	22.3	21.0	19.5	17.9	16.2	14.3	12.1	9.3	5.1
	30	21.8	20.4	18.9	17.3	15.5	13.5	11.1	7.9		
	50	20.5	19.0	17.4	15.7	13.7	11.3	8.2			
	60	19.8	18.3	16.6	14.8	12.6	10.0	6.3			

3 HP	PSI	50'	100'	150'	200'	250'	300'	350'	400'	450'	500'	550'	600'
	0	23.8	22.8	21.7	20.6	19.5	18.2	16.9	15.4	13.7	11.8	9.5	6.4
	30	22.4	21.3	20.2	19.0	17.7	16.3	14.8	13.0	11.0	8.4	4.7	
	50	21.4	20.3	19.1	17.8	16.4	14.9	13.2	11.1	8.6	5.0		
	60	20.9	19.8	18.5	17.2	15.7	14.1	12.3	10.1	7.2	2.0		

5 HP	PSI	50'	100'	150'	200'	250'	300'	350'	400'	450'	500'	550'	600'	650'	700'	750'	800'	850'	900'	950'	1000'
	0	24.0	23.5	23.0	22.4	21.8	21.2	20.5	19.9	19.2	18.4	17.6	16.8	15.9	15.0	14.0	12.8	11.5	10.1	8.4	6.3
	30	23.3	22.7	22.2	21.6	20.9	20.3	19.6	18.9	18.1	17.3	16.5	15.6	14.6	13.5	12.3	11.0	9.5	7.7	5.3	
	50	22.8	22.2	21.6	21.0	20.3	19.7	18.9	18.2	17.4	16.6	15.6	14.7	13.6	12.4	11.1	9.6	7.8	5.5		
	60	22.5	21.9	21.3	20.7	20.0	19.3	18.6	17.8	17.0	16.1	15.2	14.2	13.1	11.9	10.5	8.8	6.8			

FRICITION LOSSES IN RISER PIPE HAVE NOT BEEN CALCULATED

## P - 20 GPM

All Stainless Steel Submersible Pumps are designed to pump within the 20 gallons per minute (GPM) range. Sizes are available from 1/2 to 5 HP. All models are standard with 1 1/4" NPT discharge.

### Two Wire Single Phase

Part No.	Model No.	HP	Stages	Volt	A	B	Wt.
6630-346	24050P2A	1/2	5	115	10.1"	13.4"	24.0
6630-345	24050P2	1/2	5	230	10.1"	13.0"	24.0
6630-352	24075P2	3/4	6	230	11.0"	13.8"	27.2
6630-356	24100P2	1	8	230	12.7"	16.8"	30.9
6630-360	24150P2	1 1/2	11	230	15.2"	18.5"	39.0

### Three Wire\*\* Single Phase

Part No.	Model No.	HP	Stages	Volt	A	B	Wt.
6630-348	24050P3A	1/2	5	115	10.1"	9.5"	25.0
6630-347	24050P3	1/2	5	230	10.1"	10.5"	25.0
6630-353	24075P3	3/4	6	230	11.0"	11.3"	27.2
6630-357	24100P3	1	8	230	12.7"	13.6"	30.9
6630-361	24150P3	1 1/2	11	230	15.2"	16.2"	36.0
6630-366	24200P3	2	14	230	17.8"	16.2"	42.1
6630-371	24300P3	3	19	230	22.0"	21.4"	51.8
6630-376	24500P3	5	30	230	32.6"	26.9"	87.0

### Three Wire Three Phase

Part No.	Model No.	HP	Stages	Volt	A	B	Wt.
6630-363	24150P3Z	1 1/2	11	230	15.2"	13.6"	32.0
6630-368	24200P3Z	2	14	230	17.8"	15.4"	37.1
6630-373	24300P3Z	3	19	230	22.0"	19.8"	45.8
6630-380	24500P3Z	5	30	230	32.6"	24.2"	72.0

\*\* All three wire pumps are available in three phase by selecting pump end and appropriate motor and starter kit (see pages 121-136).

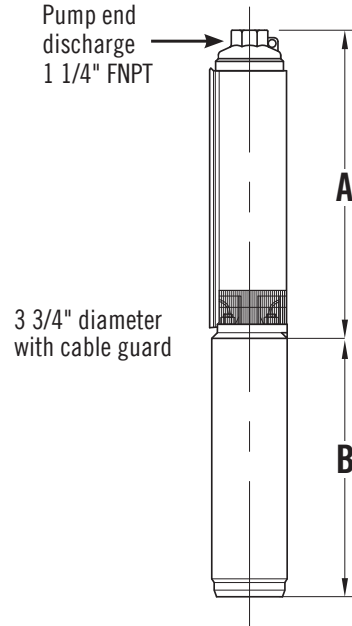

### 4" Stainless Steel Pump Ends

Part No.	Model No.	HP	Wt.
6630-344	24050P	1/2	6
6630-351	24075P	3/4	7
6630-355	24100P	1	8
6630-359	24150P	1 1/2	9
6630-365	24200P	2	10
6630-370	24300P	3	12
6630-375	24500P	5	17

### Output - in Gallons Per Minute (Depth to Water)

1/2 HP	PSI	25'	50'	75'	100'	125'
	0	30.3	26.8	22.8	18.0	11.6
	30	19.2	13.3			
	50	4.8				

3/4 HP	PSI	25'	50'	75'	100'	125'	150'	175'
	0	32.3	29.6	26.5	23.1	19.1	14.1	6.2
	30	23.9	20.1	15.4	8.6			
	50	16.2	9.9					
60	10.5							

1 HP	PSI	25'	50'	75'	100'	125'	150'	175'	200'	225'
	0	33.0	31.0	28.8	26.5	24.0	21.2	18.0	14.1	8.8
	30	27.1	24.6	21.9	18.7	15.1	10.2			
	50	22.3	19.2	15.7	11.1					
60	19.5	16.0	11.5							

1 1/2 HP	PSI	25'	50'	75'	100'	125'	150'	175'	200'	225'	250'	275'	300'	325'
	0	33.2	32.0	30.7	29.4	27.9	26.3	24.5	22.5	20.2	17.5	14.2	9.9	4.1
	30	29.7	28.2	26.6	24.9	23.0	20.7	18.2	15.0	11.0	5.6			
	50	26.9	25.2	23.3	21.1	18.6	15.5	11.7	6.5					
60	25.3	23.4	21.3	18.8	15.8	12.0	7.0							

FRICITION LOSSES IN RISER PIPE  
HAVE NOT BEEN CALCULATED

# P - 20 GPM

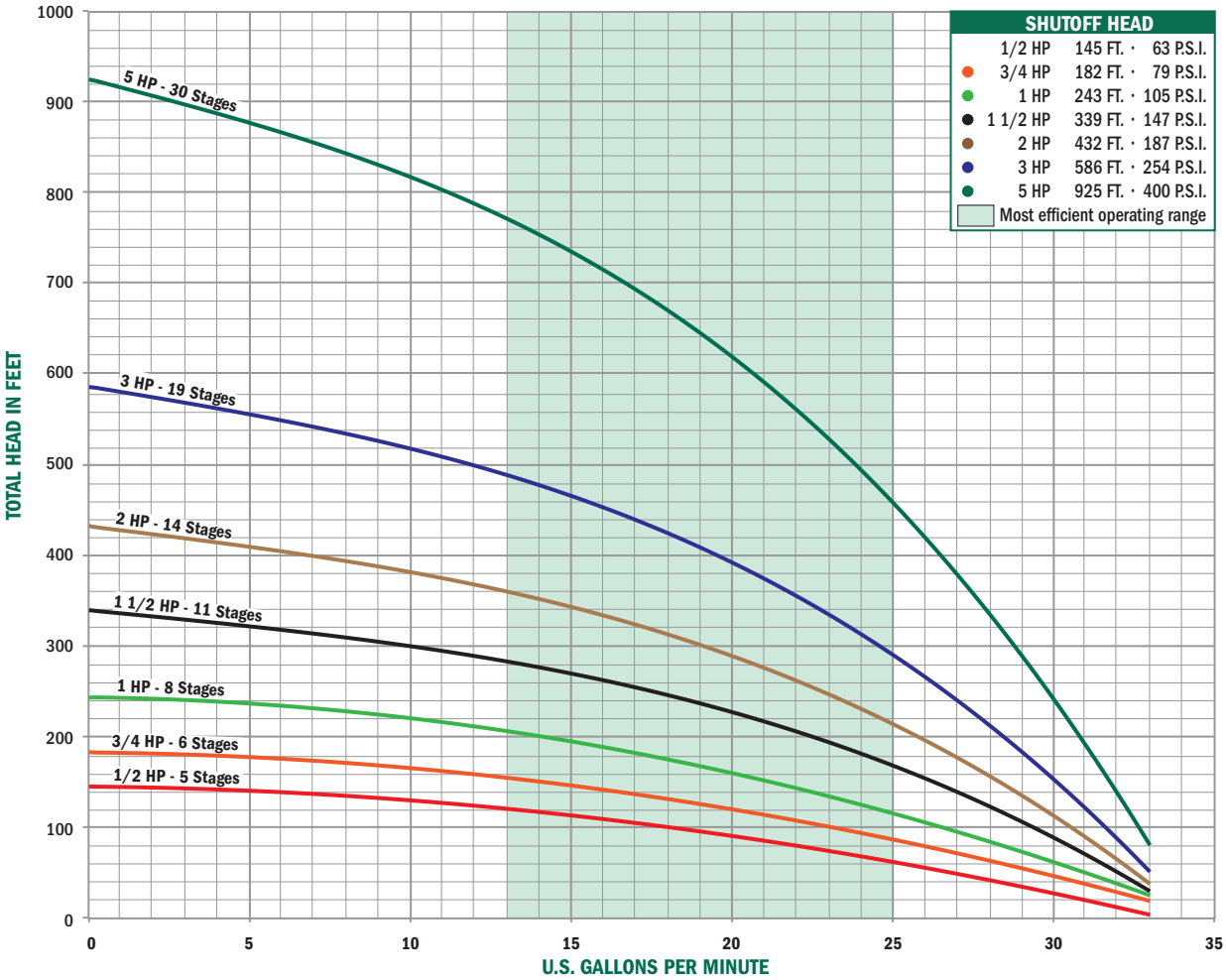

Submersible Pumps

2 HP	PSI	25'	50'	75'	100'	125'	150'	175'	200'	225'	250'	275'	300'	325'	350'	375'	400'
	0	33.5	32.5	31.6	30.5	29.5	28.3	27.1	25.8	24.3	22.8	21.1	19.1	16.9	14.2	10.9	6.8
	30	30.8	29.7	28.6	27.4	26.1	24.7	23.2	21.5	19.6	17.4	14.8	11.8	7.8			
	50	28.8	27.6	26.3	24.9	23.4	21.7	19.9	17.7	15.3	12.3	8.5					
	60	27.7	26.4	25.0	23.5	21.9	20.0	17.9	15.5	12.5	8.8						

3 HP	PSI	50'	100'	150'	200'	250'	300'	350'	400'	450'	500'	550'
	0	33.0	31.6	30.1	28.4	26.6	24.6	22.3	19.5	16.2	11.9	5.8
	30	31.0	29.5	27.8	25.9	23.7	21.3	18.3	14.7	9.8	2.8	
	50	29.6	27.9	26.0	23.9	21.5	18.6	15.0	10.2	3.4		
	60	28.8	27.1	25.1	22.8	20.2	17.0	13.0	7.4			

5 HP	PSI	50'	100'	150'	200'	250'	300'	350'	400'	450'	500'	550'	600'	650'	700'	750'	800'	850'	900'
	0	33.5	32.7	31.8	30.8	29.8	28.8	27.7	26.5	25.2	23.8	22.3	20.7	18.8	16.7	14.2	11.2	7.4	2.7
	30	32.3	31.4	30.4	29.4	28.4	27.2	26.0	24.7	23.3	21.7	20.0	18.0	15.8	13.1	9.8	5.7		
	50	31.5	30.5	29.5	28.4	27.3	26.1	24.8	23.4	21.8	20.1	18.2	16.0	13.3	10.1	6.0			
	60	31.0	30.1	29.0	27.9	26.8	25.5	24.2	22.7	21.1	19.3	17.2	14.8	11.9	8.4	3.8			

FRICITION LOSSES IN RISER PIPE HAVE NOT BEEN CALCULATED



## M - 25 GPM

All Stainless Steel Submersible Pumps are designed to pump within the 25 gallons per minute (GPM) range. Sizes are available from 1 to 5 HP. All models are standard with 1 1/4" NPT discharge.

### Two Wire Single Phase

Part No.	Model No.	HP	Stages	Volt	A	B	Wt.
6630-383	24100M2	1	7	230	12.6"	16.8"	30.9
6630-387	24150M2	1 1/2	9	230	14.6"	18.5"	38.7

### Three Wire\*\* Single Phase

Part No.	Model No.	HP	Stages	Volt	A	B	Wt.
6630-384	24100M3	1	7	230	12.6"	13.6"	30.9
6630-388	24150M3	1 1/2	9	230	14.6"	16.2"	35.7
6630-393	24200M3	2	11	230	16.5"	16.2"	41.6
6630-398	24300M3	3	15	230	20.4"	21.4"	51.4
6630-403	24500M3	5	26	230	32.5"	26.9"	86.7

### Three Wire Three Phase

Part No.	Model No.	HP	Stages	Volt	A	B	Wt.
6630-390	24150M3Z	1 1/2	9	230	14.6"	13.6"	31.7
6630-395	24200M3Z	2	11	230	16.5"	15.4"	36.6
6630-400	24300M3Z	3	15	230	20.4"	19.8"	45.4
6630-407	24500M3Z	5	26	230	32.5"	24.2"	71.7

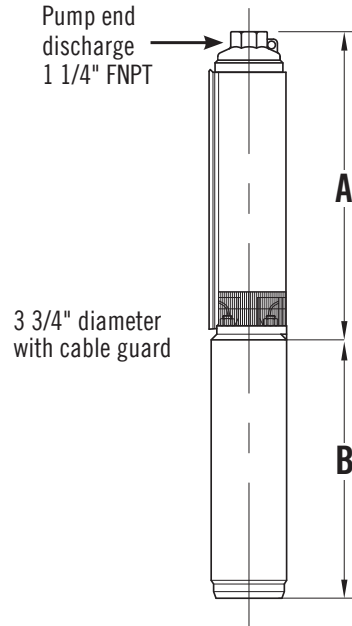

### 4" Stainless Steel Pump Ends

Part No.	Model No.	HP	Wt.
6630-382	24100M	1	7
6630-386	24150M	1 1/2	9
6630-392	24200M	2	10
6630-397	24300M	3	12
6630-402	24500M	5	16

\*\* All three wire pumps are available in three phase by selecting pump end and appropriate motor and starter kit (see pages 121-136).

### Output - in Gallons Per Minute (Depth to Water)

1 HP	PSI	25'	50'	75'	100'	125'	150'	175'	200'
	0	38.5	35.9	33.0	29.8	26.2	22.0	16.6	7.7
	30	30.5	27.0	23.0	18.0	10.5			
	50	23.7	18.8	12.0					

1 1/2 HP	PSI	25'	50'	75'	100'	125'	150'	175'	200'	225'	250'
	0	39.9	37.4	34.9	32.5	30.0	27.4	24.5	21.2	16.9	9.7
	30	33.1	30.6	28.0	25.2	22.0	18.0	11.9			
	50	28.4	25.7	22.5	18.7	13.1					
60	25.9	22.8	19.0	13.7							

2 HP	PSI	25'	50'	75'	100'	125'	150'	175'	200'	225'	250'	275'	300'
	0	37.4	36.1	34.8	33.4	31.8	30.1	28.2	26.1	23.5	20.4	16.2	9.7
	30	33.7	32.2	30.5	28.7	26.6	24.1	21.1	17.3	11.5	1.9		
	50	30.8	29.0	26.9	24.5	21.6	17.9	12.6	3.6				
60	29.1	27.1	24.7	21.9	18.3	13.1	4.4						

FRICITION LOSSES IN RISER PIPE  
HAVE NOT BEEN CALCULATED

# M - 25 GPM

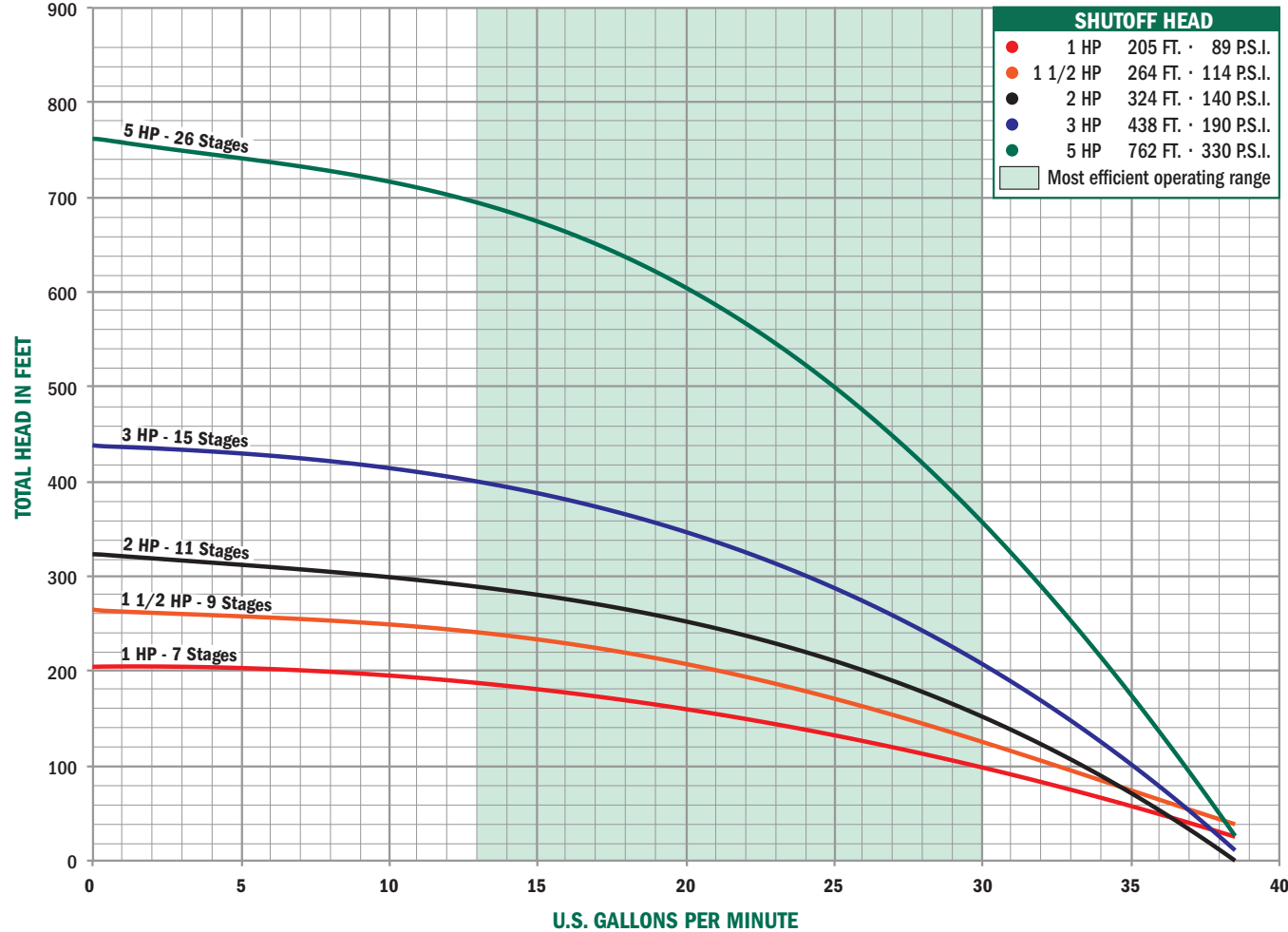

Submersible Pumps

3 HP	PSI	25'	50'	75'	100'	125'	150'	175'	200'	225'	250'	275'	300'	325'	350'	375'	400'	425'
	0	38.0	37.1	36.1	35.1	34.0	32.9	31.7	30.4	29.0	27.5	25.9	24.1	22.0	19.7	16.8	13.0	6.9
30	35.3	34.2	33.1	31.9	30.7	29.3	27.9	26.3	24.5	22.5	20.0	17.5	14.0	8.7				
50	33.3	32.1	30.9	29.5	28.1	26.5	24.8	22.8	20.6	18.0	14.6	9.7						
60	32.2	31.0	29.7	28.2	26.7	24.9	23.0	20.8	18.2	14.9	10.2							

5 HP	PSI	50'	100'	150'	200'	250'	300'	350'	400'	450'	500'	550'	600'	650'	700'
	0	38.0	36.8	35.6	34.4	33.1	31.7	30.2	28.6	26.9	25.0	22.8	20.2	17.0	12.3
30	36.4	35.1	33.9	32.5	31.1	29.6	28.0	26.2	24.2	21.9	19.1	15.4	9.5		
50	35.2	34.0	32.6	31.2	29.7	28.1	26.3	24.3	22.1	19.3	15.8	10.1			
60	34.7	33.4	32.0	30.5	29.0	27.3	25.4	23.3	20.9	17.8	13.6				

FRICITION LOSSES IN RISER PIPE HAVE NOT BEEN CALCULATED

## 24000 Series High Flow

A.Y. McDonald offers a full line of 4" submersibles ranging from 1 through 10 horsepower, with flow rates ranging from 35 through 80 gallons per minute (GPM). Our 24000 high flow submersibles offer peak capacity performance in 35, 40, 55, 60, and 80 gallons per minute (GPM) models.

- Powered by A.Y. McDonald stainless steel motors
- Delivery: up to 124 GPM at 3450 rpm
- Head: up to 1300' at 3450 rpm
- The charts on the following page will assist you in choosing the pump that meets your needs.

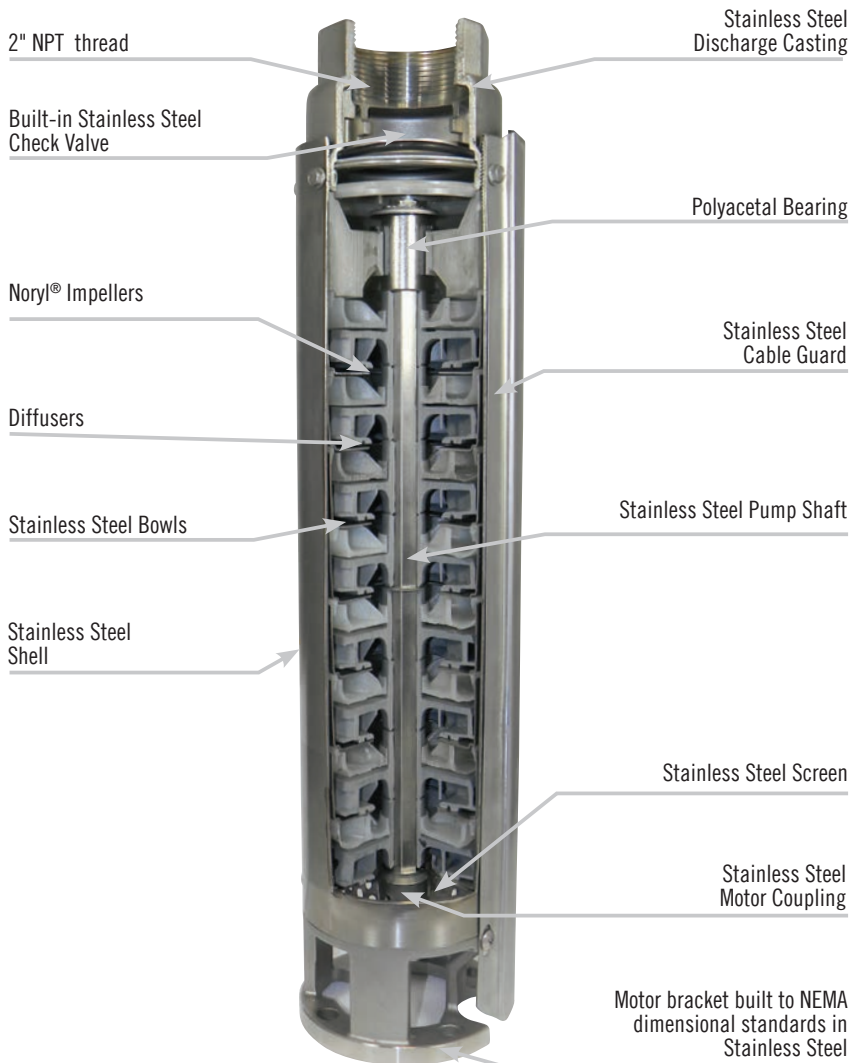

# How to Order 4" Submersible Pumps

Order by Model Number - Example: 24200R3

<b>24</b>	<b>200</b>	<b>R</b>	<b>3</b>		
<b>Series</b> Stainless Steel	<b>Horsepower</b> 100 - 1 HP 150 - 1 1/2 HP 200 - 2 HP 300 - 3 HP 500 - 5 HP 750 - 7 1/2 HP 1000 - 10 HP	<b>GPM</b> R - 35 GPM G - 40 GPM S - 55 GPM Q - 60 GPM T - 80 GPM	<b>Wires</b> Two wire or Three wire	<b>Other</b> Leave blank for 230V 60 HZ, Single Phase (Standard) <b>Other Options - Contact Factory</b> Z - 230V Three Phase Y - 460V Three Phase	<b>Controls</b> Leave blank for Control (Standard) <b>LB</b> - Less box (Single Phase Option) <b>LS</b> - Less starter (Three Phase Option)

Model 24200R3 is a 2 HP, three wire, 230 volt, single phase stainless steel 4" high flow submersible pump, designed to pump in the 35 GPM range.

## NOTES

- Standard is 230V, Single Phase, 60 HZ (no suffix letter required)
- **Two-Wire Single phase** models include; pump, motor, leads.
- **Three-Wire Single phase** models include; pump, motor, leads, and control box.
- **Three-Wire Three phase** models include; pump, motor, leads, and starter kit.
- All submersible pumps include **internal check valves and grounded lead on motor.**

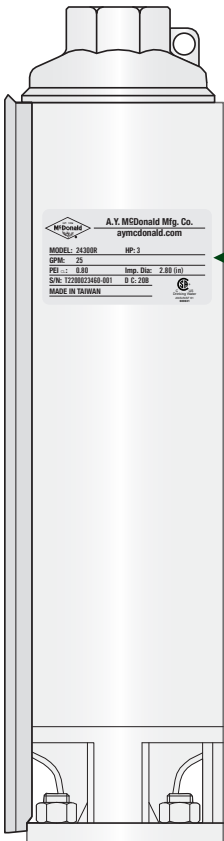

## Locating the code number on the pump

**A.Y. McDonald Mfg. Co.**  
aymcdonald.com

---

**MODEL: 24300R      HP: 3**

---

**GPM: 25**

---

**PEI CL: 0.80      Imp. Dia: 2.80 (in)**

---

**S/N: T2200023460-001      D C: 20B**

---

**MADE IN TAIWAN**



US  
Drinking Water  
ANSI/NSF 61  
600651

A code appears on each A.Y. McDonald 24000 series submersible pump. Contained in this code is the following information:

- Pump Model
- Date of manufacture
- Motor HP
- Pump GPM

### MATERIALS OF CONSTRUCTION

<b>Discharge Head</b>	Stainless Steel 304, discharge 2" NPT from 35 GPM to 80 GPM series
<b>Motor Adapter</b>	Stainless Steel 304, NEMA standard
<b>Check Valve</b>	Stainless Steel 304
<b>External Shell</b>	Stainless Steel 304 polished
<b>Impellers</b>	Noryl
<b>Diffusers</b>	Polycarbonate
<b>Bearing</b>	Polyacetal
<b>Shaft Coupling</b>	Stainless Steel 304 NEMA Standard
<b>Strainer</b>	Stainless Steel 304
<b>Shaft</b>	Stainless Steel 304
<b>Cable Guard</b>	Stainless Steel 304

Submersible Pumps

## R - 35 GPM

All Stainless Steel Submersible Pumps are designed to pump within the 35 gallons per minute (GPM) range. Sizes are available from 1 to 10 HP. All models are standard with 2" NPT discharge.

### Two Wire Single Phase

Part No.	Model No.	HP	Stages	Volt	A	B	Wt.
6630-053	24100R2	1	6	230	14.1"	16.8"	38
6630-057	24150R2	1 1/2	8	230	16.6"	18.5"	40

### Three Wire Single Phase

Part No.	Model No.	HP	Stages	Volt	A	B	Wt.
6630-054	24100R3	1	6	230	14.1"	13.6"	38
6630-058	24150R3	1 1/2	8	230	16.6"	16.2"	48
6630-065	24200R3	2	10	230	19.0"	16.2"	52
6630-072	24300R3	3	14	230	23.9"	21.4"	75
6630-079	24500R3	5	22	230	35.2"	26.9"	103

### Three Wire Three Phase

Part No.	Model No.	HP	Stages	Volt	A	B	Wt.
6630-062	24150R3Z	1 1/2	8	230	16.6"	13.6"	42
6630-060	24150R3Y	1 1/2	8	460	16.6"	13.6"	37
6630-069	24200R3Z	2	10	230	19.0"	15.4"	62
6630-067	24200R3Y	2	10	460	19.0"	15.4"	48
6630-076	24300R3Z	3	14	230	23.9"	19.8"	60
6630-074	24300R3Y	3	14	460	23.9"	19.8"	54
6630-083	24500R3Z	5	22	230	35.2"	24.2"	79
6630-081	24500R3Y	5	22	460	35.2"	24.2"	74
6630-088	24750R3Z	7 1/2	34	230	49.5"	26.9"	98
6630-086	24750R3Y	7 1/2	34	460	49.5"	26.9"	97
6630-091	241000R3Y	10	43	460	51.9"	30.1"	159

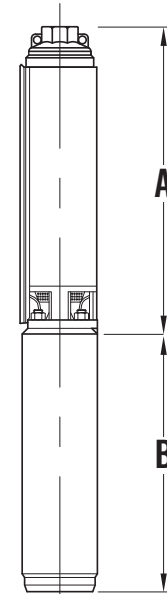

### 4" Stainless Steel Pump Ends

Part No.	Model No.	HP	Wt.
6630-052	24100R	1	8
6630-056	24150R	1 1/2	9
6630-064	24200R	2	11
6630-071	24300R	3	13
6630-078	24500R	5	18
6630-085	24750R	7 1/2	26
6630-090	241000R	10	31

\*\* All three wire pumps are available in three phase by selecting pump end and appropriate motor and starter kit (see pages 121-136).

### Output - in Gallons Per Minute (Depth to Water)

1 HP	PSI	20'	40'	60'	80'	100'	120'	140'
	0			43	39	34	27.5	17.5
	30	38	32	24	15	19		
	50	24	14					

1 1/2 HP	PSI	20'	40'	60'	80'	100'	120'	140'	160'	180'	200'
	0				44	42	38	34	30	24	16
	30		40	37	28	25	22	10			
	50	37	28	25	20	8					

2 HP	PSI	40'	60'	80'	100'	120'	140'	160'	180'	200'	220'	240'	260'
	0				44.3	42.3	41	39	35	30	24	18	12
	30		42	41	39	35	30	21	16	9			
	50	41	39	35	30	21	16	8					

3 HP	PSI	60'	80'	100'	120'	140'	160'	180'	200'	220'	240'	260'	280'	300'	340'	380'
	0						44.5	43.5	42	40	38	35.8	32.2	28	20	10
	30			44	42.5	41	40	38	35	32	26	24	20	14		
	50	42.5	41	40.5	39	36	34	31	27	22	18	13				

FRICITION LOSSES IN RISER PIPE  
HAVE NOT BEEN CALCULATED

# R - 35 GPM

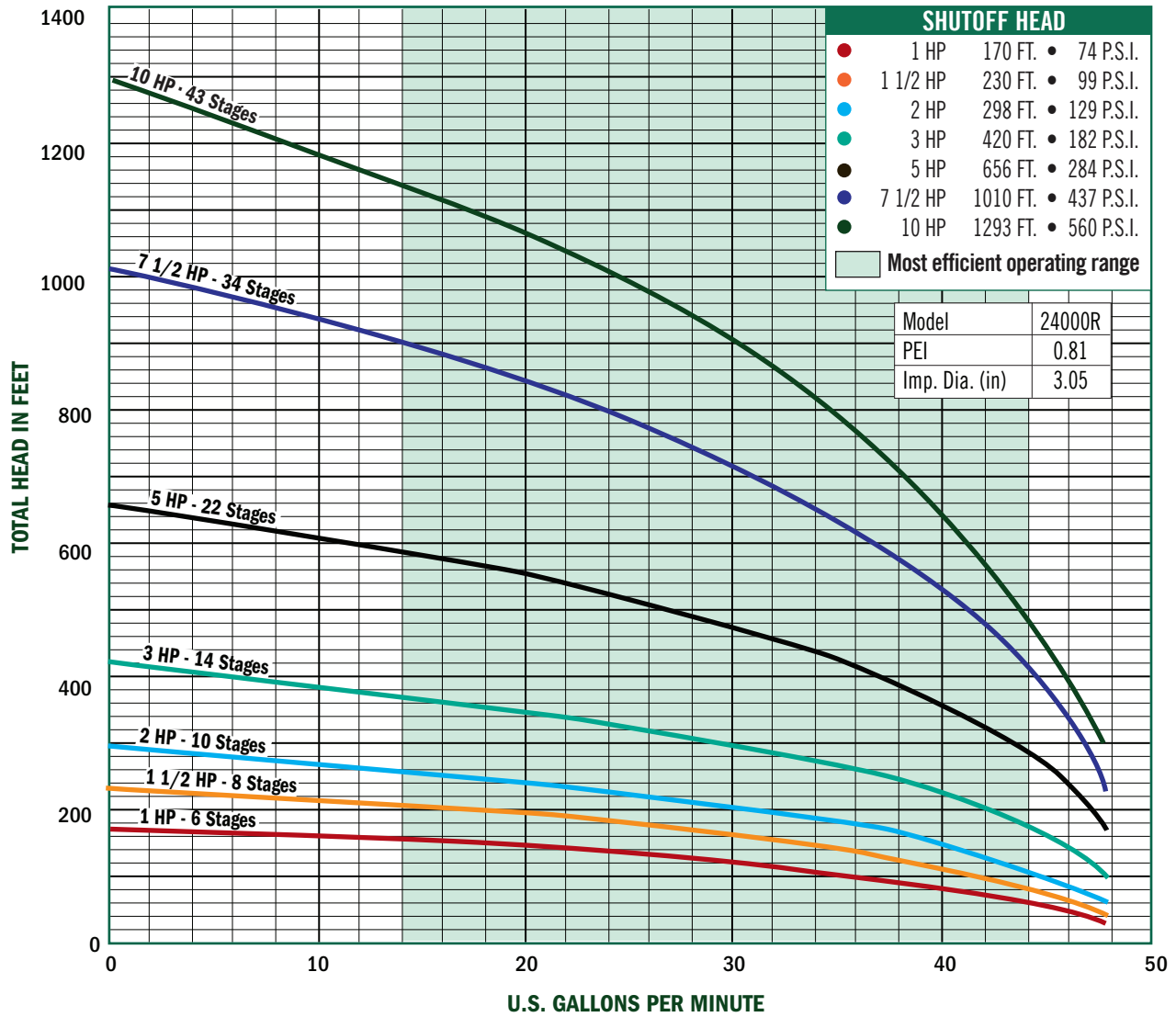

Submersible Pumps

5 HP	PSI	150'	200'	250'	300'	350'	400'	450'	500'	550'	600'
	0			45	43	40	36.5	32	26.8	20	11.8
30			44.5	42	39	32	30	24	16.8		
50	44.5	42.5	39.8	35.8	29.	25					

7 1/2 HP	PSI	300'	350'	400'	450'	500'	550'	600'	650'	700'	750'	800'	850'	900'
	0				41	40	38	35	32.3	29	25	22	17	12
30				41	40	38	35	32.3	29	25	22	17	12	
50	43	42	40	37.8	5	31.3	29	26	21	16	12			

10 HP	PSI	450'	500'	550'	600'	650'	700'	750'	800'	850'	900'	950'	1000'	1050'	1100'	1150'	1200'
	0				43	41	40	38	36	34	31.5	28.5	26	22.3	18.2	14.2	10
30				43.2	41.2	40.3	38.3	37	35	33	30	27.3	24	21	17	13	
50	43.5	42.2	40.5	39.5	37	35.8	33	31	28	25	21	18					

FRICITION LOSSES IN RISER PIPE HAVE NOT BEEN CALCULATED

## G - 40 GPM

All Stainless Steel Submersible Pumps are designed to pump within the 40 gallons per minute (GPM) range. Sizes are available from 1 1/2 to 7 1/2 HP. All models are standard with 2" NPT discharge.

### Two Wire Single Phase

Part No.	Model No.	HP	Stages	Volt	A	B	Wt.
6630-094	24150G2	1 1/2	5	230	12.8"	18.5"	37

### Three Wire Single Phase

Part No.	Model No.	HP	Stages	Volt	A	B	Wt.
6630-095	24150G3	1 1/2	5	230	12.8"	16.2"	48
6630-102	24200G3	2	6	230	14.0"	16.2"	51
6630-109	24300G3	3	8	230	16.5"	21.4"	73
6630-116	24500G3	5	14	230	23.8"	26.9"	99

### Three Wire Three Phase

Part No.	Model No.	HP	Stages	Volt	A	B	Wt.
6630-099	24150G3Z	1 1/2	5	230	12.8"	13.6"	47
6630-097	24150G3Y	1 1/2	5	460	12.8"	13.6"	40
6630-106	24200G3Z	2	6	230	14.0"	15.4"	47
6630-104	24200G3Y	2	6	460	14.0"	15.4"	46
6630-113	24300G3Z	3	8	230	16.5"	19.8"	60
6630-111	24300G3Y	3	8	460	16.5"	19.8"	51
6630-120	24500G3Z	5	14	230	23.8"	24.2"	75
6630-118	24500G3Y	5	14	460	23.8"	24.2"	71
6630-125	24750G3Z	7 1/2	21	230	33.8"	26.9"	93
6630-123	24750G3Y	7 1/2	21	460	33.8"	26.9"	93

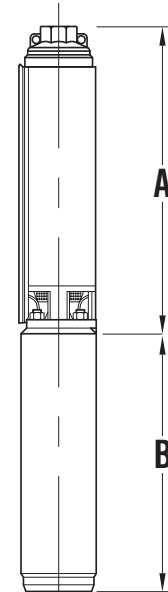

### 4" Stainless Steel Pump Ends

Part No.	Model No.	HP	Wt.
6630-093	24150G	1 1/2	7
6630-101	24200G	2	8
6630-108	24300G	3	9
6630-115	24500G	5	13
6630-122	24750G	7 1/2	18

\*\* All three wire pumps are available in three phase by selecting pump end and appropriate motor and starter kit (see pages 121-136).

### Output - in Gallons Per Minute (Depth to Water)

1 1/2 HP	PSI	20'	30'	40'	50'	60'	70'	80'	90'	100'	120'	140'
	0				65	63	57	54	50	45	32	15
	30			40	31	22	12					
	50	17	12									

2 HP	PSI	20'	30'	40'	50'	60'	70'	80'	90'	100'	120'	140'	160'
	0					66	63	58	56	53	43	34	22
	30	55	52.5	47.5	44	38	34	28	22	12			
	50	37.5	32	27	17.5	12							

3 HP	PSI	20'	30'	40'	50'	60'	70'	80'	90'	100'	120'	140'	160'	180'	200'	240'
	0							66	64	62.5	57	53	43	42	35	10
	30	66	62.5	60	58	57	55	53	43	42	38	31	20	5		
	50	55	52.5	50	47.5	44	41	38	33	27	20					

FRICITION LOSSES IN RISER PIPE  
HAVE NOT BEEN CALCULATED

# G - 40 GPM

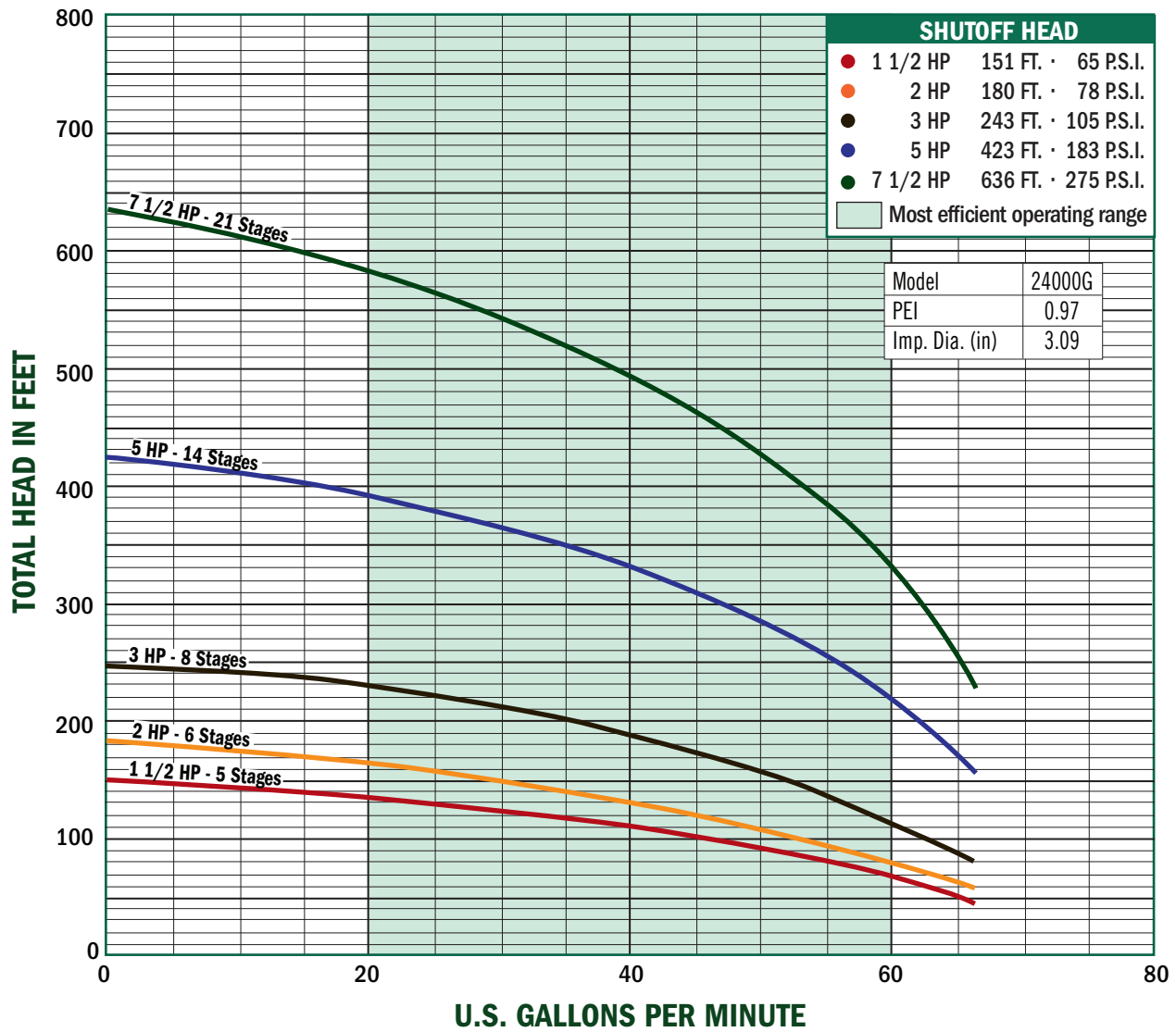

Submersible Pumps

5 HP	PSI	100'	120'	160'	180'	200'	220'	240'	260'	280'	300'	320'	340'	360'	380'	400'
	0					63	58	56	53	50	46	42	37	32	23	16
	30			57	56	52	48	44	40	34	27	18				
	50	60	57	51	47	43	38	33	26	22						

7 1/2 HP	PSI	220'	240'	260'	280'	300'	320'	340'	360'	380'	400'	420'	440'	460'	500'	540'
	0					63	61	58	57	55	53	51	48	45	38	30
	30			59	58	57	53	52	48	46	43	40	37	32	22	
	50	61	57	56	53	52	48	44	42	38	35	31	23			

FRICITION LOSSES IN RISER PIPE HAVE NOT BEEN CALCULATED



## S - 55 GPM

All Stainless Steel Submersible Pumps are designed to pump within the 55 gallons per minute (GPM) range. Sizes are available from 1 1/2 to 10 HP. All models are standard with 2" NPT discharge.

### Two Wire Single Phase

Model No.	Model No.	HP	Stages	Volt	A	B	Wt.
6630-181	24150S2	1 1/2	5	230	17.0"	18.5"	40

### Three Wire Single Phase

Part No.	Model No.	HP	Stages	Volt	A	B	Wt.
6630-182	24150S3	1 1/2	5	230	17.0"	16.2"	44
6630-189	24200S3	2	7	230	21.1"	16.2"	48
6630-196	24300S3	3	9	230	25.2"	21.4"	60
6630-203	24500S3	5	15	230	37.5"	26.9"	95

### Three Wire Three Phase

Part No.	Model No.	HP	Stages	Volt	A	B	Wt.
6630-186	24150S3Z	1 1/2	5	230	17.0"	13.6"	38
6630-184	24150S3Y	1 1/2	5	460	17.0"	13.6"	38
6630-193	24200S3Z	2	7	230	21.1"	15.4"	44
6630-191	24200S3Y	2	7	460	21.1"	15.4"	44
6630-200	24300S3Z	3	9	230	25.2"	19.8"	51
6630-198	24300S3Y	3	9	460	25.2"	19.8"	51
6630-207	24500S3Z	5	15	230	37.5"	24.2"	74
6630-205	24500S3Y	5	15	460	37.5"	24.2"	73
6630-212	24750S3Z	7 1/2	22	230	53.0"	26.9"	97
6630-210	24750S3Y	7 1/2	22	460	53.0"	26.9"	95
6630-215	241000S3Y	10	29	460	67.2"	30.1"	106

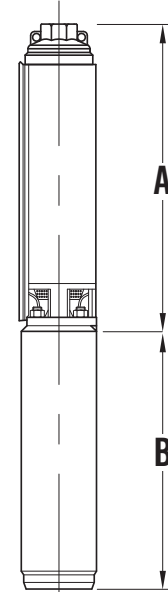

### 4" Stainless Steel Pump Ends

Part No.	Model No.	HP	Wt.
6630-180	24150S	1 1/2	10
6630-188	24200S	2	12
6630-195	24300S	3	14
6630-202	24500S	5	20
6630-209	24750S	7 1/2	28
6630-214	241000S	10	35

\*\* All three wire pumps are available in three phase by selecting pump end and appropriate motor and starter kit (see pages 121-136).

### Output - in Gallons Per Minute (Depth to Water)

1 1/2 HP	PSI	20'	30'	40'	50'	60'	70'	80'	90'	100'	120'
	0			72.5	67.5	65	60	52.5	45	42.5	20
30	47.5	42.5	32.5	20							
50											

2 HP	PSI	10'	20'	30'	40'	50'	60'	70'	80'	90'	100'	120'	140'	160'	180'
	0					77.5	75	72.5	68	67	62.5	60	52	42.5	32
30			62	60	55	52	47	43	37	32	25				
50	48	45	38	35	27	23									

3 HP	PSI	20'	30'	40'	50'	60'	70'	80'	90'	100'	120'	140'	160'	180'	200'	240'
	0						79	76	73	70	68	62.5	57	50	42	34
30				66	62.5	60	57	53	50	46	38	24	17			
50	60	58	53	46	45	40	37	33	27	16						

FRICITION LOSSES IN RISER PIPE HAVE NOT BEEN CALCULATED

# S - 55 GPM

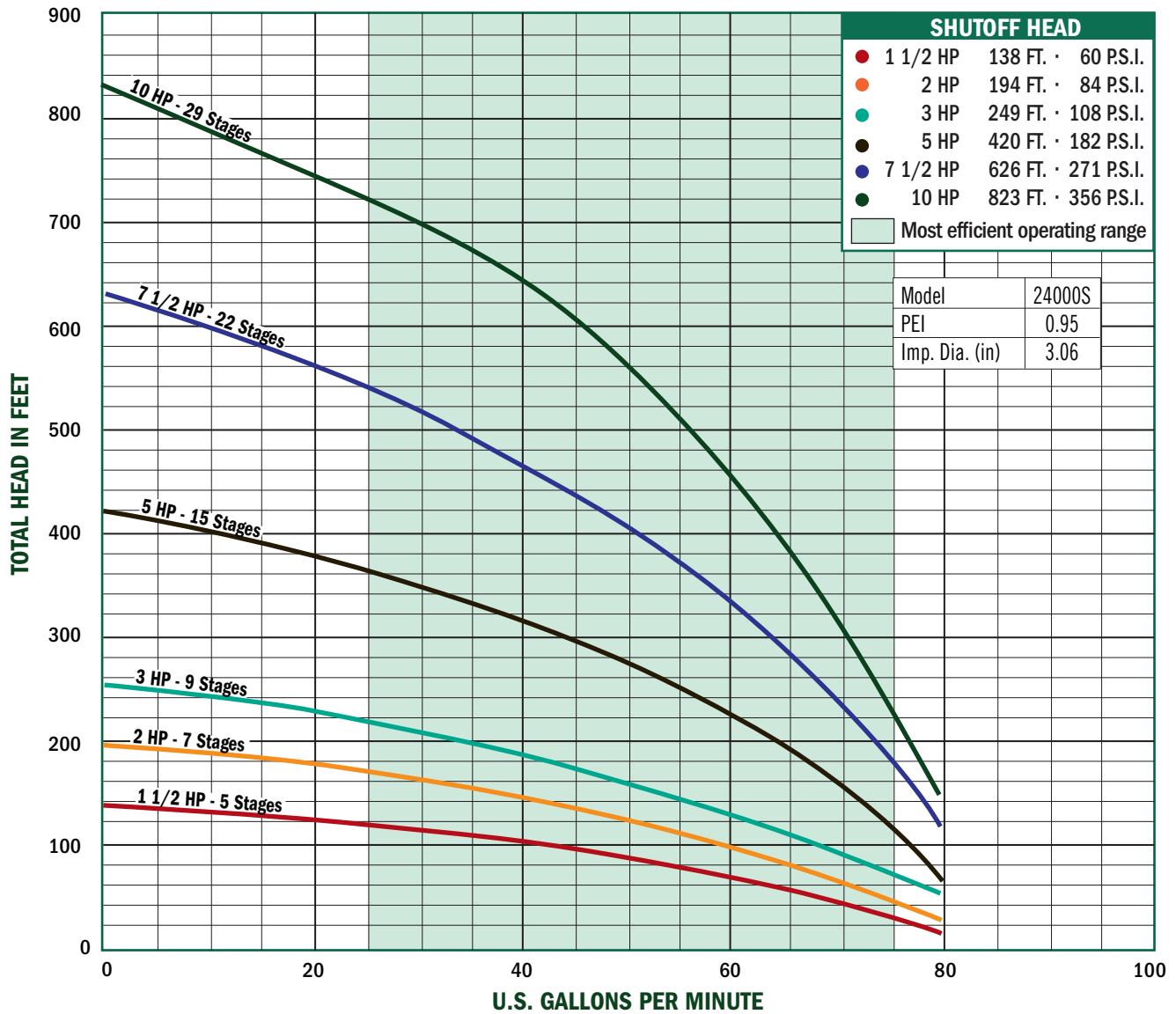

Submersible Pumps

5 HP	PSI	40'	60'	80'	100'	120'	160'	180'	200'	220'	240'	260'	280'	300'	320'	340'	360'	380'
	0				77	75	70	67	65	61	58	53	49	44	38	33	26	18
30		74	72	68	66	58	55	51	47	41	36	29	22					
50	71	68	65	62	58	51	46	41	35	30	22							

7 1/2 HP	PSI	80'	100'	120'	140'	160'	180'	200'	220'	240'	260'	280'	300'	340'	380'	420'	460'	500'	540'
	0					77	75	74	72	70	68	66	64	58	54	47.5	40	33	25
30			74	72.5	71	69	67	65	63	60	57	55	47	42	35	27			
50	74	72	71	68	67	65	62	60	57	55	52	48	42	35					

10 HP	PSI	100'	120'	140'	160'	180'	200'	220'	240'	260'	280'	300'	340'	380'	420'	460'	500'	540'	580'	620'	660'	700'	740'
	0					78	77	76	75	74	73	72	69	67	63	59	55	52	47	41	35	30	20
30				77	76	74	72	71	70	67	66	62	60	57	53	47	43	37	31	23			
50	77	76	75	74	72	71	70	67	66	62	60	57	56	53	50	42	40	33					

FRICITION LOSSES IN RISER PIPE HAVE NOT BEEN CALCULATED

## Q - 60 GPM

All Stainless Steel Submersible Pumps are designed to pump within the 60 gallons per minute (GPM) range. Sizes are available from 1 1/2 to 7 1/2 HP. All models are standard with 2" NPT discharge.

### Two Wire Single Phase

Part No.	Model No.	HP	Stages	Volt	A	B	Wt.
6630-128	24150Q2	1 1/2	4	230	14.9"	18.5"	40

### Three Wire Single Phase

Part No.	Model No.	HP	Stages	Volt	A	B	Wt.
6630-129	24150Q3	1 1/2	4	230	14.9"	16.2"	44
6630-136	24200Q3	2	5	230	16.9"	16.2"	48
6630-143	24300Q3	3	7	230	21.0"	21.4"	60
6630-150	24500Q3	5	11	230	29.2"	26.9"	95

### Three Wire Three Phase

Part No.	Model No.	HP	Stages	Volt	A	B	Wt.
6630-133	24150Q3Z	1 1/2	4	230	14.9"	13.6"	38
6630-131	24150Q3Y	1 1/2	4	460	14.9"	13.6"	38
6630-140	24200Q3Z	2	5	230	16.9"	15.4"	44
6630-138	24200Q3Y	2	5	460	16.9"	15.4"	44
6630-147	24300Q3Z	3	7	230	21.0"	19.8"	51
6630-145	24300Q3Y	3	7	460	21.0"	19.8"	51
6630-154	24500Q3Z	5	11	230	29.2"	24.2"	74
6630-152	24500Q3Y	5	11	460	29.2"	24.2"	73
6630-159	24750Q3Z	7 1/2	17	230	43.0"	26.9"	97
6630-157	24750Q3Y	7 1/2	17	460	43.0"	26.9"	95

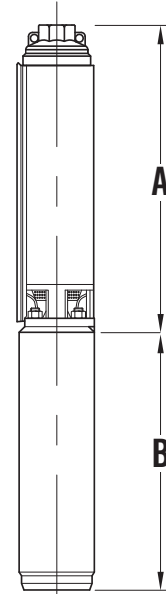

### 4" Stainless Steel Pump Ends

Part No.	Model No.	HP	Wt.
6630-127	24150Q	1 1/2	9
6630-135	24200Q	2	10
6630-142	24300Q	3	12
6630-149	24500Q	5	16
6630-156	24750Q	7 1/2	23

\*\* All three wire pumps are available in three phase by selecting pump end and appropriate motor and starter kit (see pages 121-136).

### Output - in Gallons Per Minute (Depth to Water)

1 1/2 HP	PSI	10'	20'	30'	40'	50'	60'	70'	80'	90'	100'
	0			85	79	74	67	61	53	44	35
	30	53	44	35	18						
	50										

2 HP	PSI	10'	20'	30'	40'	50'	60'	70'	80'	90'	100'	120'
	0				84	82	78	73	67	62	55	39
	30		62	55	47.5	39	28	15				
	50	37	22									

3 HP	PSI	30'	40'	50'	60'	70'	80'	90'	100'	120'	140'	160'	180'
	0					84	81	77	73	66	57	46	33
	30			66	62	57	52	46	40				
	50	55	48	43	37	30							

FRICITION LOSSES IN RISER PIPE  
HAVE NOT BEEN CALCULATED

# Q - 60 GPM

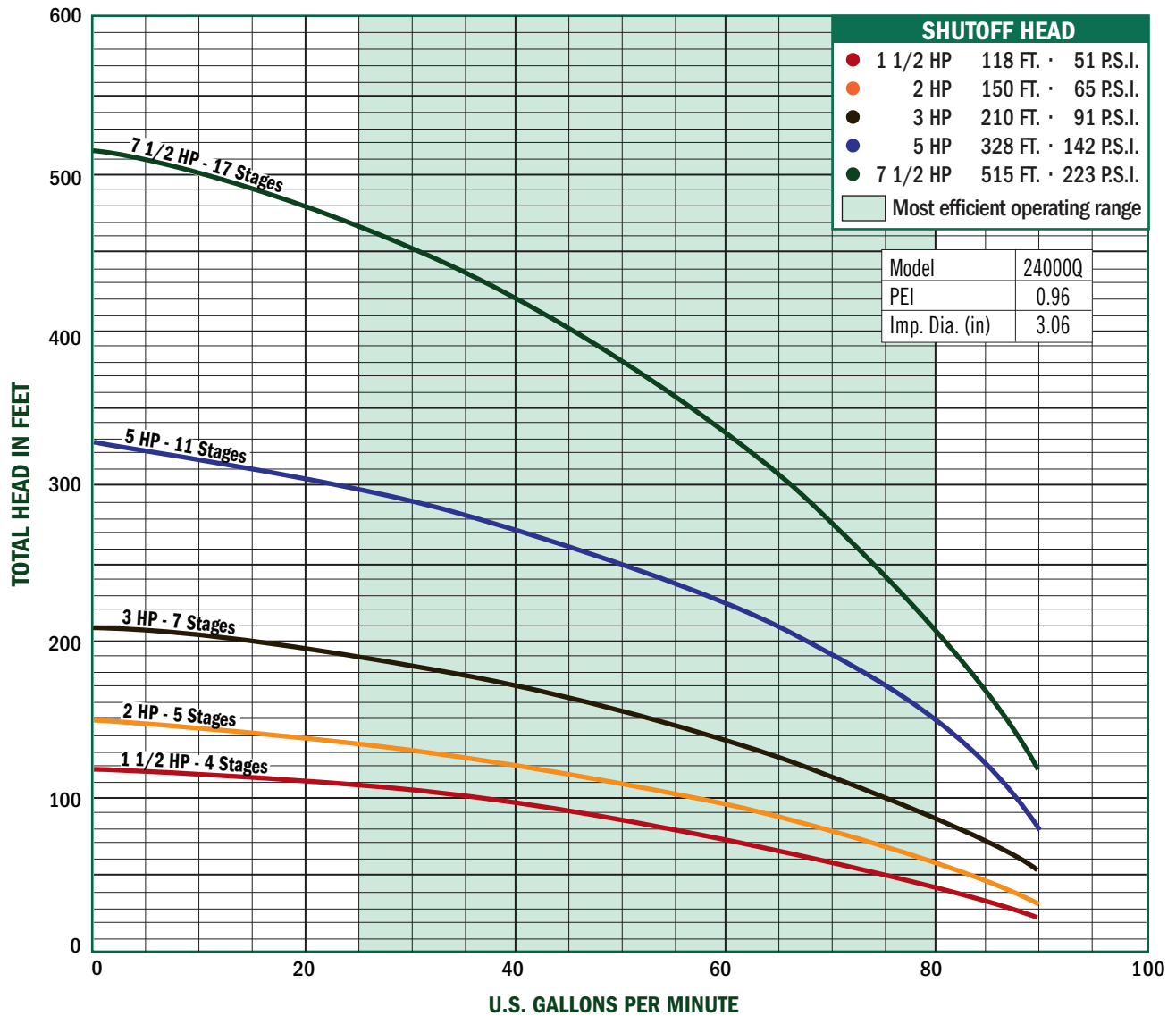

Submersible Pumps

5 HP	PSI	80'	100'	120'	140'	160'	180'	200'	220'	240'	260'	280'
	0					77	72.5	67	60	53	44	28.5
	30			69	66	62.5	50	40	28	16		
	50	69	62	55	47	38	26	15				

7 1/2 HP	PSI	120'	140'	160'	180'	200'	220'	240'	260'	280'	300'	340'	380'	420'
	0					80	78	75	72	69	66	62	50	39
	30				75	73	70.5	67.5	64	60	56	52.5	42	
	50	76	73	69	67	63	57	55	50	46				

FRICITION LOSSES IN RISER PIPE  
HAVE NOT BEEN CALCULATED

## T - 80 GPM

All Stainless Steel Submersible Pumps are designed to pump within the 80 gallons per minute (GPM) range. Sizes are available from 3 to 7 1/2 HP. All models are standard with 2" NPT discharge.

### Three Wire Single Phase

Part No.	Model No.	HP	Stages	Volt	A	B	Wt.
6630-162	24300T3	3	5	230	18.6"	21.4"	58
6630-169	24500T3	5	9	230	29.3"	26.9"	92

### Three Wire Three Phase

Part No.	Model No.	HP	Stages	Volt	A	B	Wt.
6630-166	24300T3Z	3	5	230	18.6"	19.8"	49
6630-164	24300T3Y	3	5	460	18.6"	19.8"	49
6630-173	24500T3Z	5	9	230	29.3"	24.2"	71
6630-171	24500T3Y	5	9	460	29.3"	24.2"	69
6630-178	24750T3Z	7 1/2	14	230	42.6"	26.9"	93
6630-176	24750T3Y	7 1/2	14	460	42.6"	26.9"	91

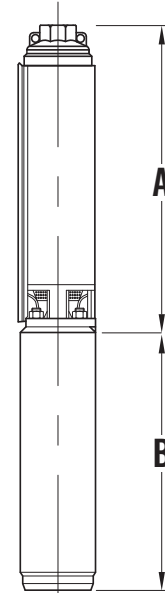

### 4" Stainless Steel Pump Ends

Part No.	Model No.	HP	Wt.
6630-161	24300T	3	10
6630-168	24500T	5	16
6630-175	24750T	7 1/2	22

\*\* All three wire pumps are available in three phase by selecting pump end and appropriate motor and starter kit (see pages 121-136).

### Output - in Gallons Per Minute (Depth to Water)

3 HP	PSI	60'	70'	80'	90'	100'	120'
	0			100	85	73	43
	30	100	58				
	50						

5 HP	PSI	60'	80'	100'	120'	140'	160'	180'	200'	220'	240'
	0					95	83	72	59	45	27
	30			76	65	51	35	20			
	50	75	62	50	32	15					

7 1/2 HP	PSI	120'	140'	160'	180'	200'	220'	240'	260'	280'	300'	320'	340'	360'	380'
	0					96	90	83	75	68	60	52	43	34	25
	30			86	80	72.5	65	56	47	39	27				
	50	80	77	70	63	55	45	36	25						

FRICITION LOSSES IN RISER PIPE  
HAVE NOT BEEN CALCULATED

# T - 80 GPM

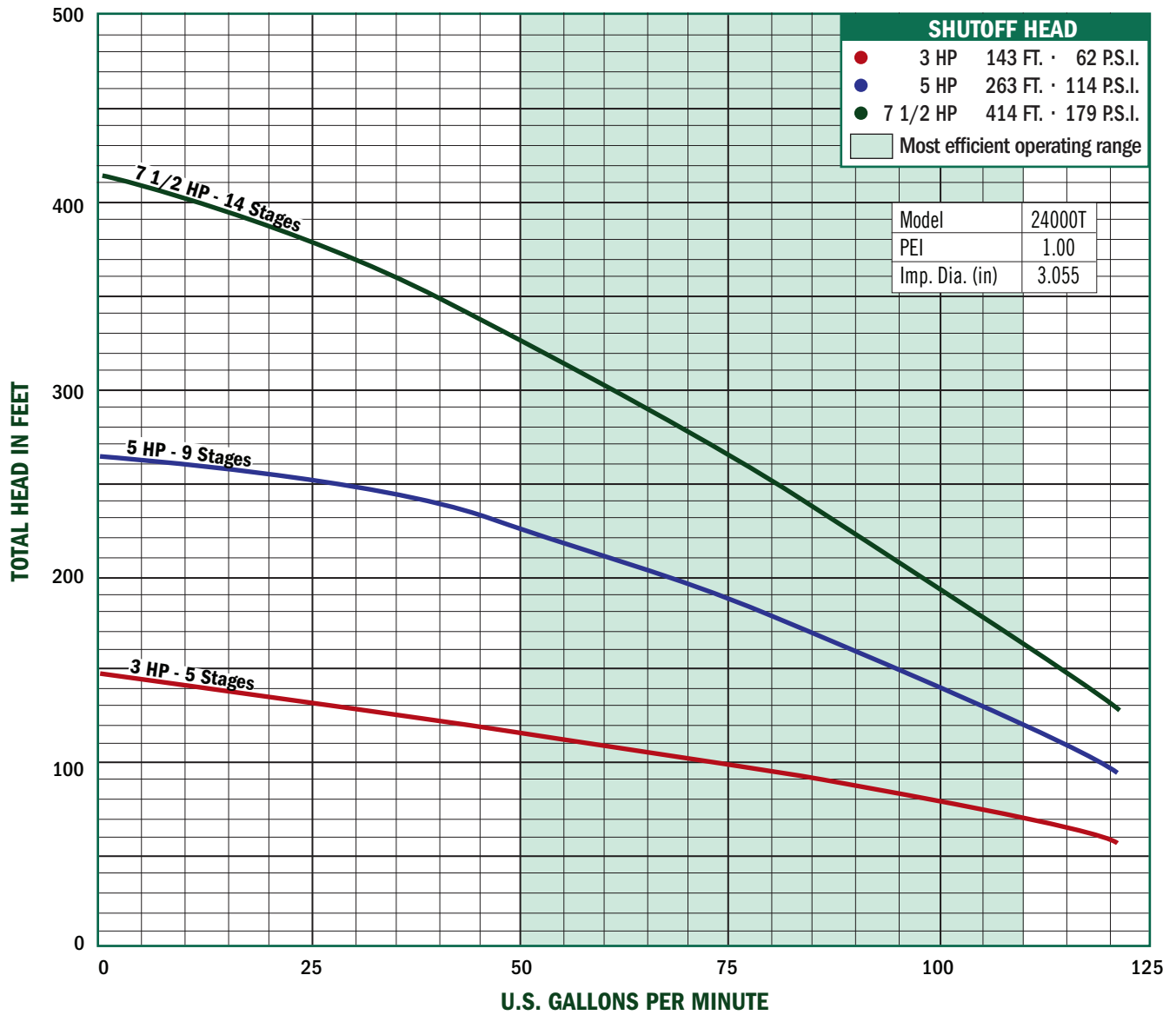

Submersible Pumps

**H SERIES STAINLESS STEEL PUMP ENDS**

	Model	HP	Stages	Discharge	Motor Size	Length (PEO)	Weight (PEO)	List Price
<b>50 GPM H-SERIES 6" PEO</b>	50H05	5	6	3"	6"	24.9"	29	\$ -
	50H07	7½	10	3"	6"	34.4"	40	\$ -
	50H10	10	13	3"	6"	41.6"	51	\$ -
	50H15	15	20	3"	6"	58.2"	73	\$ -
<b>90 GPM H-SERIES 6" PEO</b>	90H03	3	2	3"	4"	16"	14	\$ -
	90H05	5	4	3"	4"	21"	21	\$ -
	90H07	7½	6	3"	6"	25"	27	\$ -
	90H10	10	9	3"	6"	33"	37	\$ -
	90H15	15	13	3"	6"	42"	49	\$ -
	90H20	20	18	3"	6"	54"	65	\$ -
	90H25	25	22	3"	6"	64"	78	\$ -
	90H30	30	26	3"	6"	73"	91	\$ -
90H40	40	30	3"	6"	82"	104	\$ -	
<b>150 GPM H-SERIES 6" PEO</b>	150H05	5	3	3"	4"	22"	22	\$ -
	150H07	7½	4	3"	6"	26"	26	\$ -
	150H10	10	5	3"	6"	30"	31	\$ -
	150H15	15	8	3"	6"	41"	42	\$ -
	150H20	20	11	3"	6"	52"	53	\$ -
	150H25	25	14	3"	6"	60"	63	\$ -
	150H30	30	17	3"	6"	75"	74	\$ -
	150H40	40	23	3"	6"	98"	97	\$ -
	150H50	50	28	3"	6"	117"	116	\$ -
<b>230 GPM H-SERIES 6" PEO</b>	230H05	5	2	3"	4"	20"	20	\$ -
	230H07	7½	3	3"	6"	24"	25	\$ -
	230H10	10	4	3"	6"	28"	30	\$ -
	230H15	15	5	3"	6"	33"	35	\$ -
	230H20	20	7	3"	6"	42"	45	\$ -
	230H25	25	8	3"	6"	46"	50	\$ -
	230H30	30	10	3"	6"	55"	60	\$ -
	230H40	40	13	3"	6"	69"	75	\$ -
	230H50	50	17	3"	6"	86"	95	\$ -
	230H60	60	20	3"	6"	99"	110	\$ -
<b>300 GPM H-SERIES 6" PEO</b>	300H05	5	1	4"	4"	15"	15	\$ -
	300H07	7½	2	4"	6"	20"	20	\$ -
	300H10	10	3	4"	6"	24"	24	\$ -
	300H15	15	4	4"	6"	29"	30	\$ -
	300H20	20	6	4"	6"	37"	40	\$ -
	300H25	25	7	4"	6"	42"	45	\$ -
	300H30	30	9	4"	6"	51"	55	\$ -
	300H40	40	11	4"	6"	60"	65	\$ -
	300H50	50	14	4"	6"	73"	80	\$ -
	300H60	60	17	4"	6"	86"	95	\$ -

**H SERIES STAINLESS STEEL PUMP ENDS**

	Model	HP	Stages	Discharge	Motor Size	Length (PEO)	Weight (PEO)	List Price
<b>400 GPM H-SERIES 8" PEO</b>	400H05	5	1	5"	4"	24"	55	\$ -
	400H07	7½	1	5"	6"	24"	55	\$ -
	400H10	10	2	5"	6"	29"	63	\$ -
	400H15	15	2	5"	6"	29"	63	\$ -
	400H20	20	3	5"	6"	40"	71	\$ -
	400H25	25	4	5"	6"	45"	79	\$ -
	400H30	30	5	5"	6"	50"	87	\$ -
	400H40	40	6	5"	6"	50"	95	\$ -
	400H50	50	7	5"	6"	55"	103	\$ -
	400H60	60	8	5"	6"	60"	114	\$ -
	400H75	75	10	5"	8"	70"	130	\$ -
	400H100	100	13	5"	8"	85"	154	\$ -
<b>500 GPM H-SERIES 8" PEO</b>	500H05	5	1	5"	4"	24"	55	\$ -
	500H07	7½	1	5"	6"	24"	55	\$ -
	500H10	10	1	5"	6"	24"	55	\$ -
	500H15	15	2	5"	6"	29"	63	\$ -
	500H20	20	3	5"	6"	34"	71	\$ -
	500H25	25	3	5"	6"	34"	71	\$ -
	500H30	30	4	5"	6"	40"	79	\$ -
	500H40	40	5	5"	6"	45"	87	\$ -
	500H50	50	6	5"	6"	50"	95	\$ -
	500H60	60	7	5"	6"	55"	406	\$ -
	500H75	75	8	5"	8"	60"	114	\$ -
	500H100	100	11	5"	8"	75"	138	\$ -
	500H125	125	13	5"	8"	85"	153	\$ -
<b>650 GPM H-SERIES 10" PEO</b>	650H15	15	1	5"	6"	26"	67	\$ -
	650H25	25	1	5"	6"	26"	67	\$ -
	650H30	30	2	5"	6"	32"	81	\$ -
	650H40	40	2	5"	6"	32"	81	\$ -
	650H50	50	3	5"	6"	38"	98	\$ -
	650H60	60	3	5"	6"	38"	98	\$ -
	650H75	75	4	5"	8"	44"	112	\$ -
	650H100	100	6	5"	8"	56"	141	\$ -
	650H125	125	7	5"	8"	62"	184	\$ -
	650H150	150	7	5"	8"	62"	184	\$ -
<b>800 GPM H-SERIES 10" PEO</b>	800H20	20	1	5"	6"	26"	67	\$ -
	800H25	25	1	5"	6"	26"	67	\$ -
	800H30	30	1	5"	6"	26"	67	\$ -
	800H40	40	2	5"	6"	32"	82	\$ -
	800H50	50	2	5"	6"	32"	82	\$ -
	800H60	60	3	5"	6"	38"	98	\$ -
	800H75	75	3	5"	8"	38"	98	\$ -
	800H100	100	4	5"	8"	44"	112	\$ -
	800H125	125	5	5"	8"	50"	126	\$ -
	800H150	150	6	5"	8"	56"	141	\$ -



## SP5

PUMP END WITH 6" MOTOR ADAPTER (BOWL OD = 5-1/4")

	Weight	Length	Chrome Shaft List Price	Stainless Shaft List Price
1 STAGE	50	18-1/4"	\$ -	\$ -
2 STAGES	64	22-7/8"	\$ -	\$ -
3 STAGES	78	27-1/2"	\$ -	\$ -
4 STAGES	92	32-1/8"	\$ -	\$ -
5 STAGES	106	36-3/4"	\$ -	\$ -
6 STAGES	120	41-3/8"	\$ -	\$ -
7 STAGES	134	46"	\$ -	\$ -
8 STAGES	148	50-5/8"	\$ -	\$ -
9 STAGES	162	55-1/4"	\$ -	\$ -
10 STAGES	176	59-7/8"	\$ -	\$ -
List Price Adder for 4" Motor Adapter & Coupling				\$ -
List Price Adder for SS Collets / Per Stage				\$ -

## SP5 - OPEN

PUMP END WITH 6" MOTOR ADAPTER (BOWL OD = 5-1/4")

	Weight	Length	Chrome Shaft List Price	Stainless Shaft List Price
1 STAGE	50	17-15/16"	\$ -	\$ -
2 STAGES	64	22-1/4"	\$ -	\$ -
3 STAGES	78	26-9/16"	\$ -	\$ -
4 STAGES	92	30-7/8"	\$ -	\$ -
5 STAGES	106	35-3/16"	\$ -	\$ -
6 STAGES	120	39-1/2"	\$ -	\$ -
7 STAGES	134	43-13/16"	\$ -	\$ -
8 STAGES	148	48-1/8"	\$ -	\$ -
9 STAGES	162	52-7/16"	\$ -	\$ -
10 STAGES	176	56-3/4"	\$ -	\$ -
List Price Adder for 4" Motor Adapter & Coupling				\$ -
List Price Adder For SS Collets / Per Stage				\$ -

## SP6 / SM6

PUMP END WITH 6" MOTOR ADAPTER (BOWL OD = 6")

	Weight	Length	Chrome Shaft List Price	Stainless Shaft List Price
1 STAGE	55	19-1/16"	\$ -	\$ -
2 STAGES	73.5	24"	\$ -	\$ -
3 STAGES	92	28-15/16"	\$ -	\$ -
4 STAGES	110.5	33-7/8"	\$ -	\$ -
5 STAGES	129	38-13/16"	\$ -	\$ -
6 STAGES	147.5	43-3/4"	\$ -	\$ -
7 STAGES	166	48-11/16"	\$ -	\$ -
8 STAGES	184.5	53-5/8"	\$ -	\$ -
9 STAGES	203	58-9/16"	\$ -	\$ -
10 STAGES	221.5	63-1/2"	\$ -	\$ -

List Price Adder for 8" Motor Adapter & Coupling	\$ -
--	------

List Price Adder for SS Collets / Per Stage	\$ -
---	------

## SP6 OPEN

PUMP END WITH 6" MOTOR ADAPTER (BOWL OD = 6")

	Weight	Length	Chrome Shaft List Price	Stainless Shaft List Price
1 STAGE	53	18-15/16"	\$ -	\$ -
2 STAGES	70.7	23-3/4"	\$ -	\$ -
3 STAGES	88.4	28-9/16"	\$ -	\$ -
4 STAGES	106.1	33-3/8"	\$ -	\$ -
5 STAGES	123.8	38-3/16"	\$ -	\$ -
6 STAGES	141.5	43"	\$ -	\$ -
7 STAGES	159.2	47-13/16"	\$ -	\$ -
8 STAGES	176.9	52-5/8"	\$ -	\$ -
9 STAGES	194.6	57-7/16"	\$ -	\$ -
10 STAGES	212.3	62-1/4"	\$ -	\$ -

List Price Adder for 8" Motor Adapter & Coupling	\$ -
--	------

List Price Adder for SS Collets / Per Stage	\$ -
---	------

# SP7

PUMP END WITH 6" MOTOR ADAPTER (BOWL OD = 7-3/16")

	Weight	Length	Chrome Shaft List Price	Stainless Shaft List Price
1 STAGE	100	25-5/16"	\$ -	\$ -
2 STAGES	134	31-11/16"	\$ -	\$ -
3 STAGES	168	38-1/16"	\$ -	\$ -
4 STAGES	202	44-7/16"	\$ -	\$ -
5 STAGES	236	50-13/16"	\$ -	\$ -
6 STAGES	270	57-3/16"	\$ -	\$ -
7 STAGES	304	63-9/16"	\$ -	\$ -

List Price Adder for 8" Motor Adapter & Coupling	\$ -
--	------

List Price Adder for SS Collets / Per Stage	\$ -
---	------

# SK7

PUMP END WITH 6" MOTOR ADAPTER (BOWL OD = 6-9/16")

	Weight	Length	Chrome Shaft List Price	Stainless Shaft List Price
1 STAGE	61	20-7/8"	\$ -	\$ -
2 STAGES	83	27-1/4"	\$ -	\$ -
3 STAGES	105	33-5/8"	\$ -	\$ -
4 STAGES	127	40"	\$ -	\$ -
5 STAGES	149	46-3/8"	\$ -	\$ -
6 STAGES	171	52-3/4"	\$ -	\$ -
7 STAGES	193	59-1/8"	\$ -	\$ -
8 STAGES	215	65-1/2"	\$ -	\$ -
9 STAGES	237	71-7/8"	\$ -	\$ -
10 STAGES	259	78-1/4"	\$ -	\$ -

List Price Adder for 8" Motor Adapter & Coupling	\$ -
--	------

List Price Adder for SS Collets / Per Stage	\$ -
---	------

# SP8

PUMP END WITH 6" MOTOR ADAPTER (BOWL OD = 7-7/8")

	Weight	Length	Chrome Shaft List Price	Stainless Shaft List Price
1 STAGE	100	23-7/8"	\$ -	\$ -
2 STAGES	140	30-1/4"	\$ -	\$ -
3 STAGES	180	36-5/8"	\$ -	\$ -
4 STAGES	220	43"	\$ -	\$ -
5 STAGES	260	49-3/8"	\$ -	\$ -
6 STAGES	300	55-3/4"	\$ -	\$ -
7 STAGES	340	62-1/8"	\$ -	\$ -
8 STAGES	380	68-1/2"	\$ -	\$ -
List Price Adder for 8" Motor Adapter & Coupling				\$ -
List Price Adder for SS Collets / Per Stage				\$ -

# MOTOR SHROUDS

Pump Model	Skirt O.D.	Length	Material	Horsepower	List Price
SP5	7"	36"	PVC	5 to 10	\$ -
	7"	48"	PVC	15 to 30	\$ -
	7"	54"	PVC	40	\$ -
	7"	74"	PVC	50 to 60	\$ -
SP6 / SM6	7"	36"	PVC	5 to 10	\$ -
	7"	48"	PVC	15 to 30	\$ -
	7"	54"	PVC	40	\$ -
	7"	74"	PVC	50 to 60	\$ -
SP7/SP8	8"	36"	PVC	5 to 10	\$ -
	8"	48"	PVC	15 to 30	\$ -
	8"	54"	PVC	40	\$ -
	8"	74"	PVC	50 to 60	\$ -

# STENNER PUMPS®

## What is a peristaltic pump?

A peristaltic pump is a self-priming pump that achieves pumping action by moving a system of rollers against a flexible tube. The pumped fluids (e.g., chemical feeds) are never exposed to the air or to the mechanical moving parts. The roller design prevents siphoning by providing a constant seal on the pumping tube.

## Why Choose A Stenner Pump?

The possibilities are endless with Stenner peristaltic metering pumps. Select from an array of pumps with different operating controls, flow rate outputs, and operating pressure for applications such as oxidation, disinfection, pH control, or for the accurate injection of additives for a manufacturing or industrial

### Markets Served

- Water Conditioning
- Animal Health
- Pool & Spa
- Industrial Process
- Water & Wastewater
- Cooling Towers
- Irrigation
- Car Wash
- Food & Beverage
- Metal Finishing
- Specialty



### Applications

- Sterilization
- pH Control
- Disinfection
- Flocculation
- Iron Control
- Waste Digestion
- Process Water
- Odor Control
- Corrosion Control
- Scale Reduction
- Sanitation



**A.Y. McDonald 89000 Series Self Priming Sprinkler Pumps**

<u>Model</u>	<u>HP</u>	<u>Voltage</u>	<u>Suction</u>	<u>Discharge</u>	<u>Weight</u>	<u>List Price</u>
89100	1	115 / 230	1 1/2"	1 1/2"	59	\$ -
89150	1 1/2	115 / 230	1 1/2"	1 1/2"	63	\$ -
89200	2	230.00	1 1/2"	1 1/2"	64	\$ -



**Features:**

- Up to 85 GPM
- 1 1/2" Inlet & outlet
- Reliable, robust, and tested motor
- Easy to switch between 115V & 230V (Factory preset to 230V)
- 2 HP Sprinkler pump - 230V Only
- 304 Stainless steel motor shaft with wrench flat
- All iron pump housing and seal plate
- 304 Stainless steel insert on impeller
- Stainless steel wear ring between the impeller & diffuser
- Stainless steel bolt hardware connecting pump to motor

**Flow GPM vs. Pressure PSI Curve**

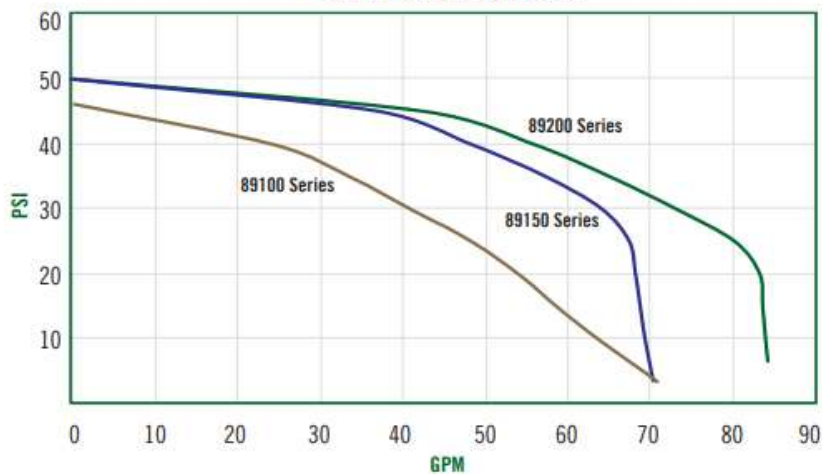

**Performance**

Model No.	HP	Suction Lift - FT.	Capacities in GPM at Discharge Pressure				Max. Shut off PSI
			10	20	30	40	
89100	1	0	63	54	41	24	46.2
		5	61	51	38	19	44
		10	56	46	32		41.9
		15	51	44	28		39.7
		20	43	40	23		38.3
		25	35	34	18		34.8
89150	1 1/2	0	69	68	64	48	49.9
		5	62	61	58	42	46.7
		10	55	53	51	35	45
		15	48	48	46	26	44.2
		20	42	40	39	15	43.8
		25	34	34	30		41.4
89200	2	0	83	83	73	54	50
		5	73	73	69	49	48
		10	57	57	56	39	48
		15	50	50	50	34	43.8
		20	42	42	42	22	45.1
		25	34	34	34		39.4

**DAB WATER TECHNOLOGY E.SYSLINE**

Model	Max Flow	Max PSI	Voltage	Dimensions	List Price
E.Sybox Mini <sup>3</sup>	22 GPM	80 PSI	1 ph 115v	17.4" x 10.7" x 9.5"	\$ -
E.Sybox	32 GPM	92 PSI	1 ph 230v	22.4" x 10.6" x 13.8"	\$ -

The E.Sysline from DAB is a constant pressure system that intergrates with existing systems for an immediate pressure boost. With applications ranging from small houses to multi unit apartment complexes, the E.Sysline has a product that will fit every job.

**Features:**

- \*Adjustable set point from 14 to 85psi
- \*115v & 230v models
- \*Quiet operation (45 dB A)
- \*Wireless connection capabilites with D+Connect
- \*½ gallon integrated pressure tank, precharged at 29psi
- \*Maximum versatilty with 3 installation positions
- \*1¼" inlet and outlet connections
- \*Constant pressure
- \*Self diagnosing
- \*Expandable into booster set wirelessly
- \*Can be used as a shallow well jet pump
- \*Nema 3R rated with additonal E.Sycover



**E.Sybox Accessories**

E.Sywall	Complete wall mounting kit for both E.sybox and Mini <sup>3</sup>	\$ -
E.Sydock	Quick Connect Docking station for E.Sybox	\$ -
E.Sytwin	Quick Connect Docking station to mount 2 E.Sybox's	\$ -
E.Sycover	Outdoor cover for E.Sybox Mini <sup>3</sup> for Nema 3R rating	\$ -
E.Sycover	Outdoor cover for E.Sybox for Nema 3R rating	\$ -
E.Sygrid	Insect Protection Screen Kit for E.Sybox Mini <sup>3</sup>	\$ -
E.Sygrid	Insect Protection Screen Kit for E.Sybox	\$ -



**E.Sydock**



**E.Sytwin**



**E.Sywall**



**E.Sycover**



- **Utility & Pedestal Pumps**
- **Sump & Effluent Pumps**
- **Sewage & Dewatering Pumps**
- **Grinder Pumps**
- **Packaged Systems**
- **Controls**



**A.Y. McDonald 8300 Series Jet Pumps**

Model	HP	Voltage	Suction	Discharge	Max Amps	Switch	Weight	List Price
8350	1/2	<b>115</b> / 230	1 1/4"	1"	10.80	20/40	52	\$ -
8350HP	1/2	<b>115</b> / 230	1 1/4"	1"	10.80	40/60	52	\$ -
8370	3/4	<b>115</b> / <b>230</b>	1 1/4"	1"	7.10	30/50	53	\$ -
8310	1	<b>115</b> / <b>230</b>	1 1/4"	1"	8.30	30/50	63	\$ -
8315	1 1/2	<b>115</b> / <b>230</b>	1 1/4"	1"	10.50	40/60	65	\$ -

\*Factory Voltage Setting Listed in Bold Type



**Features:**

- Up to 32 GPM
- 1" Outlet
- 1 1/4" Inlet
- Reliable, robust, and tested motor
- Easy to switch between 115V & 230V
- 304 Stainless steel motor shaft with wrench flat
- All iron pump housing and seal plate
- 304 Stainless steel insert on plastic impeller
- Stainless steel wear ring between the impeller & diffuser
- Stainless steel bolt hardware connecting pump to motor

**Performance**

Model No.	HP	Suction Lift - FT.	Capacities in GPM at Discharge Pressure					Max. Shut off PSI
			20	30	40	50	60	
8350	1/2	5	17.4	12.6	8.0	2.7	-	58
		10	15.8	11.9	6.6	1.6	-	56
		15	12.9	10.9	5.6	0.8	-	52
		20	10.7	9.4	4.4	0.2	-	51
		25	8.5	8.3	3.6	0.1	-	51
8350HP	1/2	5	10.6	10.6	9.3	6.5	3.4	80
		10	9.4	9.	9.2	6.1	3.1	77
		15	8.2	8.1	8.0	5.3	2.3	74
		20	6.6	6.7	6.7	4.6	1.9	73
		25	4.9	5.0	5.0	4.1	0.0	70
8370	3/4	5	-	22.2	17.1	11.1	6.7	73
		10	-	20.0	15.8	10.8	6.0	70
		15	-	16.5	13.8	9.4	3.7	66
		20	-	13.7	10.9	7.5	1.6	62
		25	-	11.2	10.6	6.6	0.4	61
8310	1	5	-	25.9	21.3	13.8	7.0	70
		10	-	23.3	19.0	12.4	6.0	69
		15	-	19.5	17.1	10.1	3.1	66
		20	-	16.3	15.2	9.6	2.2	63
		25	-	13.4	12.9	7.8	0.2	60
8315	1 1/2	5	-	27.2	26.9	21.8	16.0	87
		10	-	24.1	24.0	20.2	15.2	82
		15	-	20.1	20.1	18.7	13.3	80
		20	-	16.7	16.7	15.9	11.4	75
		25	-	14.3	13.9	13.5	11.3	74

# ELECTRICAL

<b>Section</b>	<b>Page</b>
<b>Motors</b>	
4" Simflo Motors	B-1
4" AY McDonald Motors	B-2
6-10" Hitachi Motors	B-3
6-10" SME Motors	B-4
6-10" AY McDonald Motors	B-5
PVC Motor Shrouds	B-6
<b>Controls / VFD's</b>	
AY McDonald Control Boxes	B-8
Control Box Repair Parts	B-9
Symcom / Littlefuse Relays	B-9
Pressure Switches	B-10
Siemens Control Panels	B-11
Siemens Panel Parts	B-12
Disconnects	B-12
Fuses - 125V & 250V	B-13
Fuses - 600V	B-14
Phase Technologies Phase Converters	B-15
Phase Technologies Essential Series VFD's	B-16
Phase Technologies SD Series VFD's	B-17
Phase Technologies 2XD Series VFD's	B-18
Phase Technologies 1LH Series VFD's	B-19
Phase Technologies 3LH Series VFD's	B-22
Phase Technologies DX Series VFD's	B-26
Phase Technologies Panel Shop Options	B-29
<b>Cable &amp; Acc.</b>	
Cable Selection Chart	
Submersible Cable	B-30
Splice Kits & Butt Connectors	B-30
Tape	B-31
Liquid Tight Conduit & Connectors	B-31
Ground Rods & Clamps	B-31
Tools & Meters	B-32
Badger Flow Meters	B-33

# SIMFLO®

## 4" SIMFLO MOTORS

HP Rating	Leads	Phase	Voltage	Thrust Rating	Length	Diameter	Weight	List Price
½	2 Wire	1	115	300	10"	3.7"	15.0	\$ -
½	2 Wire	1	230	300	10"	3.7"	15.0	\$ -
¾	2 Wire	1	230	300	10.5"	3.7"	17.8	\$ -
1	2 Wire	1	230	650	12"	3.7"	23.3	\$ -
1½	2 Wire	1	230	650	13.5"	3.7"	24.6	\$ -
½	3 Wire	1	230	300	10"	3.7"	15.0	\$ -
¾	3 Wire	1	230	300	10.5"	3.7"	17.8	\$ -
1	3 Wire	1	230	650	12"	3.7"	23.3	\$ -
1½	3 Wire	1	230	650	13.5"	3.7"	24.6	\$ -
2	3 Wire	1	230	650	15"	3.7"	30.8	\$ -
3	3 Wire	1	230	900	17"	3.7"	36.1	\$ -
5	3 Wire	1	230	1500	27"	3.7"	64.5	\$ -
1½	3 Wire	3	230 - 460	650	12"	3.7"	24.0	\$ -
2	3 Wire	3	230 - 460	650	13.5"	3.7"	25.1	\$ -
3	3 Wire	3	230 - 460	900	15"	3.7"	31.2	\$ -
5	3 Wire	3	230 - 460	1500	22"	3.7"	51.5	\$ -
7½	3 Wire	3	230 - 460	1500	27"	3.7"	64.7	\$ -
10	3 Wire	3	460	1500	32"	3.7"	74.6	\$ -



**NOTE: NATIONAL ELECTRICAL CODE REQUIRES THAT SUBMERSIBLE MOTORS BE GROUNDED.**



**4" AY MCDONALD MOTORS**

HP Rating	Leads	Phase	Voltage	Thrust Rating	Length	Diameter	Weight	List Price
½	2 Wire	1	115	500	13.425"	3.662"	21.4	\$ -
½	2 Wire	1	230	500	13.031"	3.662"	21.0	\$ -
¾	2 Wire	1	230	500	13.819"	3.662"	23.2	\$ -
1	2 Wire	1	230	700	16.772"	3.662"	28.9	\$ -
1½	2 Wire	1	230	700	18.543"	3.662"	33.3	\$ -
½	3 Wire	1	115	500	10.472"	3.662"	19.4	\$ -
½	3 Wire	1	230	500	10.472"	3.662"	19.4	\$ -
¾	3 Wire	1	230	500	11.260"	3.662"	21.4	\$ -
1	3 Wire	1	230	700	13.622"	3.662"	27.8	\$ -
1½	3 Wire	1	230	700	16.181"	3.662"	32.5	\$ -
2	3 Wire	1	230	700	16.181"	3.662"	32.7	\$ -
3	3 Wire	1	230	1500	21.417"	3.662"	45.2	\$ -
5	3 Wire	1	230	1500	26.929"	3.662"	59.8	\$ -
1½	3 Wire	3	230 - 460	700	13.622"	3.662"	25.8	\$ -
2	3 Wire	3	230 - 460	700	15.394"	3.662"	30.5	\$ -
3	3 Wire	3	230 - 460	1500	19.843"	3.662"	40.8	\$ -
5	3 Wire	3	230 - 460	1500	24.173"	3.662"	51.9	\$ -
7½	3 Wire	3	230 - 460	1500	26.929"	3.662"	59.8	\$ -
10	3 Wire	3	460	1500	30.079"	3.662"	68.7	\$ -



**NOTE: NATIONAL ELECTRICAL CODE REQUIRES THAT SUBMERSIBLE MOTORS BE GROUNDED.**

**6" HITACHI MOTORS**

Horsepower	Phase	Voltage	Length	Diameter	Weight	List Price
5	1	230	26.97"	5.5"	110	\$ -
7½	1	230	29.92"	5.5"	128	\$ -
10	1	230	29.92"	5.5"	128	\$ -
15	1	230	33.46"	5.5"	148	\$ -
<hr/>						
5	3	230 - 460	22.95"	5.5"	95	\$ -
7½	3	230 - 460	24.80"	5.5"	99	\$ -
10	3	230 - 460	26.97"	5.5"	110	\$ -
15	3	230 - 460	29.92"	5.5"	128	\$ -
20	3	230 - 460	31.50"	5.5"	137	\$ -
25	3	230 - 460	36.22"	5.5"	161	\$ -
30	3	230 - 460	38.19"	5.5"	176	\$ -
40	3	460	40.55"	5.5"	187	\$ -
50	3	460	41.73"	5.5"	198	\$ -
60	3	460	41.73"	5.5"	198	\$ -

**8" X 6" FLANGE HITACHI MOTORS**

50	3	460	45.28"	7.52"	346	\$ -
60	3	460	48.03"	7.52"	401	\$ -

**8" HITACHI MOTORS**

40	3	460	44.09"	7.52"	320	\$ -
50	3	460	46.44"	7.52"	353	\$ -
60	3	460	49.19"	7.52"	408	\$ -
75	3	460	53.15"	7.52"	463	\$ -
100	3	460	58.27"	7.52"	518	\$ -
125	3	460	66.14"	7.52"	595	\$ -
150	3	460	70.08"	7.52"	661	\$ -

**10" HITACHI MOTORS**

200	3	460	69.68"	8.52"	816	\$ -
250	3	460	79.53"	8.52"	948	\$ -

**HITACHI MOTOR ACCESSORIES**

6" Hitachi Motor Leads - #10 AWG (5-30HP)	\$ -
6" Hitachi Motor Leads - #8 AWG (40-60HP)	\$ -
230/460 Volt Hitachi Motor Plug	\$ -



**6" SME MOTORS**

Horsepower	Phase	Voltage	Length	Diameter	Weight	List Price
5	3	230 or 460	28.03"	5.6"	122	\$ -
7½	3	230 or 460	28.03"	5.6"	122	\$ -
10	3	230 or 460	30.00"	5.6"	133	\$ -
15	3	230 or 460	33.35"	5.6"	155	\$ -
20	3	230 or 460	36.89"	5.6"	175	\$ -
25	3	230 or 460	40.43"	5.6"	197	\$ -
30	3	230 or 460	43.78"	5.6"	217	\$ -
40	3	460	49.09"	5.6"	248	\$ -
50	3	460	49.09"	5.6"	248	\$ -
60	3	460	51.77"	5.6"	259	\$ -
70	3	460	54.13"	5.6"	276	\$ -

**8" SME MOTORS**

40	3	460	44.8"	7.6"	375	\$ -
50	3	460	48.7"	7.6"	416	\$ -
60	3	460	51.9"	7.6"	451	\$ -
75	3	460	61.5"	7.6"	536	\$ -
100	3	460	68.0"	7.6"	609	\$ -
125	3	460	71.9"	7.6"	657	\$ -
150	3	460	75.9"	7.6"	701	\$ -
175	3	460	80.2"	7.6"	742	\$ -

**10" SME MOTORS**

150	3	460	56.3"	9.13"	794	\$ -
200	3	460	64.2"	9.13"	1014	\$ -
250	3	460	72.1"	9.13"	1256	\$ -



**SUBMERSIBLE MOTOR ENGINEERING USA**



**6" AY MCDONALD MOTORS**

Horsepower	Phase	Volts	Length	Diameter	Weight	List Price
5	3	230 or 460	23.661"	5.551"	91	\$ -
7½	3	230 or 460	24.843"	5.551"	98	\$ -
10	3	230 or 460	26.023"	5.551"	104	\$ -
15	3	230 or 460	28.779"	5.551"	120	\$ -
20	3	230 or 460	30.944"	5.551"	136	\$ -
25	3	230 or 460	33.897"	5.551"	151	\$ -
30	3	230 or 460	36.258"	5.551"	164	\$ -
40	3	460	41.377"	5.551"	196	\$ -
50	3	460	46.496"	5.551"	225	\$ -
60	3	460	53.582"	5.551"	262	\$ -

**8" AY MCDONALD MOTORS**

50	3	460	46"	7.559"	344	\$ -
60	3	460	50"	7.559"	390	\$ -
75	3	460	53"	7.559"	423	\$ -
100	3	460	63"	7.559"	522	\$ -
125	3	460	72"	7.559"	624	\$ -
150	3	460	81"	7.559"	734	\$ -

**10" AY MCDONALD MOTORS**

200	3	460	81"	9.134"	1102	\$ -
230	3	460	87"	9.134"	1190	\$ -
260	3	460	94"	9.134"	1279	\$ -



**MOTOR SHROUDS**

Pump O.D.	Skirt O.D.	Length	Material	Horsepower	List Price
4"	4.5"	30"	PVC	1-1/2 to 2	\$ -
4"	4.5"	36"	PVC	3 to 5	\$ -
4"	4.5"	42"	PVC	7-1/2 to 10	\$ -
5-1/4"	7"	36"	PVC	5 to 10	\$ -
5-1/4"	7"	48"	PVC	15 to 30	\$ -
5-1/4"	7"	54"	PVC	40	\$ -
5-1/4"	7"	74"	PVC	50 to 60	\$ -
6"	7"	36"	PVC	5 to 10	\$ -
6"	7"	48"	PVC	15 to 30	\$ -
6"	7"	54"	PVC	40	\$ -
6"	7"	74"	PVC	50 to 60	\$ -
7"	8"	36"	PVC	5 - 15	\$ -
7"	8"	48"	PVC	20 - 30	\$ -
7"	8"	54"	PVC	40	\$ -
7"	8"	74"	PVC	50 - 60	\$ -
8"	10"	42"	PVC	5 to 10	\$ -
8"	10"	48"	PVC	15 to 30	\$ -
8"	10"	54"	PVC	40	\$ -
8"	10"	68"	PVC	50	\$ -
8"	10"	74"	PVC	60	\$ -
8"	10"	82"	PVC	75	\$ -

**COMPONENTS**

4" PVC SHROUD HEAD	\$ -
5" PVC SHROUD HEAD	\$ -
6" PVC SHROUD HEAD	\$ -
7" PVC SHROUD HEAD	\$ -
8" PVC SHROUD HEAD	\$ -
SHROUD RIVETS	\$ -
#64 STAINLESS STEEL CLAMP	\$ -
#96 STAINLESS STEEL CLAMP	\$ -
#128 STAINLESS STEEL CLAMP	\$ -



**STAINLESS STEEL CLAMPS**

Mfg Number	Description	Size	Box Quantity	List Price
6308	8	7/16" x 1"	10	\$ -
6310	10	1/2" x 1-1/16"	10	\$ -
6312	12	1/2" x 1-1/4"	10	\$ -
6316	16	11/16" x 1-1/2"	10	\$ -
6320	20	3/4" x 1-3/4"	10	\$ -
6324	24	1" x 2"	10	\$ -
6328	28	1-15/16" x 2-1/2"	10	\$ -
6332	32	1-1/2" x 2-1/2"	10	\$ -
6336	36	1-3/4" x 2-3/4"	10	\$ -
6340	40	2" x 3"	10	\$ -
6352	52	2-3/4" x 3-3/4"	10	\$ -
6364	64	2-1/2" x 4-1/2"	10	\$ -
6372	72	3" x 5"	10	\$ -
6380	80	3-1/2" x 5-1/2"	10	\$ -
6396	96	4-1/2" x 6-1/2"	10	\$ -
63104	104	5" x 7"	10	\$ -
63128	128	6-1/2" x 8-1/2"	10	\$ -
63152	152	8" x 10"	10	\$ -





**AY MCDONALD CONTROL BOXES**

**Standard**

HP	Phase	Voltage	List Price
½	1	115	\$ -
½	1	230	\$ -
¾	1	230	\$ -
1	1	230	\$ -
1½	1	230	\$ -
2	1	230	\$ -
3	1	230	\$ -
5	1	230	\$ -

\*Use Heavy duty pressure switches on 1 ½ hp and above with a standard control box



**Deluxe**

HP	Phase	Voltage	List Price
1½	1	230	\$ -
2	1	230	\$ -
3	1	230	\$ -
5	1	230	\$ -
7½	1	230	\$ -
10	1	230	\$ -
15	1	230	\$ -

\*Deluxe control boxes allow the use of standard pressure switches

**REPAIR PARTS**

MFG NUMBER	DESCRIPTION	LIST PRICE
RD-10-370/440	10 MFD GE RUN CAPACITOR	\$ -
RD-15-370	15 MFD GE RUN CAPACITOR	\$ -
RD-20-370	20 MFD GE RUN CAPACITOR	\$ -
RD-35-370	35 MFD GE RUN CAPACITOR	\$ -
RD-40-370	40 MFD GE RUN CAPACITOR	\$ -
RD-45-370	45 MFD GE RUN CAPACITOR	\$ -

**Run Capacitor Selection Chart**

HP Rating	Capacitors Required		Total MFD Required
1½ HP	1	10 MFD	10
2 HP	1	20 MFD	20
3 HP	1	45 MFD	45
5 HP	2	40 MFD	80
7½ HP	1	45 MFD	45
10 HP	2	35 MFD	70
15 HP	3	45 MFD	135



MFG NUMBER	MFD'S	DESCRIPTION	HORSEPOWER	LIST PRICE
BC-243-125V	243-292	START CAPACITOR	½ HP 115V	\$ -
BC-64M-250V	64-77	START CAPACITOR	½ HP 230V	\$ -
BC-88M-250V	88-108	START CAPACITOR	¾ HP 230V	\$ -
BC-108M-250V	108-130	START CAPACITOR	1 - 2 HP 230V	\$ -
BC-216M-250V	216-259	START CAPACITOR	3 HP 230V	\$ -
BC-270M-330V	270-324	START CAPACITOR	5 - 7½ HP 230V	\$ -
BC-130M-330V	130-156	START CAPACITOR	10 HP 230V	\$ -
BC-161M-330V	161-193	START CAPACITOR	15 HP 230V	\$ -

MFG NUMBER	DESCRIPTION	LIST PRICE
45EG10AGA	30AMP 230V DP CONTACTOR	\$ -
45GG10AGA	40AMP 230V DP CONTACTOR	\$ -

MFG NUMBER	DESCRIPTION	LIST PRICE
111 INSIDER	SYMCOM PUMP PROTECTION RELAY 115V	\$ -
231 INSIDER	SYMCOM PUMP PROTECTION RELAY 230V	\$ -
777-P2	SYMCOM MOTOR SAVER PROGRAMMABLE O/L RELAY	\$ -

**PRESSURE SWITCHES**



Model #	Pressure Setting	Description / Features	List Price
1040	20/40	Standard Water Pump Switch	\$ -
1041	30/50	Standard Water Pump Switch	\$ -
1042	40/60	Standard Water Pump Switch	\$ -
1043	20/40	Pump Switch With Low Cut-Off	\$ -
1044	30/50	Pump Switch With Low Cut-Off	\$ -
1045	40/60	Pump Switch With Low Cut-Off	\$ -
1046	20/40	Heavy Duty Commercial Pump Switch	\$ -
1047	30/50	Heavy Duty Commercial Pump Switch	\$ -
1048	40/60	Heavy Duty Commercial Pump Switch	\$ -
1049	60/80	Heavy Duty Commercial Pump Switch	\$ -



- \*Nema 1 Rated
- \*1/4" FRT Connection
- \*Suitable for all types of pumps
- \*Standard, low pressure cutoff or HD switches available



Model #	Pressure Setting	Description / Features	List Price
FSG-2	20/40	Standard Water Pump Switch	\$ -
FSG-2	30/50	Standard Water Pump Switch	\$ -
FSG-2	40/60	Standard Water Pump Switch	\$ -
FSG-2 (M-1)	20/40	Pump Switch With Manual Cut-Off	\$ -
FSG-2 (M-1)	30/50	Pump Switch With Manual Cut-Off	\$ -
FSG-2 (M-4)	20/40	Pump Switch With Low Cut-Off	\$ -
FSG-2 (M-4)	30/50	Pump Switch With Low Cut-Off	\$ -
GSG-2	20/40	Heavy Duty Commercial Pump Switch	\$ -
GSG-2	30/50	Heavy Duty Commercial Pump Switch	\$ -
GSG-2	40/60	Heavy Duty Commercial Pump Switch	\$ -
GHG-2	40/60	Heavy Duty Commercial Pump Switch (High Pressure)	\$ -
GHG-2	60/80	Heavy Duty Commercial Pump Switch (High Pressure)	\$ -



- \*1/4" FRT Connection
- \*FS Series for use in 1.5hp and smaller
- \*GS Series for use in higher HP applications

NEMA A Type 1 Enclosure		Poles	Cut-Out PSI Range	Differ- ential	Electrical Ratings - Horsepower							
Model No.	Special Features				1 Phase AC		Polyphase AC			Direct Current		
					110V	220V	220V	440V	550V	32V	115V	230V
FSG2	Standard Pump Switch	2	20-65	15-30	1 1/2	2	2	-	-	1/4	-	-
FSG2 (M1)	Manual Cut-Off Lever	2	20-65	15-30	1 1/2	2	2	-	-	1/4	-	-
FSG2 (M4)	Low Pressure Cut-Off Lever	2	20-65	15-30	1 1/2	2	2	-	-	1/4	-	-
GSG2	Heavy Duty Pump Switch	2	20-80	14-43	2	3	5	5	5	1/2	1	1
GHG2	Heavy Duty Pump Switch	2	65-200	25-60	2	3	5	5	5	1/2	1	1



**SIEMENS**  
**ESP200 Control Panel**

NEMA Size	Max HP	Overload Range	Fuse Clip Size	MFG Number	List Price
<b>230 Volt</b>					
1	3	5.5 - 22	30	87DUD6LC	\$ -
1	5-7½	10-40	30	87DUE6LC	\$ -
1-3/4	10	10-40	60	87EUE6LC	\$ -
2	15	13-52	60	87FUF6LC	\$ -
2-1/2	20	25-100	100	87GUG6PC	\$ -
3	25-30	50-200	100	87HUG6LC	\$ -

**Slim Line 460 Volt**

1	5-10	5.5 - 22	30	82ADD6FBH	\$ -
2	15-25	13-52	60	82AFF6FDH	\$ -

**460 Volt**

1	5-10	5.5 - 22	30	87DUD6FC	\$ -
1-3/4	15	10-40	30	87EUE6FC	\$ -
2	20-25	13-52	60	87FUF6FC	\$ -
2-1/2	30	25-100	60	87GUG6FC	\$ -
3	40-50	25-100	100	87HUG6FC	\$ -
3-1/2	60-75	50-200	200	87IUH6FC	\$ -
4	100	50-200	200	87JUH6FC	\$ -
5	125-200	55-250	400	87LPU6FH	\$ -
6	250	160-630	600	87MSW6FH	\$ -

- \*Phase Loss Protection
- \*Ambient Insensitive
- \*FLA Adjustment Range
- \*Heaterless Design
- \*Trip Free Design
- \*NEMA Class 10, 20, and 30 Trip Curves

- \*+ or -2% Repeat Trip Accuracy
- \*Manual Reset
- \*-22° F to 159 ° F
- \*Rated for both 50 & 60 Hz
- \*UL Listed File # E22655
- \*CSA Certified File #LR6535

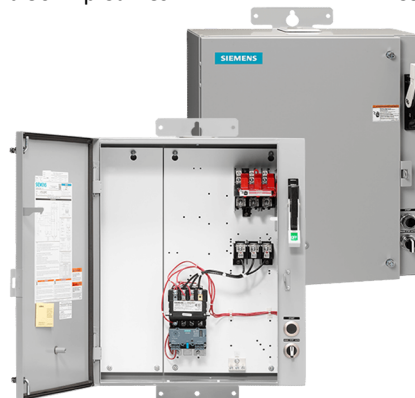

**SIEMENS STARTERS**

MFG Number	NEMA Size	Overload Range	Max HP Rating 230V	Max HP Rating 460V	List Price
14DUD32AC	1	5.5-22 Amp	3	10	\$ -
14EUE32AC	1½	10-40 Amp	10	15	\$ -
14FUF32AC	2	13-52 Amp	15	25	\$ -
14GUG32AC	2½	25-100 Amp	20	30	\$ -



**SIEMENS ESP200 OVERLOAD RELAY**

MFG Number	Overload Range	Max HP Rating 230V	Max HP Rating 460V	List Price
48ATC3S00	3 to 12	2	5	\$ -
48ATD3S00	5.5 to 22	3	10	\$ -
48ATE3S00	10 to 40	10	15	\$ -
48BTF3S00	13 to 52	15	25	\$ -
48BTG3S00	25 to 100	30	50	\$ -
48BTH3S00	50 to 200	50	100	\$ -



**SIEMENS PANEL PARTS**

Mfg Number	Description	List Price
49SASB1	HOA SWITCH STARTER	\$ -
52SB2CAB	HOA SELECTOR	\$ -
52BAK	N/O CONTACT	\$ -
53BAJ	N/C CONTACT	\$ -
52PA8A1	START BUTTON	\$ -
52SA2CABA1P	BLISTER PACK WITH HOA	\$ -
75D73070C	00-2½ 240V/480V COIL	\$ -
75D73251C	3-3½ 240V/480V COIL	\$ -



**Service Disconnects**

Mfg Number	Description	List Price
D211N	30A 240V NEMA 1 FUSED - SCREW IN TYPE	\$ -
GF221N	30A 240V 2P NEMA 1 FUSED	\$ -
GF221NR	30A 240V 2P NEMA 3R FUSED	\$ -
GF222NR	60A 240V 3P NEMA 3R FUSED	\$ -
GF223NR	100A 240V 2P NEMA 3R FUSED	\$ -
GF323NR	100A 240V 3P NEMA 3R FUSED	\$ -
HF361R	30A 600V 3P NEMA 3R FUSED	\$ -
HF362R	60A 600V 3P NEMA 3R FUSED	\$ -
HF363R	100A 600V 3P NEMA 3R FUSED	\$ -
HF364R	200A 600V 3P NEMA 3R FUSED	\$ -



**FUSES**

Model	AMP Rating	HP Range 1 Phase	HP Range 3 Phase	Type	Box Quantity	List Price
GT15	15	½		Plug	4	\$ -
GT20	20	¾		Plug	4	\$ -
GT25	25	1		Plug	4	\$ -
GT30	30	1½		Plug	4	\$ -

**125V**

**250V**

TR-10R	10	1	1½ - 2	Cartridge	10	\$ -
TR-15R	15	1½ - 2	3	Cartridge	10	\$ -
TR-20R	20	3	5	Cartridge	10	\$ -
TR-30R	30	5	7½	Cartridge	10	\$ -
TR-35R	35		10	Cartridge	10	\$ -
TR-40R	40			Cartridge	10	\$ -
TR-45R	45	7½		Cartridge	10	\$ -
TR-60R	60	10	15	Cartridge	10	\$ -
TR-70R	70		20	Cartridge	5	\$ -
TR-80R	80	15		Cartridge	5	\$ -
TR-90R	90		25	Cartridge	5	\$ -
TR-100R	100		30	Cartridge	5	\$ -

- \* AC & DC rated
- \* Time-delay for motor start-ups and transformer inrush currents without nuisance opening
- \* Current-limiting for low peak let-thru current
- \* Easy-to-read label for quick brand recognition and replacement
- \* Metal-embossed date and catalog number for traceability and lasting identification
- \* Fiberglass body provides dimensional stability in harsh industrial settings
- \* High-grade silica filler ensures fast arc quenching and high current limitation
- \* UL Listed / CSA Certified



**FUSES**

Model	AMP Rating	HP Range 1 Phase	HP Range 3 Phase	Type	Box Quantity	List Price
<b><u>600V</u></b>						
TRS-5R	5		1½ - 2	Cartridge	10	\$ -
TRS-7R	7		3	Cartridge	10	\$ -
TRS-10R	10		5	Cartridge	10	\$ -
TRS-15R	15		7½	Cartridge	10	\$ -
TRS-20R	20		10	Cartridge	10	\$ -
TRS-30R	30		15	Cartridge	10	\$ -
TRS-35R	35		20	Cartridge	10	\$ -
TRS-40R	40			Cartridge	10	\$ -
TRS-45R	45		25	Cartridge	10	\$ -
TRS-50R			30	Cartridge	10	\$ -
TRS-60R	60			Cartridge	10	\$ -
TRS-70R	70		40	Cartridge	5	\$ -
TRS-80R	80			Cartridge	5	\$ -
TRS-90R	90		50	Cartridge	5	\$ -
TRS-100R	100			Cartridge	5	\$ -
TRS-110R	110		60	Cartridge	1	\$ -
TRS-125R	125		75	Cartridge	1	\$ -
TRS-150R	150			Cartridge	1	\$ -
TRS-175R	175		100	Cartridge	1	\$ -
TRS-200R	200			Cartridge	1	\$ -
TRS-225R	225		125	Cartridge	1	\$ -



- \* AC & DC rated
- \* Time-delay for motor start-ups and transformer inrush currents without nuisance opening
- \* Current-limiting for low peak let-thru current
- \* Easy-to-read label for quick brand recognition and replacement
- \* Metal-embossed date and catalog number for traceability and lasting identification
- \* Fiberglass body provides dimensional stability in harsh industrial settings
- \* High-grade silica filler ensures fast arc quenching and high current limitation
- \* UL Listed / CSA Certified

**FUSE REDUCERS**

Description	Manufacturer Number	List Price
60A - 30A Fuse Reducer - Cartridge Type	636	\$ -
100A - 30A Fuse Reducer - Cartridge Type	162	\$ -
100A - 60A Fuse Reducer - Cartridge Type	166	\$ -
200A - 60A Fuse Reducer - Cartridge Type	266	\$ -
200A - 100A Fuse Reducer - Cartridge Type	212	\$ -





**PHASE PERFECT - SOLID STATE, DIGITAL PHASE CONVERTER**

**240V Output Phase Converters**

<u>Model Number</u>	<u>HP Rating</u>	<u>Voltage Input</u>	<u>Voltage Output</u>	<u>List Price</u>
PTE007R	7.5	240V 1PH	240V 3PH	Call for Price
PTE010R	10	240V 1PH	240V 3PH	Call for Price
PTE015R	15	240V 1PH	240V 3PH	Call for Price
PTE020R	20	240V 1PH	240V 3PH	Call for Price

**Voltage Doubling Phase Converters**

<u>Model Number</u>	<u>HP Rating</u>	<u>Voltage Input</u>	<u>Voltage Output</u>	<u>List Price</u>
PTE207RQT	7.5	240V 1PH	480V 3PH	Call for Price
PTE210RQT	10	240V 1PH	480V 3PH	Call for Price
PTE215RQT	15	240V 1PH	480V 3PH	Call for Price
PTE220RQT	20	240V 1PH	480V 3PH	Call for Price



**480V Output Phase Converters**

<u>Model Number</u>	<u>HP Rating</u>	<u>Voltage Input</u>	<u>Voltage Output</u>	<u>List Price</u>
PTE407R	7.5	480V 1PH	480V 3PH	Call for Price
PTE410R	10	480V 1PH	480V 3PH	Call for Price
PTE415RQT	15	480V 1PH	480V 3PH	Call for Price
PTE420RQT	20	480V 1PH	480V 3PH	Call for Price

**Increased Efficiency**

- Now 98.7% efficient at full load
- Lower standby losses

**The Best Power Quality**

- Voltage balance within 2%

**Less Noise**

- Compared to rotary phase converters, the Phase Perfect® is 82% quieter

**Improved Starting Capability**

- NEW! PERFECTStart™ - Proprietary control algorithm that prevents overcurrent tripping

**Rugged & Reliable**

- NEMA 1 indoor & NEMA 3R outdoor enclosures available

**Higher Power Ratings**

- 240 V models - now up to 75 HP
- 480 V Models - now up to 100 HP

**PTE Series Features**

- Compact Frame
- NEW! - Voltage Doubling™
- Best in-class value

**PHASE  
PERFECT**  
DIGITAL PHASE CONVERTERS

**PHASE TECHNOLOGIES VFDS**

**Essential Series - 115V / 240V Single Phase Input and Output**

<u>Model</u>	<u>HP</u>	<u>Voltage In</u>	<u>Voltage Out</u>	<u>Input Current</u>	<u>Output Current</u>	<u>List Price</u>
ES3R	1/3 to 2	115v / 230v	115v / 230v	13A	13A	\$ -

\* .5 to 150 PSI Digital Pressure Switch W/ 10' Lead Included

**Additional Panel Shop Options**

<u>Description</u>	<u>List Price</u>
4-20mA Input Board and Transducer	Call For Price & Availability
Overpressure Switch	Call For Price & Availability

**Features and Benefits**

- \*Single phase in, single phase out capabilities
- \*Both 2-wire and 3-wire motor compatibility
- \*Large easy to read graphic display
- \*Easy field servcability
- \*Large wiring area
- \*Auto restart setting
- \*60 psi pre-set digital pressure switch included
- \*Easy setup with perfect pressure
- \*NEMA 3R enclosure with insect guards
- \*122°F (50°C) Rated
- \*Rugged reliability



**ES**  
SERIES



**PHASE TECHNOLOGIES VFDS**

**SD Series - 208V / 240V Single Phase Input - 240V Three Phase Output**

<u>Model</u>	<u>HP</u>	<u>Voltage In</u>	<u>Voltage Out</u>	<u>Input Current</u>	<u>Output Current</u>	<u>List Price</u>
SD002R	½ - 2	240v, 1ph	240v, 3ph	20A	8A	\$ -
SD003R	3	240v, 1ph	240v, 3ph	30A	10A	\$ -
SD005R	5	240v, 1ph	240v, 3ph	42A	18A	\$ -
SD007R	7½	240v, 1ph	240v, 3ph	58A	27A	\$ -
SD010R	10	240v, 1ph	240v, 3ph	69A	33A	\$ -
SD015R	15	240v, 1ph	240v, 3ph	92A	46A	\$ -

\* 0-150 psi Transducer with 15ft lead - included standard with all SD Series models

**SD Series - 480V Single Phase Input - 480V Single Phase Output**

<u>Model</u>	<u>HP</u>	<u>Voltage In</u>	<u>Voltage Out</u>	<u>Input Current</u>	<u>Output Current</u>	<u>List Price</u>
SD405	5	480v, 1ph	480v, 3ph	30A	10A	\$ -
SD407	7½	480v, 1ph	480v, 3ph	37A	13A	\$ -
SD410	10	480v, 1ph	480v, 3ph	42A	18A	\$ -
SD415R	15	480v, 1ph	480v, 3ph	56A	24A	\$ -

\* 0-150 psi Transducer with 15ft lead - included standard with all SD models

**Additional Panel Shop Options**

**Description**

**List Price**

Sine Wave Output Filter

Call For Price & Availability

Strikesorb Surge Protection

Call For Price & Availability



**Features and Benefits**

- \*User Friendly constant pressure setup wizard.
- \*Designed and housed in NEMA 3R enclosure for durability and installation flexibility.
- \*Easily serviceable in the field.
- \*LCD screen shines bright for easy reading, and displays real time information.
- \*Metal door for keypad protection with optional lock for safety.
- \*Able to withstand operating temperatures of up to 122 degrees Fahrenheit.

**SD** SERIES

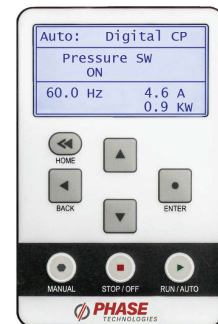

**PHASE TECHNOLOGIES VFDS**

**2XD Series - 240V Single Phase Input - 460V Three Phase Output**

<u>Model</u>	<u>HP</u>	<u>Voltage In</u>	<u>Voltage Out</u>	<u>Input Current</u>	<u>Output Current</u>	<u>List Price</u>
2XD205R	5	240v, 1ph	460v, 3ph	31A	10A	Call for Price
2XD207R	7.5	240v, 1ph	460v, 3ph	52A	13A	Call for Price
2XD210R	10	240v, 1ph	460v, 3ph	64A	18A	Call for Price

\* 0-150 psi Transducer with 15ft lead - included standard with all 2XD models

**Additional Panel Shop Options**

<u>Description</u>	<u>List Price</u>
0-150 PSI Transducer w/ 15' Lead	Call For Price & Availability
0-150 PSI Transducer w/ 25' Lead	Call For Price & Availability
0-150 PSI Transducer w/ 50' Lead	Call For Price & Availability
0-150 PSI Transducer w/ 100' Lead	Call For Price & Availability
Keypad Locking Cover	Call For Price & Availability
HOA Switch and Speed Potentiometer	Call For Price & Availability
Sine Wave Output Filter	Call For Price & Availability
Strikesorb Surge Protector	Call For Price & Availability

**Features and Benefits**

- \***Voltage doubling capabilities** to bring 240V to 480V for better motor efficiency and savings on cable in deep set
- \*Included single event surge protection
- \*Easy set up with Perfect Pressure
- \*NEMA 3R rated outdoor enclosure
- \*Integrated output filter options
- \*Large easy to read graphic display
- \*Metal door for keypad protection with optional lock for safety.



**2XD** SERIES

**PHASE TECHNOLOGIES VFDS**

**1LHE Series - 240V Single Phase Input - 240V Three Phase Output**

<u>Model</u>	<u>HP</u>	<u>Voltage In</u>	<u>Voltage Out</u>	<u>Input Current</u>	<u>Output Current</u>	<u>List Price</u>
1LHE005R	5	240v, 1ph	240v, 3ph	26A	18A	Call for Price
1LHE007R	7.5	240v, 1ph	240v, 3ph	37A	24A	Call for Price
1LHE010R	10	240v, 1ph	240v, 3ph	48A	31A	Call for Price
1LHE015R	15	240v, 1ph	240v, 3ph	72A	46A	Call for Price
1LHE020R	20	240v, 1ph	240v, 3ph	97A	61A	Call for Price

\* See Page B-29 For Additional Panel Shop Options

**1LHE Series - 240V Single Phase Input - 480V Three Phase Output**

<u>Model</u>	<u>HP</u>	<u>Voltage In</u>	<u>Voltage Out</u>	<u>Input Current</u>	<u>Output Current</u>	<u>List Price</u>
1LHE205R	5	240v, 1ph	480v, 3ph	26A	9A	Call for Price
1LHE207R	7.5	240v, 1ph	480v, 3ph	37A	13A	Call for Price
1LHE210R	10	240v, 1ph	480v, 3ph	50A	18A	Call for Price
1LHE215R	15	240v, 1ph	480v, 3ph	67A	24A	Call for Price
1LHE220R	20	240v, 1ph	480v, 3ph	97A	31A	Call for Price
1LHE225R	25	240v, 1ph	480v, 3ph	115A	40A	Call for Price

\* See Page B-29 For Additional Panel Shop Options

**Features and Benefits**

- \***Voltage doubling capabilities** to bring 240V to 480V for better motor efficiency and savings on cable in deep set
- \*Guaranteed IEEE 519 compliant without additional harmonic filters.
- \*Set up constant pressure in minutes.
- \*Large backlit graphic display with intuitive menus.
- \*NEMA 3R enclosure.
- \*Compact and versatile enclosure for ease of installation.
- \*Superior heat rejection and cooling capabilities.
- \*Able to withstand temperatures up to 122° F.



**1LH**  
SERIES



**PHASE TECHNOLOGIES VFDS**

**1LHS Series - 480V Single Phase Input - 480V Three Phase Output**

<u>Model</u>	<u>HP</u>	<u>Voltage In</u>	<u>Voltage Out</u>	<u>Input Current</u>	<u>Output Current</u>	<u>List Price</u>
1LHS420R	20	480v, 1ph	480v, 3ph	48A	31A	Call for Price
1LHS430R	30	480v, 1ph	480v, 3ph	72A	46A	Call for Price
1LHS440R	40	480v, 1ph	480v, 3ph	98A	61A	Call for Price
1LHS450R	50	480v, 1ph	480v, 3ph	121A	77A	Call for Price
1LHS460R	60	480v, 1ph	480v, 3ph	143A	91A	Call for Price
1LHS475R	75	480v, 1ph	480v, 3ph	170A	107A	Call for Price
1LHS4100R	100	480v, 1ph	480v, 3ph	226A	142A	Call for Price

\* See Page B-29 For Additional Panel Shop Options

**Features and Benefits**

- \*Guaranteed IEEE 519 compliant without additional harmonic filters.
- \*Set up constant pressure in minutes.
- \*Large backlit graphic display with intuitive menus.
- \*Phase changing.
- \*NEMA 3R enclosure.
- \*Slim, light design for larger applications.
- \*Superior heat rejection and cooling capabilities.
- \*Able to withstand temperatures up to 122° F.



**1LH**  
SERIES

**SIGNATURE**



**PHASE TECHNOLOGIES VFDS**

**LH Performance Series - 480V Single Phase Input - 480V Three Phase Output**

<u>Model</u>	<u>HP</u>	<u>Voltage In</u>	<u>Voltage Out</u>	<u>Input Current</u>	<u>Output Current</u>	<u>List Price</u>
1LH420R	20	480v, 1ph	480v, 3ph	48A	31A	Call for Price
1LH430R	30	480v, 1ph	480v, 3ph	72A	46A	Call for Price
1LH440R	40	480v, 1ph	480v, 3ph	98A	61A	Call for Price
1LH450R	50	480v, 1ph	480v, 3ph	121A	77A	Call for Price
1LH460R	60	480v, 1ph	480v, 3ph	143A	91A	Call for Price
1LH475R	75	480v, 1ph	480v, 3ph	170A	107A	Call for Price
1LH4100R	100	480v, 1ph	480v, 3ph	226A	142A	Call for Price
1LH4125R	125	480v, 1ph	480v, 3ph	273A	172A	Call for Price

\* See Page B-29 For Additional Panel Shop Options

**Features and Benefits**

- \*Guaranteed IEEE 519 compliant without additional harmonic filters.
- \*Set up constant pressure in minutes.
- \*Large backlit graphic display with intuitive menus.
- \*Phase changing.
- \*NEMA 3R enclosure.
- \*Large enclosure with ample space for additional options.
- \*Superior heat rejection and cooling capabilities.
- \* **AUXPOWER™** can be added to run pivot and pump system in one unit.



**1LH**  
SERIES

**PERFORMANCE**



**PHASE TECHNOLOGIES VFDS**

**3LH Series - 240V Three Phase Input - 240V Three Phase Output**

<u>Model</u>	<u>HP</u>	<u>Voltage In</u>	<u>Voltage Out</u>	<u>Input Current</u>	<u>Output Current</u>	<u>List Price</u>
3LHE005R	5	240v, 3ph	240v, 3ph	18A	18A	Call for Price
3LHE007R	7.5	240v, 3ph	240v, 3ph	24A	24A	Call for Price
3LHE010R	10	240v, 3ph	240v, 3ph	31A	31A	Call for Price
3LHE015R	15	240v, 3ph	240v, 3ph	46A	46A	Call for Price
3LHE020R	20	240v, 3ph	240v, 3ph	61A	61A	Call for Price
3LHE025R	25	240v, 3ph	240v, 3ph	75A	75A	Call for Price
3LHE030R	30	240v, 3ph	240v, 3ph	91A	91A	Call for Price

**3LHE - 240V Three Phase Input - 480V Three Phase Output**

<u>Model</u>	<u>HP</u>	<u>Voltage In</u>	<u>Voltage Out</u>	<u>Input Current</u>	<u>Output Current</u>	<u>List Price</u>
3LHE205R	5	240v, 3ph	480v, 3ph	18A	9A	Call for Price
3LHE207R	7.5	240v, 3ph	480v, 3ph	24A	13A	Call for Price
3LHE210R	10	240v, 3ph	480v, 3ph	30A	18A	Call for Price
3LHE215R	15	240v, 3ph	480v, 3ph	46A	24A	Call for Price
3LHE220R	20	240v, 3ph	480v, 3ph	61A	31A	Call for Price
3LHE225R	25	240v, 3ph	480v, 3ph	77A	38A	Call for Price

\* See Page B-29 For Additional Panel Shop Options

**Features and Benefits**

- \***Voltage doubling capabilities** to bring 240V to 480V for better motor efficiency and savings on cable in deep set
- \*Guaranteed IEEE 519 compliant without additional harmonic filters.
- \*Set up constant pressure in minutes.
- \*Large backlit graphic display with intuitive menus.
- \* Voltage doubling eliminates need for transformer.
- \*NEMA 3R enclosure.
- \*Compact and versatile enclosure for ease of installation.
- \*Superior heat rejection and cooling capabilities.



**3LH**  
SERIES





**PHASE TECHNOLOGIES VFDS**

**3LHE Series - 480V Three Phase Input - 480V Three Phase Output**

<u>Model</u>	<u>HP</u>	<u>Voltage In</u>	<u>Voltage Out</u>	<u>Input Current</u>	<u>Output Current</u>	<u>List Price</u>
3LHE405R	5	480v, 3ph	480v, 3ph	9A	9A	Call for Price
3LHE407R	7.5	480v, 3ph	480v, 3ph	13A	13A	Call for Price
3LHE410R	10	480v, 3ph	480v, 3ph	18A	18A	Call for Price
3LHE415R	15	480v, 3ph	480v, 3ph	24A	24A	Call for Price
3LHE420R	20	480v, 3ph	480v, 3ph	31A	31A	Call for Price
3LHE425R	25	480v, 3ph	480v, 3ph	38A	38A	Call for Price
3LHE430R	30	480v, 3ph	480v, 3ph	46A	46A	Call for Price
3LHE440R	40	480v, 3ph	480v, 3ph	61A	61A	Call for Price
3LHE450R	50	480v, 3ph	480v, 3ph	77A	77A	Call for Price

\* See Page B-29 For Additional Panel Shop Options

**Features and Benefits**

- \*Guaranteed IEEE 519 compliant without additional harmonic filters.
- \*Set up constant pressure in minutes.
- \*Large backlit graphic display with intuitive menus.
- \*NEMA 3R enclosure.
- \*Compact and versatile enclosure for ease of installation.
- \*Superior heat rejection and cooling capabilities.



**3LH**  
SERIES

**ENTERPRISE**



**PHASE TECHNOLOGIES VFDS**

**3LHS - 240V Three Phase Input - 480V Three Phase Output**

<u>Model</u>	<u>HP</u>	<u>Voltage In</u>	<u>Voltage Out</u>	<u>Input Current</u>	<u>Output Current</u>	<u>List Price</u>
3LHS220R	20	240v, 3ph	480v, 3ph	61A	31A	Call for Price
3LHS230R	30	240v, 3ph	480v, 3ph	91A	46A	Call for Price
3LHS240R	40	240v, 3ph	480v, 3ph	121A	61A	Call for Price
3LHS250R	50	240v, 3ph	480v, 3ph	142A	77A	Call for Price
3LHS260R	60	240v, 3ph	480v, 3ph	172A	91A	Call for Price

**3LHS - 480V Three Phase Input - 480V Three Phase Output**

<u>Model</u>	<u>HP</u>	<u>Voltage In</u>	<u>Voltage Out</u>	<u>Input Current</u>	<u>Output Current</u>	<u>List Price</u>
3LHS420R	20	480v, 3ph	480v, 3ph	31A	31A	Call for Price
3LHS430R	30	480v, 3ph	480v, 3ph	46A	46A	Call for Price
3LHS440R	40	480v, 3ph	480v, 3ph	61A	61A	Call for Price
3LHS450R	50	480v, 3ph	480v, 3ph	77A	77A	Call for Price
3LHS460R	60	480v, 3ph	480v, 3ph	91A	91A	Call for Price
3LHS475R	75	480v, 3ph	480v, 3ph	107A	107A	Call for Price
3LHS4100R	100	480v, 3ph	480v, 3ph	142A	142A	Call for Price
3LHS4125R	125	480v, 3ph	480v, 3ph	172A	172A	Call for Price
3LHS4150R	150	480v, 3ph	480v, 3ph	198A	198A	Call for Price
3LHS4200R	200	480v, 3ph	480v, 3ph	250A	250A	Call for Price

\* See Page B-29 For Additional Panel Shop Options

**Features and Benefits**

- \***Voltage doubling capabilities** to bring 240V to 480V for better motor efficiency and savings on cable in deep set
- \*Guaranteed IEEE 519 compliant without additional harmonic filters.
- \*Set up constant pressure in minutes.
- \*Large backlit graphic display with intuitive menus.
- \*Voltage Doubling
- \*NEMA 3R enclosure.
- \*Slim, light design for larger applications.
- \*Superior heat rejection and cooling capabilities.



**3LH**  
SERIES



**PHASE TECHNOLOGIES VFDS**

**3LH Performance Series - 240V Three Phase Input - 480V Three Phase Output**

<u>Model</u>	<u>HP</u>	<u>Voltage In</u>	<u>Voltage Out</u>	<u>Input Current</u>	<u>Output Current</u>	<u>List Price</u>
3LH220R	20	240v, 3ph	480v, 3ph	61A	31A	Call for Price
3LH230R	30	240v, 3ph	480v, 3ph	91A	46A	Call for Price
3LH240R	40	240v, 3ph	480v, 3ph	121A	61A	Call for Price
3LH250R	50	240v, 3ph	480v, 3ph	142A	77A	Call for Price
3LH260R	60	240v, 3ph	480v, 3ph	172A	91A	Call for Price

\* See Page B-29 For Additional Panel Shop Options

**3LH Performance Series - 480V Three Phase Input - 480V Three Phase Output**

<u>Model</u>	<u>HP</u>	<u>Voltage In</u>	<u>Voltage Out</u>	<u>Input Current</u>	<u>Output Current</u>	<u>List Price</u>
3LH420R	20	480v, 3ph	480v, 3ph	31A	31A	Call for Price
3LH430R	30	480v, 3ph	480v, 3ph	46A	46A	Call for Price
3LH440R	40	480v, 3ph	480v, 3ph	61A	61A	Call for Price
3LH450R	50	480v, 3ph	480v, 3ph	77A	77A	Call for Price
3LH460R	60	480v, 3ph	480v, 3ph	91A	91A	Call for Price
3LH475R	75	480v, 3ph	480v, 3ph	107A	107A	Call for Price
3LH4100R	100	480v, 3ph	480v, 3ph	142A	142A	Call for Price
3LH4125R	125	480v, 3ph	480v, 3ph	172A	172A	Call for Price
3LH4150R	150	480v, 3ph	480v, 3ph	198A	198A	Call for Price
3LH4200R	200	480v, 3ph	480v, 3ph	250A	250A	Call for Price
3LH4250R	250	480v, 3ph	480v, 3ph	304A	304A	Call for Price
3LH4300R	300	480v, 3ph	480v, 3ph	362A	362A	Call for Price
3LH4350R	350	480v, 3ph	480v, 3ph	415A	415A	Call for Price
3LH4400R	400	480v, 3ph	480v, 3ph	478A	478A	Call for Price
3LH4450R	450	480v, 3ph	480v, 3ph	515A	515A	Call for Price

\* See Page B-29 For Additional Panel Shop Options

**Features and Benefits**

- \***Voltage doubling capabilities** to bring 240V to 480V for better motor efficiency and savings on cable in deep set
- \*Guaranteed IEEE 519 compliant without additional harmonic filters.
- \*Set up constant pressure in minutes.
- \*Large backlit graphic display with intuitive menus.
- \*Voltage Doubling
- \*NEMA 3R enclosure.
- \*Large enclosure with ample space for additional options.
- \*Superior heat rejection and cooling capabilities.



**3LH**  
SERIES

**PERFORMANCE**

**PHASE TECHNOLOGIES VFDS**

**DXE Series - 240V Three Phase Input - 240V Three Phase Output**

<u>Model</u>	<u>HP</u>	<u>Voltage In</u>	<u>Voltage Out</u>	<u>Input Current</u>	<u>Output Current</u>	<u>List Price</u>
DXE005R	5	240v, 3ph	240v, 3ph	18A	18A	Call for Price
DXE007R	7.5	240v, 3ph	240v, 3ph	24A	24A	Call for Price
DXE010R	10	240v, 3ph	240v, 3ph	31A	31A	Call for Price
DXE015R	15	240v, 3ph	240v, 3ph	46A	46A	Call for Price
DXE020R	20	240v, 3ph	240v, 3ph	61A	61A	Call for Price
DXE025R	25	240v, 3ph	240v, 3ph	75A	75A	Call for Price
DXE030R	30	240v, 3ph	240v, 3ph	91A	91A	Call for Price

\* See Page B-29 For Additional Panel Shop Options

**DXE Series - 480V Three Phase Input - 480V Three Phase Output**

<u>Model</u>	<u>HP</u>	<u>Voltage In</u>	<u>Voltage Out</u>	<u>Input Current</u>	<u>Output Current</u>	<u>List Price</u>
DXE405R	5	480v, 3ph	480v, 3ph	9A	9A	Call for Price
DXE407R	7.5	480v, 3ph	480v, 3ph	13A	13A	Call for Price
DXE410R	10	480v, 3ph	480v, 3ph	18A	18A	Call for Price
DXE415R	15	480v, 3ph	480v, 3ph	24A	24A	Call for Price
DXE420R	20	480v, 3ph	480v, 3ph	31A	31A	Call for Price
DXE425R	25	480v, 3ph	480v, 3ph	38A	38A	Call for Price
DXE430R	30	480v, 3ph	480v, 3ph	46A	46A	Call for Price
DXE440R	40	480v, 3ph	480v, 3ph	61A	61A	Call for Price
DXE450R	50	480v, 3ph	480v, 3ph	77A	77A	Call for Price

\* See Page B-29 For Additional Panel Shop Options

**Features and Benefits**

- \*Three phase six pulse VFD.
- \*Perfect Pressure setup for constant pressure in minutes.
- \*Large backlit display with messages in clear english.
- \*Advanced motor protection & PID control.
- \*Sinewave filter integration.
- \*Smallest enclosure for tight fitting applications.

**DX**  
SERIES

**ENTERPRISE**



**PHASE TECHNOLOGIES VFDS**

**DXS Series - 480V Three Phase Input - 480V Three Phase Output**

<u>Model</u>	<u>HP</u>	<u>Voltage In</u>	<u>Voltage Out</u>	<u>Input Current</u>	<u>Output Current</u>	<u>List Price</u>
DXS420R	20	480v, 3ph	480v, 3ph	31A	31A	Call for Price
DXS430R	30	480v, 3ph	480v, 3ph	46A	46A	Call for Price
DXS440R	40	480v, 3ph	480v, 3ph	61A	61A	Call for Price
DXS450R	50	480v, 3ph	480v, 3ph	77A	77A	Call for Price
DXS460R	60	480v, 3ph	480v, 3ph	91A	91A	Call for Price
DXS475R	75	480v, 3ph	480v, 3ph	107A	107A	Call for Price
DXS4100R	100	480v, 3ph	480v, 3ph	142A	142A	Call for Price
DXS4125R	125	480v, 3ph	480v, 3ph	172A	172A	Call for Price
DXS4150R	150	480v, 3ph	480v, 3ph	198A	198A	Call for Price
DXS4200R	200	480v, 3ph	480v, 3ph	250A	250A	Call for Price

\* See Page B-29 For Additional Panel Shop Options

**Features and Benefits**

- \*Three phase six pulse VFD.
- \*Perfect Pressure setup for constant pressure in minutes.
- \*Large backlit display with messages in clear english.
- \*Advanced motor protection & PID control.
- \*Sinewave filter integration.
- \*Superior heat rejection, able to operate in conditions up to 122° F.
- \*Slim and light panel design.

**DX**  
SERIES

**SIGNATURE**



**PHASE TECHNOLOGIES VFDS**

**DX Performance Series - 480V Three Phase Input - 480V Three Phase Output**

<u>Model</u>	<u>HP</u>	<u>Voltage In</u>	<u>Voltage Out</u>	<u>Input Current</u>	<u>Output Current</u>	<u>List Price</u>
DX420R	20	480v, 3ph	480v, 3ph	31A	31A	Call for Price
DX430R	30	480v, 3ph	480v, 3ph	46A	46A	Call for Price
DX440R	40	480v, 3ph	480v, 3ph	61A	61A	Call for Price
DX450R	50	480v, 3ph	480v, 3ph	77A	77A	Call for Price
DX460R	60	480v, 3ph	480v, 3ph	91A	91A	Call for Price
DX475R	75	480v, 3ph	480v, 3ph	107A	107A	Call for Price
DX4100R	100	480v, 3ph	480v, 3ph	142A	142A	Call for Price
DX4125R	125	480v, 3ph	480v, 3ph	172A	172A	Call for Price
DX4150R	150	480v, 3ph	480v, 3ph	198A	198A	Call for Price
DX4200R	200	480v, 3ph	480v, 3ph	250A	250A	Call for Price
DX4250R	250	480v, 3ph	480v, 3ph	304A	304A	Call for Price
DX4300R	300	480v, 3ph	480v, 3ph	362A	362A	Call for Price
DX4350R	350	480v, 3ph	480v, 3ph	415A	415A	Call for Price
DX4400R	400	480v, 3ph	480v, 3ph	478A	478A	Call for Price
DX4450R	450	480v, 3ph	480v, 3ph	515A	515A	Call for Price

\* See Page B-29 For Additional Panel Shop Options

**Features and Benefits**

- \*Three phase six pulse VFD.
- \*Perfect Pressure setup for constant pressure in minutes.
- \*Large backlit display with messages in clear english.
- \*Advanced motor protection & PID control.
- \*Sinewave filter integration.
- \*Superior heat rejection, able to operate in conditions up to 122° F.
- \*Large enclosure with ample space for additional options.

**DX**  
SERIES

**PERFORMANCE**



**PHASE TECHNOLOGIES VFDS**

**LH & DX Series Additional Panel Shop Options**

<u>Option Code</u>	<u>Description</u>	<u>List</u>
B	MCCB Service Disconnect	Call for Price
H	HOA Switch and Speed Potentiometer	Call for Price
H1	HOA Switch	Call for Price
H2	Speed Potentiometer	Call for Price
O	Sinewave Output Filter	Call for Price
ASPD013	Three Phase Strikesorb Surge Protection	Call for Price
ASPD014	Single Phase Strikesorb Surge Protection	Call for Price
S1	Protac Surge Protection	Call for Price
S00150	0 - 150 PSI Pressure Transducer w/ 15' Lead	Call for Price
S00150-25	0 - 150 PSI Pressure Transducer w/ 25' Lead	Call for Price
S00150-50	0 - 150 PSI Pressure Transducer w/ 50' Lead	Call for Price
S00150-100	0 - 150 PSI Pressure Transducer w/ 100' Lead	Call for Price
PSI SNUB	Pressure Snubber for Transducers	Call for Price
CVR0002	Keypad locking security cover for Enterprise Enclosures	Call for Price
CVR0001	HOA Switch and Speed Pot Security Cover	Call for Price
LEGS	Pad Mount Leg Kit (Drive Specific)	Call for Price

**DX**  
SERIES

**3LH**  
SERIES

**1LH**  
SERIES

SINGLE PHASE															
Motor Rating		75 °C INSULATION - AWG COPPER WIRE SIZE													
Volts	HP	14	12	10	8	6	4	3	2	1	0	00	000	0000	
230 V Single- Phase	115 V 1ph	1/2	100	160	250	390	620	960	1190	1460	1780	2160	2630	3140	3770
		3/4	400	650	1020	1610	2510	3880	4810	5880	7170	8720			
		1	300	480	760	1200	1870	2890	3580	4370	5330	6470	7870	9380	
		1	250	400	630	990	1540	2380	2960	3610	4410	5360	6520	7780	9350
		1.5	190	310	480	770	1200	1870	2320	2850	3500	4280	5240	6300	7620
		2	150	250	390	620	970	1530	1910	2360	2930	3620	4480	5470	6700
		3	120*	190	300	470	750	1190	1490	1850	2320	2890	3610	4470	5550
		5	0	110*	180	280	450	710	890	1110	1390	1740	2170	2680	3330
		7.5	0	0	120*	200	310	490	610	750	930	1140	1410	1720	2100
		10	0	0	0	160*	250	390	490	600	750	930	1160	1430	1760
	15	0	0	0	0	170*	270	340	430	530	660	820	1020	1260	

THREE PHASE																			
Motor Rating		75 °C INSULATION - AWG COPPER WIRE SIZE													MCM COPPER WIRE SIZE				
Volts	HP	14	12	10	8	6	4	3	2	1	0	00	000	0000	250	300	350	400	500
230 V 60 Hz Three- Phase 3- Lead	1/2	930	1490	2350	3700	5760	8910												
	3/4	670	1080	1700	2580	4190	6490	8060	9860										
	1	560	910	1430	2260	3520	5460	6780	8290										
	1.5	420	670	1060	1670	2610	4050	5030	6160	7530	9170								
	2	320	510	810	1280	2010	3130	3890	4770	5860	7170	8780							
	3	240	390	620	990	1540	2400	2980	3660	4480	5470	6690	8020	9680					
	5	140*	230	370	590	920	1430	1790	2190	2690	3290	4030	4850	5870	6650	7560	8460	9220	
	7.5	0	160*	260	420	650	1020	1270	1560	1920	2340	2870	3440	4160	4710	5340	5970	6500	7510
	10	0	0	190*	310	490	760	950	1170	1440	1760	2160	2610	3160	3590	4100	4600	5020	5840
	15	0	0	0	210*	330	520	650	800	980	1200	1470	1780	2150	2440	2780	3110	3400	3940
	20	0	0	0	160*	250*	400	500	610	760	930	1140	1380	1680	1910	2180	2450	2680	3120
	25	0	0	0	0	200*	320	400	500	610	750	920	1120	1360	1540	1760	1980	2160	2520
	30	0	0	0	0	0	260*	330	410	510	620	760	930	1130	1280	1470	1650	1800	2110

THREE PHASE																			
Motor Rating		75 °C INSULATION - AWG COPPER WIRE SIZE													MCM COPPER WIRE SIZE				
Volts	HP	14	12	10	8	6	4	3	2	1	0	00	000	0000	250	300	350	400	500
460 V 60 Hz Three- Phase 3- Lead	1/2	3770	6020	9460															
	3/4	2730	4350	6850															
	1	2300	3670	5770	9070														
	1.5	1700	2710	4270	6730														
	2	1300	2070	3270	5150	8050													
	3	1000	1600	2520	3970	6200													
	5	590	950	1500	2360	3700	5750												
	7.5	420	680	1070	1690	2640	4100	5100	6260	7680									
	10	310	500	790	1250	1960	3050	3800	4680	5750	7050								
	15	0	340*	540	850	1340	2090	2600	3200	3930	4810	5900	7110						
	20	0	0	410	650	1030	1610	2000	2470	3040	3730	4580	5530						
	25	0	0	330*	530	830	1300	1620	1990	2450	3010	3700	4470	5430					
	30	0	0	270*	430	680	1070	1330	1640	2030	2490	3060	3700	4500	5130	5860			
	40	0	0	0	320*	500*	790	980	1210	1490	1830	2250	2710	3290	3730	4250			
	50	0	0	0	410*	640	1030	1300	1620	1990	2450	3010	3700	4470	5430				
	60	0	0	0	0	0	540*	670*	830	1020	1250	1540	1850	2240	2540	2890	3240	3540	4100
	75	0	0	0	0	0	440*	550*	680*	840	1030	1260	1520	1850	2100	2400	2700	2950	3440
	100	0	0	0	0	0	0	0	500*	620*	760*	940	1130	1380	1560	1790	2010	2190	2550
	125	0	0	0	0	0	0	0	0	0	600*	740*	890*	1000	1220	1390	1560	1700	1960
	150	0	0	0	0	0	0	0	0	0	0	630*	760*	920*	1050	1190	1340	1460	1690
175	0	0	0	0	0	0	0	0	0	0	0	670*	810*	930*	1060	1190	1300	1510	
200	0	0	0	0	0	0	0	0	0	0	0	590*	710*	810*	920*	1030	1130	1310	

Lengths with an asterik (\*) meet the N.E.C. ampacity only for single conductor 75 degree Celsius cable.



**FLAT JACKETED HEAVY DUTY CABLE**

Size	Weight Per 1000 Feet	List Price
#14/3 Flat JKTD W-Grnd	151.6	
#12/3 Flat JKTD W-Grnd	199.6	
#10/3 Flat JKTD W-Grnd	268.5	
#8/3 Flat JKTD W-Grnd	383.7	
#6/3 Flat JKTD W-Grnd	531.9	<b>Call</b>
#4/3 Flat JKTD W-Grnd	733.0	<b>For</b>
#2/3 Flat JKTD W-Grnd	1048.3	<b>Price</b>
#0/3 Flat JKTD W-Grnd	1661.5	
#00/3 Flat JKTD W-Grnd	1904.0	
#000/3 Flat JKTD W-Grnd	2493.1	
#0000/3 Flat JKTD W-Grnd	2984.3	
#350 MCM/3 Flat JKTD W-Grnd	4592.3	



- Premium 600 volt cable featuring stranded copper conductors with a moisture resistant PVC insulation
- Conductors are individually colored black, red, and yellow with green ground
- Insulated conductors are assembled parallel in a flat configuration and covered with a tough, black thermoplastic jacket

**TWISTED ROUND JACKETED**

Size	Weight Per 1000 Feet	List Price
#12/3 Round JKTD W-Grnd	159.7	
#10/3 Round JKTD W-Grnd	220.9	<b>Call</b>
#8/3 Round JKTD W-Grnd	322.5	<b>For</b>
#6/3 Round JKTD W-Grnd	464.9	<b>Price</b>
#4/3 Round JKTD W-Grnd	641.7	



- Premium 600 volt cable featuring stranded copper conductors with a moisture resistant PVC insulation
- Conductors are individually colored black, red, and yellow with green ground
- Insulated conductors are assembled parallel in a round configuration and covered with a tough, black thermoplastic jacket

**SPLICE KITS**

Model	Size	Package Quantity	Master Quantity	List Price
A4C	14-12-10	1 Kit	50	\$ -
K8C4	8	1 Kit	50	\$ -
K6C4	6	1 Kit	50	\$ -
K44	4	1 Kit	10	\$ -
K24	2	1 Kit	10	\$ -

**BUTT CONNECTORS**

Model	Size	Package Quantity	Master Quantity	List Price
B1210	12-10	50	500	\$ -
B8	8	25	250	\$ -
B6	6	20	100	\$ -
B4	4	20	100	\$ -
B2	2	10	50	\$ -

**TAPE**

Description	Box Quantity	List Price
3M 1700 ELECTRICAL TAPE *General purpose vinyl tape	10	\$ -
3M SUPER 33 VINYL ELECTRICAL TAPE *General purpose vinyl tape	10	\$ -
3M SUPER 88 VINYL ELECTRICAL TAPE *Premium 8.5mil thick vinyl all weather tape	10	\$ -
LINERLESS RUBBER TAPE ¾" X 30' *Linerless ethylene proplene rubber based tape	10	\$ -
PLYMOUTH RUBBER TAPE ¾" X 22' *Low voltage rubber tape used to primary insolation for splices	10	\$ -
2" CABLE WRAP TAPE - BLACK *General purpose PVC tape	36	\$ -



**METALLIC FLEXIBLE LIQUID TIGHT CONDUIT**

Diameter	Roll Size	List Price
1" METALLIC L/T FLEXIBLE CONDUIT	100'	\$ -
1½" METALLIC L/T FLEXIBLE CONDUIT	50'	\$ -
2" METALLIC L/T FLEXIBLE CONDUIT	50'	\$ -



**LIQUID TIGHT CONDUIT CONNECTORS**

Description	Box Quantity	List Price
1" STRAIGHT STEEL L/T CONNECTOR	10	\$ -
1½" STRAIGHT STEEL L/T CONNECTOR	5	\$ -
2" STRAIGHT STEEL L/T CONNECTOR	5	\$ -
1" 90° STEEL L/T CONNECTOR	10	\$ -
1½" 90° DEGREE STEEL L/T CONNECTOR	5	\$ -
2" 90° DEGREE STEEL L/T CONNECTOR	5	\$ -



**Ground Rods**

Description	Box Quantity	List Price
5/8" x 8' COPPER GROUND ROD	N/A	\$ -
5/8" COPPER GROUND ROD CLAMP	25	\$ -
#6 BARE SOLID COPPER GROUND WIRE	315'	\$ -
#4 BARE SOLID COPPER GROUND WIRE	200'	\$ -



**TOOLS & METERS**

Description	List Price
Simpson Model 372 Ohmeter	\$ -
Case for Simpson 372 Ohmeter	\$ -



400A True RMS AC/DC Clamp Meter	\$ -
400A AC Clamp Meter	\$ -



9" Terminal Crimper / Cutter with Dipped Handles	\$ -
--	------

\*For use on wire from no. 10 to 22AWG. Wire cutter in nose.



**BADGER FLOW METERS**

**M5000 MAG Meter**

Size	GPM Flow Range		Length	List Price
	MIN	MAX		
1/2"	0.09	27	6.7"	
3/4"	0.15	49	6.7"	
1"	0.24	77	8.9"	
1-1/4"	0.39	127	8.9"	
1-1/2"	0.4	199	8.9"	Call
2"	0.94	311	8.9"	For
2-1/2"	1.58	525	11"	Current
3"	2.39	796	11"	Pricing
4"	3.74	1244	11"	
5"	5.84	1946	15.8"	
6"	8.4	2799	15.8"	
8"	15	4976	15.8"	
10"	23.4	7775	19.7"	
12"	33.6	11196	19.7"	

- Available in sizes 0.50...24 in. (15...600 mm)
- Battery powered (10 year life)
- ± 0.4% of measured value ± 2 mm/s accuracy independent of fluid viscosity, density and temperature
- Unaffected by most solids contained in fluids
- Pulsed DC magnetic field for zero point stability
- No pressure loss for low operational costs
- Corrosion resistant liners for long life
- Calibrated in state-of-the art facilities
- Integral and remote signal converter availability
- Optional grounding rings or grounding electrode
- Measurement largely independent of flow profile
- Low-power digital microcontroller (16 bit)
- Simple programming procedure
- Digital and infrared outputs
- Automatic zero-point stability
- Non-volatile programming
- NSF listed
- Data logging
- Available with a hard rubber liner or PTFE liner
- Available with 150-lb and 300-lb flanges



## TANKS

<b>Section</b>	<b>Page</b>
<b>Pressure Tanks</b>	
Zilmet Pressure Tanks	C-1
AO Smith ProMax Plus Pressure Tanks	C-2
AO Smith Glass Lined Pressure Tanks	C-3
<b>Storage Tanks</b>	
Poly Storage Tanks	C-4
Sewage Tanks	C-5
<b>Tank Acc.</b>	
Tank Tees & Accessories	C-6
Pressure Switches	C-7
Float Switches	C-8



## ZILMET DIAPHRAGM TANKS

### HYDRO PLUS SIDE CONNECTION PRESSURE TANKS

MFG Number	Capacity (Gallons)	Diameter	Height	Connection Height	Outlet Size	System Drawdown		List Price
						30/50 PSI	40/60 PSI	
ZHP12	4.8	10.6"	13.7"	In-Line / Bottom	3/4"	1.6	1.4	\$ -
ZHP200F	13.2	15.0"	19.9"	6.0"	1"	4.5	3.9	\$ -
ZHP202	21.1	17.7"	17.7"	5.9"	1	7.2	6.2	\$ -
ZHP203	27.7	19.7"	26.2"	6.5"	1-1/4"	9.5	8.2	\$ -
ZHP204	39.6	19.7"	35.3"	8.5"	1-1/4"	13.5	11.7	\$ -
ZHP250	52.8	23.6"	32.0"	8.9"	1-1/4"	18.0	15.6	\$ -
ZHP251	66.0	24.8"	37.7"	9.6"	1-1/4"	22.5	19.5	\$ -
ZHP302	79.3	24.8"	43.5"	9.6"	1-1/4"	27.0	23.4	\$ -
ZHP351	119.0	29.5"	42.8"	11.4"	1-1/4"	40.6	35.1	\$ -

#### ZILMET SIDE CONNECTION PRESSURE TANK SIZING CHART

GPM	30/50 psig		40/60 psig	
	1 Min.	2 Min.	1 Min.	2 Min.
5	ZHP202	ZHP203	ZHP202	ZHP203
10	ZHP203	ZHP251	ZHP204	ZHP302
12	ZHP204	ZHP302	ZHP250	ZHP302
15	ZHP250	ZHP302	ZHP251	ZHP351
20	ZHP251	ZHP351	ZHP302	ZHP302 (2)
25	ZHP302	ZHP302 (2)	ZHP350	ZHP350 (2)
30	ZHP350	ZHP350 (2)	ZHP351	ZHP351 (2)
35	ZHP351	ZHP351 (2)	ZHP351	ZHP351 (2)

\*Use the above charts to properly size your well tank to prevent excessive wear and tear on your well pump and to reduce energy consumption.  
(2) indicates two tanks required



- Seamless NSF 61 certified low permeability butyl diaphragm creases and channels water directly to outlet, eliminating bacterial growth.
- MIG welding eliminates interior rough spots and sharp edges.
- Low profile tank design with full membrane depth eliminates stretching of diaphragm, providing increased life cycle.
- All diaphragms made by Zilmet specifically for each tanks dimensions.
- Powder coated carbon steel for a longer lasting, more durable tank.
- 5 year warranty on all models.
- Precharged from the factory at 38 psi.
- 150 max. operating pressure.
- 210° F max operating temperature.
- Stainless steel connection.



**PRO MAX PLUS DIAPHRAGM TANKS**

MFG Number	Capacity (Gallons)	Diameter	Height	Connection Height	Outlet Size	System Drawdown (Gallons)		List Price
						30/50 PSI	40/60 PSI	
PMXP-20	20	15-3/8"	32-3/4"	2-1/4"	1"	6.2	5.4	\$ -
PMXP-32	32	15-3/8"	45-1/2"	2-1/4"	1"	9.6	8.4	\$ -
PMXP-36	36	20"	32-5/8"	2-1/4"	1"	11.2	9.7	\$ -
PMXP-52	52	23-3/8"	38-5/8"	2-1/4"	1-1/4"	16.1	14	\$ -
PMXP-65	65	23-3/8"	46-3/5"	2-1/4"	1-1/4"	20	17.5	\$ -
PMXP-86	86	23-3/8"	59"	2-1/4"	1-1/4"	26.7	23.2	\$ -
PMXP-119	119	26"	61-1/4"	2-1/4"	1-1/4"	37	32.3	\$ -

**PROMAX PLUS PRESSURE TANK SIZING CHART**

GPM	30/50 psig.		40/60 psig.	
	1 Min.	2 Min.	1 Min.	2 Min.
5	PMXP-20	PMXP-36	PMXP-20	PMXP-52
10	PMXP-36	PMXP-86	PMXP-52	PMXP-86
12	PMXP-52	PMXP-86	PMXP-52	PMXP-119
15	PMXP-52	PMXP-119	PMXP-65	PMXP-119
20	PMXP-65	PMXP-86(2)	PMXP-86	PMXP-86(2)
25	PMXP-86	PMXP-86(2)	PMXP-119	PMXP-119(2)
30	PMXP-119	PMXP-119(2)	PMXP-119	PMXP-119(2)
35	PMXP-119	PMXP-119(2)	PMXP-86(2)	PMXP-119(2)

\*Use the above chart to properly size your well tank to prevent excessive wear and tear on your well pump and to reduce energy consumption.  
(2) Indicates two tanks required



**ProMax® Plus**

**ProMax® Plus Series**

- 125 PSI Working Pressure
- 304 Stainless Steel Connection
- Butyl Rubber Parabolic Diaphragm - Prevents rubbing on tank wall or rolling over on itself.
- Direct connect diaphragm seal prevents any leakage between water and air chambers.
- Powder coated water chamber provides maximum protection against corrosion.
- Projection welded air valve with "O" ring cap seal for double protection.
- Exclusive no-weld RUST-GUARD® base design assures proper paint coverage in the base area.
- Two-piece construction (on many models) creates only one weld on the tank - Uniweld design.
- Ultra-UV exterior powder finish offers the ultimate protection against the elements.
- 5 Year Limited Warranty

**WATER SYSTEMS**

**An A. O. Smith Company**



### Perma Tank Glass Lined Tanks

MFG Number	Capacity (Gallons)	Diameter (Inches)	Height (Inches)	Weight (Lbs)	List Price
PL-42-T	42	16-1/2	49	71	\$ -
PL-42-S	42	20	35-7/8	81	\$ -
PL-82	82	20	62-1/4	154	\$ -
PL-120	120	24	63	206	\$ -
PL-220	220	30	75		\$ -

- **Maximum Working Pressure 125 PSIG**
- **5-Year Limited Warranty**
- **Anodic Protection**
- **Fused Glass Lining** - The porcelain enamel coating added to the steel tank interior is the plumbing industry's time-tested and trusted system for tank protection. Every tank is made in the U.S.A.
- **Exterior Powder Coat** - Maximum resistance to powerful UV rays. The best exterior protection in the industry.
- **Rolled-Steel Construction** - All glass lined pump tanks feature rolled-steel construction to provide added structural strength.
- **Excellent for Retention Systems or Contact Tanks**
- **Replaces Standard Galvanized or Epoxy Tanks**



# WATER SYSTEMS

An A. O. Smith Company

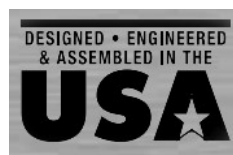



**ABOVE GROUND POLY STORAGE TANKS**

**Snyder Industries Water Storage Tanks**

Size	Color	List Price
500 Gallon Vertical	Black	\$ -
1000 Gallon Vertical	Black	\$ -
1200 Gallon Vertical	Black	\$ -
1600 Gallon Vertical	Black	\$ -
2500 Gallon Vertical	Black	\$ -
3000 Gallon Vertical	Black	\$ -
5000 Gallon Vertical	Black	\$ -

\*NSF Certified, for water storage only.

\*Also available in Mocha and Green

Gallons	Diameter	Height	Opening
500	48"	76"	20"
1000	60"	89"	20"
1200	86"	56.5"	20"
1600	86"	71"	20"
2500	96"	90"	26"
3000	102"	97"	26"
5000	102"	159"	26"

\*Standard with 2" bottom bulkhead and 1½" top bulkhead

**Bulkhead Replacement Fittings**

Size	List Price
¾" Poly Bulkhead Fitting	\$ -
1" Poly Bulkhead Fitting	\$ -
1¼" Poly Bulkhead Fitting	\$ -
1½" Poly Bulkhead Fitting	\$ -
2" Poly Bulkhead Fitting	\$ -
3" Poly Bulkhead Fitting	\$ -
4" Poly Bulkhead Fitting	\$ -



**BELOW GROUND POLY SEPTIC TANKS**

**Snyder Industries Septic Tanks**

Size	Compartment	List Price
500 Gallon Low Profile Septic Tank	Single	\$ -
750 Gallon Septic Tank	Double	\$ -
1000 Gallon Septic Tank	Double	\$ -
1250 Gallon Septic Tank	Double	\$ -
1500 Gallon Septic Tank	Double	\$ -

Gallons	Length	Width	Height	Opening
300	48½"	48½"	49½"	1-20"
750	92"	60"	51"	2-20"
1000	127"	60"	51"	2-20"
1250	157"	60"	51"	2-20"
1500	157"	69"	51"	2-20"

**Snyder Septic Tank Parts**

Size	List Price
20" Septic Tank Lid (Less Screws)	\$ -

Size	Diameter	Height	List Price
Septic Manhole Extension	20"	6"	\$ -
Septic Manhole Extension	20"	15"	\$ -
Septic Manhole Extension	20"	24"	\$ -
Offest Septic Tank Riser	23"	12"	\$ -



**TANK TEE KIT**

**Includes:** (1) Brass tank tee - Long (1) 100# Steel Case Pressure gauge  
 (1) Simmons pressure switch (1) Pressure relief Valve  
 (1) Hose bibb (1) ¼" x 3" SS nipple

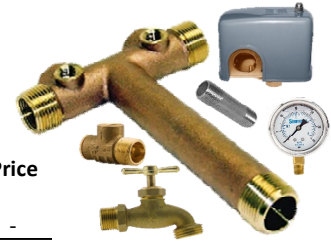

Tank Tee Size	Length	Pressure Gauge	PRV	List Price
1" Tank Tee Kit	14"	¼" x 100 psi	½" 75 PSI	\$ -
1¼" Tank Tee Kit	14"	¼" x 100 psi	¾" 75 PSI	\$ -

**ACCESSORIES**

Type	Diameter	Length	List Price
Brass Tank Tee - Short	1"	4½"	\$ -
Brass Tank Tee - Short with Swivel Nut	1"	4"	\$ -
Brass Tank Tee - Long	1"	14"	\$ -
Brass Tank Tee with Union	1"	11"	\$ -
Brass Tank Tee - Short with Swivel Nut	1¼"	4"	\$ -
Brass Tank Tee - Long	1¼"	14"	\$ -
Brass Tank Tee with Union	1¼"	14"	\$ -
2" Dry Steel Case Pressure Gauge	¼"	100#	\$ -
2" LF Stainless Case Pressure Gauge	¼"	100#	\$ -
2" LF Stainless Case Pressure Gauge	¼"	200#	\$ -
2 1/2" LF Stainless Case Pressure Gauge	¼"	60#	\$ -
2 1/2" LF Stainless Case Pressure Gauge	¼"	100#	\$ -
½" Brass Hose Bibb			\$ -
¾" Brass Hose Bibb			\$ -
½" Brass Hose Bibb (¼ Turn)			\$ -
¾" Brass Hose Bibb (¼ Turn)			\$ -
½" Pressure Relief Valve			\$ -
¾" Pressure Relief Valve			\$ -
¼" X 3" Brass Nipple			\$ -
¼" X 3" Stainless Steel Nipple			\$ -
½" Air Valve			\$ -
¾" Air Valve			\$ -
¾" Brass Bleeder Orifice			\$ -
1" Rubber Bleeder Orifice			\$ -
Deep Well Air Volume Control			\$ -



**PRESSURE SWITCHES**



Model #	Pressure Setting	Description / Features	List Price
1040	20/40	Standard Water Pump Switch	\$ -
1041	30/50	Standard Water Pump Switch	\$ -
1042	40/60	Standard Water Pump Switch	\$ -
1043	20/40	Pump Switch With Low Cut-Off	\$ -
1044	30/50	Pump Switch With Low Cut-Off	\$ -
1045	40/60	Pump Switch With Low Cut-Off	\$ -
1046	20/40	Heavy Duty Commercial Pump Switch	\$ -
1047	30/50	Heavy Duty Commercial Pump Switch	\$ -
1048	40/60	Heavy Duty Commercial Pump Switch	\$ -
1049	60/80	Heavy Duty Commercial Pump Switch	\$ -



- \*Nema 1 Rated
- \*1/4" FRT Connection
- \*Suitable for all types of pumps
- \*Standard, low pressure cutoff or HD switches available



Model #	Pressure Setting	Description / Features	List Price
FSG-2	20/40	Standard Water Pump Switch	\$ -
FSG-2	30/50	Standard Water Pump Switch	\$ -
FSG-2	40/60	Standard Water Pump Switch	\$ -
FSG-2 (M-1)	20/40	Pump Switch With Manual Cut-Off	\$ -
FSG-2 (M-1)	30/50	Pump Switch With Manual Cut-Off	\$ -
FSG-2 (M-4)	20/40	Pump Switch With Low Cut-Off	\$ -
FSG-2 (M-4)	30/50	Pump Switch With Low Cut-Off	\$ -
GSG-2	20/40	Heavy Duty Commercial Pump Switch	\$ -
GSG-2	30/50	Heavy Duty Commercial Pump Switch	\$ -
GSG-2	40/60	Heavy Duty Commercial Pump Switch	\$ -
GHG-2	40/60	Heavy Duty Commercial Pump Switch (High Pressure)	\$ -
GHG-2	60/80	Heavy Duty Commercial Pump Switch (High Pressure)	\$ -



- \*1/4" FRT Connection
- \*FS Series for use in 1.5hp and smaller
- \*GS Series for use in higher HP applications

NEMA A Type 1 Enclosure		Poles	Cut-Out PSI Range	Differ- ential	Electrical Ratings - Horsepower							
Model No.	Special Features				1 Phase AC		Polyphase AC			Direct Current		
					110V	220V	220V	440V	550V	32V	115V	230V
FSG2	Standard Pump Switch	2	20-65	15-30	1 1/2	2	2	-	-	1/4	-	-
FSG2 (M1)	Manual Cut-Off Lever	2	20-65	15-30	1 1/2	2	2	-	-	1/4	-	-
FSG2 (M4)	Low Pressure Cut-Off Lever	2	20-65	15-30	1 1/2	2	2	-	-	1/4	-	-
GSG2	Heavy Duty Pump Switch	2	20-80	14-43	2	3	5	5	5	1/2	1	1
GHG2	Heavy Duty Pump Switch	2	65-200	25-60	2	3	5	5	5	1/2	1	1

**SJE RHOMBUS FLOAT SWITCHES**

MFG Number	Type	Voltage	Cord	Plug	List Price
15PMPU1WP	Up	115	15'	Yes	\$ -
15PMPU2WP	Up	230	15'	Yes	\$ -
15PMPD1WP	Down	115	15'	Yes	\$ -
15PMPD2WP	Down	230	15'	Yes	\$ -
15PMPUWOP	Up	115/230	15'	No	\$ -
15PMPDWOP	Down	115/230	15'	No	\$ -
30PMPUWOP	Up	115/230	30'	No	\$ -
30PMPDWOP	Down	115/230	30'	No	\$ -
Float Switch Cable Weight					\$ -

**Features:**

- \* Heavy-duty contacts
- \* Controls pumps up to 3/4 HP at 120 VAC and 2 HP at 230 VAC
- \* Adjustable pumping range of 7 – 36 inches (18 -91 cm)
- \* Includes standard mounting clamp and boxed packaging
- \* SJE PumpMaster® pump switch on/off position diagram
- \* UL Recognized, CSA Certified



**Options:**

- \* For pump up or pump down applications as specified by part number
- \* With a 120 VAC or 230 VAC piggy-back plug
- \* Without a plug for direct wiring in 120 VAC or 230 VAC applications
- \* In standard cable lengths of 10, 15, 20, or 30 feet (3, 5, 6, or 10 meters) – longer lengths available

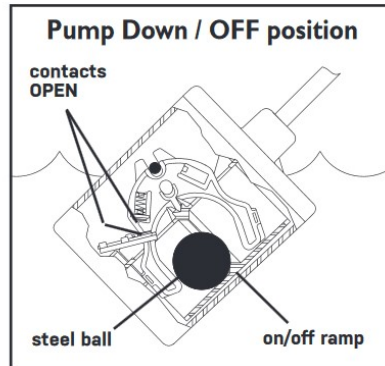
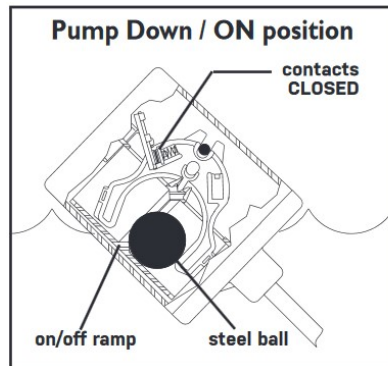

**SQUARE D FLOAT SWITCHES**

List Price

DG2-R Float Switch / Contacts Open On Liquid Rise	\$ -
---	------



## PIPE & FITTINGS

<b>Section</b>	<b>Page</b>
<b>PVC</b>	
Threaded PVC Pipe	D-1
Belled End PVC Pipe & Well Casing	D-2
Jet Stream TiteLoc PVC Casing	D-4
Sch 40 PVC Fittings	D-5
PVC Repair Couplings	D-6
Sch 80 PVC Fittings	D-8
Stainless Steel Clamps	D-9
JC Whitlam PVC Solvents	D-10
JC Whitlam Accessories	D-11
Poly Pipe & Fittings	D-12
PEX Products	D-13
<b>Steel</b>	
Steel Drop Pipe	D-15
Black & Galvanized Steel Fittings	D-16
Black & Galvanized Nipples	D-22
Cast Iron Flanges	D-29
Flange Gaskets	D-29
Grooved Fittings	D-30
Stainless Steel Fittings	D-31
Brass Fittings	D-36
Pipe Thread Compounds	D-37

**Sch 80  
Threaded  
PVC Pipe**

Diameter	Length	Wall Thickness	Outside Diameter	Inside Diameter	Lift Qty (Feet)	List Price
1"	20'	.179"	1.315"	.957"	4000	
1 ¼"	20'	.191"	1.660"	1.278"	2760	
1 ½"	20'	.200"	1.900"	1.500"	1880	<b>Call</b>
2"	20'	.218"	2.375"	1.939"	2800	<b>For</b>
2 ½"	20'	.276"	2.875"	2.323"	1080	<b>Price</b>
3"	20'	.300"	3.500"	2.900"	920	
4"	20'	.340"	4.500"	3.820"	580	

PVC THREADED SCHEDULE 80 PIPE HORSEPOWER RATINGS - DEPTH CHART						
SIZE	MAX HP	RECOMMENDED FITTINGS	PUMPING LIMITATIONS - BASED ON SHUT-OFF SWITCH			TORQUE ARRESTOR USE OVER 150'
			40 PSI	50 PSI	60 PSI	
1"	1.5	EXTRUDED COUPLINGS	610'	590'	570'	USE OVER 150'
1 1/4"	2	EXTRUDED COUPLINGS	475'	455'	435'	USE OVER 150'
1 1/2"	5	STEEL OR BRASS COUPLINGS	435'	415'	395'	USE OVER 150'
2"	7.5	STEEL OR BRASS COUPLINGS	350'	325'	300'	USE OVER 150'

**Sch 120  
Threaded  
PVC Pipe**

Diameter	Length	Wall Thickness	Outside Diameter	Inside Diameter	Lift Qty (Feet)	List Price
1"	20'	.200"	1.315"	.915"	4000	
1 ¼"	20'	.215"	1.660"	1.230"	2760	<b>Call</b>
1 ½"	20'	.225"	1.900"	1.450"	1880	<b>For</b>
2"	20'	.250"	2.375"	1.875"	2800	<b>Price</b>

PVC THREADED SCHEDULE 120 PIPE HORSEPOWER RATINGS - DEPTH CHART						
SIZE	MAX HP	RECOMMENDED FITTINGS	PUMPING LIMITATIONS - BASED ON SHUT-OFF SWITCH			TORQUE ARRESTOR USE OVER 150'
			40 PSI	50 PSI	60 PSI	
1"	1.5	EXTRUDED COUPLINGS	700'	675'	650'	USE OVER 150'
1 1/4"	2	EXTRUDED COUPLINGS	570'	545'	520'	USE OVER 150'
1 1/2"	5	STEEL OR BRASS COUPLINGS	500'	480'	455'	USE OVER 150'
2"	7.5	STEEL OR BRASS COUPLINGS	435'	415'	395'	USE OVER 150'

**THREADED DROP PIPE COUPLINGS**
**Threaded  
Drop Pipe  
Couplings**

Diameter	Galvanized		Black		Stainless Steel	
	Price Each	Box Qty	Price Each	Box Qty	Price Each	Box Qty
1"	\$ -	25	\$ -	25	\$ -	10
1 ¼"	\$ -	25	\$ -	25	\$ -	10
1 ½"	\$ -	25	\$ -	25	\$ -	10
2"	\$ -	25	\$ -	25	\$ -	25
2 ½"	\$ -	20	\$ -	20		
3"	\$ -	15	\$ -	15		
4"	\$ -	10	\$ -	10		



### BELLED END PVC PIPE

	Diameter	Length	Outside Diameter	Inside Diameter	Wall Thickness	Lift Qty (Feet)	List Price
<b>SDR26 160# Belled End PVC Pipe</b>	1 ¼"	20'	1.660"	1.532"	.064"	5620	
	1 ½"	20'	1.900"	1.754"	.073"	4060	
	2"	20'	2.375"	2.193"	.091"	2800	
	2 ½"	20'	2.875"	2.655"	.110"	1740	
	3"	20'	3.500"	3.230"	.135"	1200	<b>Call</b>
	4"	20'+	4.500"	4.154"	.173"	720	<b>For</b>
	4 ½"	20'+	4.950"	4.570"	.190"	480	<b>Price</b>
	5"	20'+	5.563"	5.135"	.214"	420	
	6"	20'+	6.625"	6.115"	.255"	600	
	8"	20'+	8.625"	7.961"	.332"	360	
	10"	20'+	10.750"	9.924"	.413"	220	
<b>SDR21 200# Belled End PVC Pipe</b>	1"	20'	1.315"	1.189"	.063"	8000	
	1 ¼"	20'	1.660"	1.502"	.079"	5620	
	1 ½"	20'	1.900"	1.720"	.090"	4060	
	2"	20'	2.375"	2.149"	.113"	2800	
	2 ½"	20'	2.875"	2.601"	.137"	1740	<b>Call</b>
	3"	20'	3.500"	3.166"	.167"	1200	<b>For</b>
	4"	20'+	4.500"	4.072"	.214"	720	<b>Price</b>
	5"	20'+	5.563"	5.033"	.265"	420	
	6"	20'+	6.625"	5.993"	.316"	600	
	8"	20'+	8.625"	7.805"	.410"	360	
	10"	20'+	10.750"	9.728"	.511"	220	
<b>Sch 40 Belled End PVC Pipe</b>	1"	20'	1.315"	1.049"	.133"	4000	
	1 ¼"	20'	1.660"	1.380"	.140"	5620	
	1 ½"	20'	1.900"	1.610"	.145"	4060	
	2"	20'	2.375"	2.067"	.154"	2800	
	2 ½"	20'	2.875"	2.469"	.203"	1740	<b>Call</b>
	3"	20'	3.500"	3.068"	.216"	1200	<b>For</b>
	4"	20'+	4.500"	4.026"	.237"	720	<b>Price</b>
	4 ½"	20'+	4.950"	4.454"	.248"	480	
	5"	20'+	5.563"	5.047"	.258"	420	
	6"	20'+	6.625"	6.065"	.280"	600	
	8"	20'+	8.625"	7.981"	.322"	360	

### JET STREAM TWENTY+PLUS PVC WELL CASING





### SLOTTED BELLED END PVC PIPE

	Diameter	Slot	Length	C-C Slot Spacing	Number of Rows	Open Area Square Inch	Lift Qty (Feet)	List Price
<b>SDR 26 160#</b>	4"	.035	20'+	.25	4	213	720	
	4 ½"	.035	20'+	.25	4	246	480	
	5"	.020	20'+	.25	4	139	420	
	5"	.035	20'+	.25	4	283	420	
<b>PVC Slotted Belled End Casing</b>	6"	.035	20'+	.25	5	311	600	<b>Call</b>
	8"	.035	20'+	.25	6	418	360	<b>For</b>
	8"	.050	20'+	.25	6	554	360	<b>Price</b>
	8"	.085	20'+	.25	6	834	360	
	10"	.085	20'+	.25	7	1040	220	
<b>SDR 21 200#</b>	4"	.035	20'+	.25	4	120	720	
	5"	.020	20'+	.25	4	134	420	
	5"	.035	20'+	.25	4	269	420	
	6"	.020	20'+	.25	5	158	600	
	6"	.035	20'+	.25	5	290	600	<b>Call</b>
	8"	.035	20'+	.25	6	383	360	<b>For</b>
	8"	.050	20'+	.25	6	507	360	<b>Price</b>
	8"	.085	20'+	.25	6	763	360	
<b>Sch 40 PVC Slotted Belled End Casing</b>	4"	.020	20'+	.25	4	116	720	
	4"	.035	20'+	.25	4	218	720	
	4 ½"	.035	20'+	.25	4	224	480	
	5"	.020	20'+	.25	4	134	420	
	5"	.035	20'+	.25	4	269	420	<b>Call</b>
	6"	.035	20'+	.25	5	311	600	<b>For</b>
	8"	.035	20'+	.25	6	418	360	<b>Price</b>
	8"	.050	20'+	.25	6	554	360	
	8"	.085	20'+	.25	6	834	360	

### JET STREAM TWENTY+PLUS PVC WELL CASING



**JET STREAM TITELOC PVC WELL CASING**

	Diameter	Length	Outside Diameter	Inside Diameter	Wall Thickness	Lift Qty (Feet)	List Price
<b>SDR 21 200#</b>	5"	20'	5.563	5.033	.265	420	<i>Call</i>
	6"	20'	6.625	5.993	.316	600	<i>For</i>
	6 1/8"	20'	6.900	6.242	.329		<i>Price</i>
<b>SDR 17 250#</b>	4 1/2"	20'	4.950	4.368	.291	480	<i>Call</i>
	5"	20'	5.563	4.909	.327	420	<i>For</i>
	6"	20'	6.625	5.845	.390	360	<i>Price</i>
<b>SCH 40</b>	4"	20'	4.500	4.026	.237	720	<i>Call</i>
	4 1/2"	20'	4.950	4.454	.248	480	<i>For</i>
	6"	20'	6.625	6.065	.280	600	<i>Price</i>

**JET STREAM TITELOC PVC SLOTTED WELL CASING**

	Diameter	Slot	Length	Number of Rows	Open Area Square	Lift Qty (Feet)	List Price
<b>SDR 21 200#</b>	5"	.020	20'	4	134	420	
	5"	.035	20'	4	269	420	<i>Call</i>
	6"	.020	20'	5	158	600	<i>For</i>
	6"	.035	20'	5	290	600	<i>Price</i>
<b>SDR 17 250#</b>	4 1/2"	.020	20'	4	122	480	
	4 1/2"	.035	20'	4	214	480	<i>Call</i>
	5"	.020	20'	4	124	420	<i>For</i>
	5"	.035	20'	4	251	420	<i>Price</i>
<b>SCH 40</b>	4"	.020	20'	4	435	720	
	4"	.035	20'	4	218	720	<i>Call</i>
	4 1/2"	.020	20'	4	447	480	<i>For</i>
	4 1/2"	.035	20'	4	224	480	<i>Price</i>
	6"	.035	20'	5	311	600	

**SCH 40 PVC FITTINGS**

**PVC COUPLINGS - SxS**

Size	Box Qty	List Price
3/4"	50	\$ -
1"	50	\$ -
1 1/4"	25	\$ -
1 1/2"	25	\$ -
2"	25	\$ -
2 1/2"	10	\$ -
3"	10	\$ -
4"	5	\$ -
5"	4	\$ -
6"	5	\$ -
8"	4	\$ -



**PVC TEE - SxSxS**

Size	Box Qty	List Price
3/4"	50	\$ -
1"	50	\$ -
1 1/4"	25	\$ -
1 1/2"	25	\$ -
2"	25	\$ -
2 1/2"	10	\$ -
3"	10	\$ -
4"	5	\$ -
5"	4	\$ -
6"	4	\$ -
8"	2	\$ -



**PVC 90° ELBOW - SxS**

Size	Box Qty	List Price
3/4"	50	\$ -
1"	50	\$ -
1 1/4"	25	\$ -
1 1/2"	25	\$ -
2"	25	\$ -
2 1/2"	10	\$ -
3"	10	\$ -
4"	5	\$ -
5"	5	\$ -
6"	4	\$ -
8"	3	\$ -



**PVC 45° ELBOW - SxS**

Size	Box Qty	List Price
3/4"	50	\$ -
1"	50	\$ -
1 1/4"	25	\$ -
1 1/2"	25	\$ -
2"	25	\$ -
2 1/2"	10	\$ -
3"	10	\$ -
4"	5	\$ -
5"	5	\$ -
6"	4	\$ -
8"	4	\$ -



**PVC FEMALE ADAPTER**

Size	Box Qty	List Price
3/4"	50	\$ -
1"	50	\$ -
1 1/4"	25	\$ -
1 1/2"	25	\$ -
2"	25	\$ -
2 1/2"	10	\$ -
3"	10	\$ -
4"	5	\$ -
5"	5	\$ -
6"	4	\$ -
8"	4	\$ -



**PVC MALE ADAPTER**

Size	Box Qty	List Price
3/4"	50	\$ -
1"	50	\$ -
1 1/4"	25	\$ -
1 1/2"	25	\$ -
2"	25	\$ -
2 1/2"	10	\$ -
3"	10	\$ -
4"	5	\$ -
5"	5	\$ -
6"	4	\$ -
8"	4	\$ -



**SCH 40 PVC FITTINGS**

**PVC BUSHING - SxS**

Size	Box Qty	List Price
3/4" X 1/2"	100	\$ -
1" x 1/2"	100	\$ -
1" x 3/4"	100	\$ -
1 1/4" x 1/2"	25	\$ -
1 1/4" x 3/4"	25	\$ -
1 1/4" x 1"	25	\$ -
1 1/2" x 1/2"	25	\$ -
1 1/2" x 3/4"	25	\$ -
1 1/2" x 1"	25	\$ -
1 1/2" x 1 1/4"	25	\$ -
2" x 1/2"	10	\$ -
2" x 3/4"	10	\$ -
2" x 1"	10	\$ -
2" x 1 1/4"	10	\$ -
2" x 1 1/2"	25	\$ -
2 1/2" x 1/2"	10	\$ -
2 1/2" x 3/4"	10	\$ -
2 1/2" x 1"	10	\$ -
2 1/2" x 1 1/4"	10	\$ -
2 1/2" x 1 1/2"	10	\$ -
2 1/2" x 2"	10	\$ -
3" x 1/2"	10	\$ -
3" x 3/4"	10	\$ -
3" x 1"	10	\$ -
3" x 1 1/4"	10	\$ -
3" x 1 1/2"	10	\$ -
3" x 2"	10	\$ -
3" x 2 1/2"	10	\$ -
4" x 1"	5	\$ -
4" x 1 1/4"	5	\$ -
4" x 1 1/2"	5	\$ -
4" x 2"	5	\$ -
4" x 2 1/2"	5	\$ -
4" x 3"	5	\$ -
5" x 3"	5	\$ -
5" x 4"	4	\$ -
6" x 2"	5	\$ -
6" x 3"	5	\$ -
6" x 4"	5	\$ -
6" x 5"	5	\$ -
8" x 2"	5	\$ -
8" x 3"	5	\$ -
8" x 4"	5	\$ -
8" x 5"	4	\$ -
8" x 6"	5	\$ -



**PVC BUSHING - SxT**

Size	Box Qty	List Price
3/4" X 1/2"	100	\$ -
1" x 1/2"	100	\$ -
1" x 3/4"	100	\$ -
1 1/4" x 1/2"	25	\$ -
1 1/4" x 3/4"	25	\$ -
1 1/4" x 1"	25	\$ -
1 1/2" x 1/2"	25	\$ -
1 1/2" x 3/4"	25	\$ -
1 1/2" x 1"	25	\$ -
1 1/2" x 1 1/4"	25	\$ -
2" x 1/2"	10	\$ -
2" x 3/4"	10	\$ -
2" x 1"	10	\$ -
2" x 1 1/4"	10	\$ -
2" x 1 1/2"	10	\$ -
2 1/2" x 1/2"	10	\$ -
2 1/2" x 3/4"	10	\$ -
2 1/2" x 1"	10	\$ -
2 1/2" x 1 1/4"	10	\$ -
2 1/2" x 1 1/2"	10	\$ -
2 1/2" x 2"	10	\$ -
3" x 3/4"	10	\$ -
3" x 1"	10	\$ -
3" x 1 1/4"	10	\$ -
3" x 1 1/2"	10	\$ -
3" x 2"	10	\$ -
3" x 2 1/2"	10	\$ -
4" x 2"	5	\$ -
4" x 2 1/2"	5	\$ -
4" x 3"	5	\$ -
5" x 4"	5	\$ -
6" x 2"	5	\$ -
6" x 4"	5	\$ -



**PVC CROSS - SxSxSxS**

Size	Box Qty	List Price
1"	50	\$ -
1 1/4"	25	\$ -
1 1/2"	25	\$ -
2"	10	\$ -
2 1/2"	8	\$ -
3"	10	\$ -
4"	5	\$ -



**SCH 40 PVC FITTINGS**

**PVC CAP - SLIP**

Size	Box Qty	List Price
3/4"	100	\$ -
1"	50	\$ -
1 1/4"	25	\$ -
1 1/2"	25	\$ -
2"	25	\$ -
2 1/2"	10	\$ -
3"	10	\$ -
4"	5	\$ -
5"	5	\$ -
6"	5	\$ -
8"	4	\$ -



**PVC PLUG - THREADED**

Size	Box Qty	List Price
3/4"	50	\$ -
1"	50	\$ -
1 1/4"	25	\$ -
1 1/2"	25	\$ -
2"	10	\$ -
2 1/2"	10	\$ -
3"	10	\$ -
4"	5	\$ -



**PVC COMPRESSION COUPLING**

Size	Box Qty	List Price
1"	20	\$ -
1 1/4"	10	\$ -
1 1/2"	10	\$ -
2"	10	\$ -
2 1/2"	8	\$ -
3"	5	\$ -
4"	6	\$ -



**EXPANDABLE PVC REPAIR COUPLING**

Size	Box Qty	List Price
1"	18	\$ -
1 1/4"	12	\$ -
1 1/2"	12	\$ -
2"	8	\$ -
2 1/2"	4	\$ -
3"	3	\$ -
4"	2	\$ -



**PVC INSERT FITTINGS**

**PVC INSERT COUPLING**

Size	Box Qty	List Price
1/2"	50	\$ -
3/4"	50	\$ -
1"	50	\$ -
1 1/4"	25	\$ -
1 1/2"	25	\$ -
2"	10	\$ -



**PVC INSERT MALE ADAPTER**

Size	Box Qty	List Price
1/2"	50	\$ -
3/4"	50	\$ -
1"	50	\$ -
1 1/4"	20	\$ -
1 1/2"	25	\$ -
2"	10	\$ -



**SCH 80 PVC FITTINGS**

**SCH 80 PVC UNION - SxS**

Size	Box Qty	List Price
1"	10	\$ -
1 1/4"	5	\$ -
1 1/2"	5	\$ -
2"	5	\$ -
3"	5	\$ -
4"	2	\$ -



**SCH 80 PVC UNION - TxT**

Size	Box Qty	List Price
1"	10	\$ -
1 1/4"	5	\$ -
1 1/2"	5	\$ -
2"	5	\$ -
3"	5	\$ -
4"	4	\$ -



**SCH 80 PVC FEMALE ADAPTER**

Size	Box Qty	List Price
1"	10	\$ -
1 1/4"	5	\$ -
1 1/2"	5	\$ -
2"	5	\$ -
3"	5	\$ -
4"	2	\$ -



**SCH 80 PVC MALE ADAPTER**

Size	Box Qty	List Price
1"	10	\$ -
1 1/4"	5	\$ -
1 1/2"	5	\$ -
2"	5	\$ -
3"	5	\$ -
4"	4	\$ -



**SCH 80 PVC NIPPLE - TxT**

Size	Box Qty	List Price
1" x Close	50	\$ -
1" x 2"	50	\$ -
1" x 4"	50	\$ -
1" x 6"	50	\$ -
1" x 8"	50	\$ -
1" x 10"	50	\$ -
1" x 12"	50	\$ -



**SCH 80 PVC NIPPLE - TxT**

Size	Box Qty	List Price
1 1/4" x Close	25	\$ -
1 1/4" x 2"	25	\$ -
1 1/4" x 4"	25	\$ -
1 1/4" x 6"	25	\$ -
1 1/4" x 8"	25	\$ -
1 1/4" x 10"	25	\$ -
1 1/4" x 12"	25	\$ -



**SCH 80 PVC NIPPLE - TxT**

Size	Box Qty	List Price
1 1/2" x Close	25	\$ -
1 1/2" x 4"	25	\$ -
1 1/2" x 6"	25	\$ -
1 1/2" x 8"	25	\$ -
1 1/2" x 10"	25	\$ -
1 1/2" x 12"	25	\$ -



**SCH 80 PVC NIPPLE - TxT**

Size	Box Qty	List Price
2" x Close	10	\$ -
2" x 4"	10	\$ -
2" x 6"	10	\$ -
2" x 8"	10	\$ -
2" x 10"	10	\$ -
2" x 12"	15	\$ -



**STAINLESS STEEL CLAMPS**

Mfg Number	Description	Size	Box Quantity	List Price
6308	8	7/16" x 1"	10	\$ -
6310	10	1/2" x 1-1/16"	10	\$ -
6312	12	1/2" x 1-1/4"	10	\$ -
6316	16	11/16" x 1-1/2"	10	\$ -
6320	20	3/4" x 1-3/4"	10	\$ -
6324	24	1" x 2"	10	\$ -
6328	28	1-15/16" x 2-1/2"	10	\$ -
6332	32	1-1/2" x 2-1/2"	10	\$ -
6336	36	1-3/4" x 2-3/4"	10	\$ -
6340	40	2" x 3"	10	\$ -
6352	52	2-3/4" x 3-3/4"	10	\$ -
6364	64	2-1/2" x 4-1/2"	10	\$ -
6372	72	3" x 5"	10	\$ -
6380	80	3-1/2" x 5-1/2"	10	\$ -
6396	96	4-1/2" x 6-1/2"	10	\$ -
63104	104	5" x 7"	10	\$ -
63128	128	6-1/2" x 8-1/2"	10	\$ -
63152	152	8" x 10"	10	\$ -



**PVC Solvents**

PVC Cement - J.C. Whitlam	Item #	Size	Case Quantity	List Price
PVC Clear Med Bodied / Med Set	PL4	1/4 Pint	24	\$ -
PVC Clear Med Bodied / Med Set	PL8	1/2 Pint	24	\$ -
PVC Clear Med Bodied / Med Set	PL16	Pint	12	\$ -
PVC Clear Med Bodied / Med Set	PL32	Quart	12	\$ -
PVC Clear Med Bodied / Med Set	PL1-CGW	Gallon	6	\$ -
PVC Clear Heavy Duty / Med Set	HDP4	1/4 Pint	24	\$ -
PVC Clear Heavy Duty / Med Set	HDP8	1/2 Pint	24	\$ -
PVC Clear Heavy Duty / Med Set	HDP16	Pint	12	\$ -
PVC Clear Heavy Duty / Med Set	HDP32	Quart	12	\$ -
PVC Clear Heavy Duty / Med Set	HDP1-CGW	Gallon	6	\$ -
"Weatherproof" Blue Wet/Dry Med Body / Fast Set	WET4	1/4 Pint	24	\$ -
"Weatherproof" Blue Wet/Dry Med Body / Fast Set	WET8	1/2 Pint	24	\$ -
"Weatherproof" Blue Wet/Dry Med Body / Fast Set	WET16	Pint	12	\$ -
"Weatherproof" Blue Wet/Dry Med Body / Fast Set	WET32	Quart	12	\$ -
"Weatherproof" Blue Wet/Dry Med Body / Fast Set	WET1-CGW	Gallon	6	\$ -
PVC Gray SCH. 80 Heavy Bodied / Slow Set	PGL16	Pint	12	\$ -
PVC Gray SCH. 80 Heavy Bodied / Slow Set	PGL32	Quart	12	\$ -
PVC Gray SCH. 80 Heavy Bodied / Slow Set	PGL1-CGW	Gallon	6	\$ -



**Average Joint Cure Schedule For WHITLAM PVC/CPVC Solvent Cements\*\***

Relative Humidity 60% or Less	Cure Time Pipe Sizes 1/2" to 1 1/4"		Cure Time Pipe Sizes 1 1/2" to 2"		Cure Time Pipe Sizes 2 1/2" to 8"		Cure Time Pipe Sizes 10" to 15"	Cure Time Pipe Sizes 15"+
	up to 160 psi	160 to 370 psi	up to 160 psi	above 160 to 315 psi	up to 160 psi	above 160 to 315 psi	up to 100 psi	up to 100 psi
60°- 100°F	15 min	6 hrs	30 min	12 hrs	1 1/2 hrs	24 hrs	48 hrs	72 hrs
40°- 60°F	20 min	12 hrs	45 min	24 hrs	4 hrs	48 hrs	96 hrs	6 days
0°- 40°F	30 min	48 hrs	1 hour	96 hrs	72 hrs	8 days	8 days	14 days

Note-Joint cure schedule is the necessary time to allow before pressurizing system. In damp or humid weather allow 50% more cure time.

\*\* These figures are estimates based on our laboratory tests; extended cure times are required for chemical applications. Due to the many variables in the field, these figures should be used as a general guide only.



**PVC Solvents**

**Clear PVC Primer - J.C. Whitlam**

	Item #	Size	Case Quantity	List Price
Low Voc Clear Primer	PCL4	1/4 Pint	24	\$ -
Low Voc Clear Primer	PCL8	1/2 Pint	24	\$ -
Low Voc Clear Primer	PCL16	Pint	12	\$ -
Low Voc Clear Primer	PCL32	Quart	12	\$ -
Low Voc Clear Primer	PCL1-CGW	Gallon	6	\$ -



**Purple PVC Primer - J.C. Whitlam**

Low Voc Purple Primer	PPL4	1/4 Pint	24	\$ -
Low Voc Purple Primer	PPL8	1/2 Pint	24	\$ -
Low Voc Purple Primer	PPL16	Pint	12	\$ -
Low Voc Purple Primer	PPL32	Quart	12	\$ -
Low Voc Purple Primer	PPL1-CGW	Gallon	6	\$ -



**PVC Cleaner - J.C. Whitlam**

Low Voc Clear Cleaner	C4	1/4 Pint	24	\$ -
Low Voc Clear Cleaner	C8	1/2 Pint	24	\$ -
Low Voc Clear Cleaner	C16	Pint	12	\$ -
Low Voc Clear Cleaner	C32	Quart	12	\$ -
Low Voc Clear Cleaner	C1-CGW	Gallon	6	\$ -



**Pipe Gasket Lube - J.C. Whitlam**

Blue Lube Polymer Based	GLP16	Pint	24	\$ -
Blue Lube Polymer Based	GLP32	Quart	12	\$ -
Blue Lube Polymer Based	GLP16	Gallon	4	\$ -
Blue Lube Polymer Based	GLP5	5 Gallon		\$ -



Accessories	Size	Case Quantity	List Price
Gallon Can Swab with Cap	12"	12	\$ -



Talon Heavy Duty Hand Cleaning Towels	9" x 12"	6	\$ -
---------------------------------------	----------	---	------



DAP Quick Cure High Yield Polyurethane Foam	11 oz	12	\$ -
---	-------	----	------



**POLY PIPE & FITTINGS**

**SDR 11 Poly Pipe**

Diameter	Pressure Rating	Length	List Price
1"	SDR11 / 200 PSI	500'	
1-1/4"	SDR11 / 200 PSI	500'	<i>Call</i>
1-1/2"	SDR11 / 200 PSI	500'	<i>For</i>
2"	SDR11 / 200 PSI	2000'	<i>Price</i>
3"	SDR11 / 200 PSI	1000'	
4"	SDR11 / 200 PSI	500' or 800'	



**SDR11 Fusible Poly Transitions**

Size	Description	Box Qty	List Price
1-1/4"	MPT X IPS DR11 COATED TRANSITION	16	\$ -
1-1/2"	MPT X IPS DR11 COATED TRANSITION	12	\$ -
2"	MPT X IPS DR11 COATED TRANSITION	16	\$ -
3"	MPT X IPS DR11 COATED TRANSITION	4	\$ -
4"	MPT X IPS DR11 COATED TRANSITION	4	\$ -

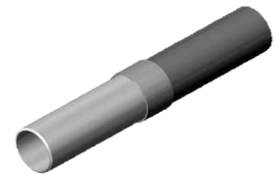

**Threaded Hammer Unions**

Size	Description	List Price
2"	Threaded Hammer Union / 1000 PSI	\$ -
3"	Threaded Hammer Union / 1000 PSI	\$ -
4"	Threaded Hammer Union / 1000 PSI	\$ -



**Polymate Threaded Adapters**

Size	Description	List Price
1"	304SS Polymate Threaded Adapter	\$ -
1-1/4"	304SS Polymate Threaded Adapter	\$ -
1-1/2"	304SS Polymate Threaded Adapter	\$ -
2"	304SS Polymate Threaded Adapter	\$ -
3"	304SS Polymate Threaded Adapter	\$ -
4"	304SS Polymate Threaded Adapter	\$ -



**PEX TUBING**

Nominal Size	OD	Wall	Calculated ID	Length	Color	List Price
3/4"	.875"	.097"	.681"	10' Stick	White	\$ -
3/4"	.875"	.097"	.681"	20' Stick	White	\$ -
3/4"	.875"	.097"	.681"	100' Coil	White	\$ -
1"	1.125"	.125"	.875"	10' Stick	White	\$ -
1"	1.125"	.125"	.875"	20' Stick	White	\$ -
1"	1.125"	.125"	.875"	100' Coil	White	\$ -

PowerPEX is available in copper tube sizes (CTS) ½" through 2". Coils are available up to 1". Straight lengths are available for every size. ½" – 1" available in red, white or blue. 1¼" – 2" available in white only.



**Proudly Made in America**

Domestic materials. Domestic manufacture. Made in America using the best materials possible with the best people possible



**1.** Cut tube at 90-degrees. Do not crush OD of tubing with cutters.  
Hint: Slightly rotate cutter during blade engagement.



**2.** Install PEX Crimp Ring onto OD of tubing.



**3.** Install PEX fitting into tube end.



**4.** Position ring over sealing barbs of the fitting. The ring should be positioned approximately 1/8" to 1/4" from the end of the tube.



**5.** Compress tool perpendicular to tubing run. Compress only once. Remove defective connections. Use a gauge to assure a proper joint. Test completed joint.

**PEX FITTINGS**

Configuration	Material	Size	Box Qty	List Price
Crimp Ring	Copper	3/4"	100	\$ -
Crimp Ring	Copper	1"	100	\$ -
Female Adapter	Brass	3/4"	25	\$ -
Female Adapter	Brass	1"	15	\$ -
Female Adapter	Poly	3/4"	-	\$ -
Female Adapter	Poly	1"	25	\$ -
Male Adapter	Brass	3/4"	25	\$ -
Male Adapter	Brass	1"	15	\$ -
Male Adapter	Poly	3/4"	-	\$ -
Male Adapter	Poly	1"	25	\$ -
Reducing Male Adapter	Brass	1" PEX x 3/4" MA	15	\$ -
90 Deg Elbow	Brass	3/4"	25	\$ -
90 Deg Elbow	Brass	1"	15	\$ -
90 Deg Elbow	Poly	3/4"	-	\$ -
90 Deg Elbow	Poly	1"	10	\$ -
Coupling	Brass	3/4"	25	\$ -
Coupling	Brass	1"	15	\$ -
Coupling	Poly	3/4"	-	\$ -
Coupling	Poly	1"	25	\$ -
Tee	Brass	3/4"	25	\$ -
Tee	Brass	1"	15	\$ -
Tee	Poly	3/4"	-	\$ -
Tee	Poly	1"	10	\$ -
PEX x PEX Ball Valve	Brass	3/4"	10	\$ -
PEX x PEX Ball Valve	Brass	1"	6	\$ -
1" PEX Crimping Tool				\$ -
3/8" - 1 1/4" Ratcheting Tube Cutter				\$ -
PEX Go/No-Go Gauge 3/8", 1/2", 3/4" & 1"				\$ -

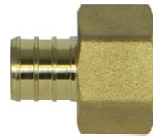

**STEEL PIPE**

	Diameter	Length	Outside Diameter	Inside Diameter	Wall Thickness	Lift Qty (Feet)	Weight Per Foot (lbs)	List Price
<b>Black T&amp;C Steel Drop Pipe</b>	1/2"	21'	.840"	.622"	.109"	2520	0.85	
	3/4"	21'	1.050"	.824"	.113"	1764	1.13	
	1"	21'	1.315"	1.049"	.133"	1260	1.68	
	1¼"	21'	1.660"	1.380"	.140"	882	2.27	
	1½"	21'	1.900"	1.610"	.145"	756	2.72	Call
	2"	21'	2.375"	2.067"	.154"	546	3.65	For
	2½"	21'	2.875"	2.469"	.203"	378	5.79	Price
	3"	21'	3.500"	3.068"	.216"	294	7.58	
	4"	21'	4.500"	4.026"	.237"	210	10.79	
	5"	21'	5.563"	5.047"	.258"	147	14.61	
	6"	21'	6.625"	6.065"	.280"	147	18.97	

	Diameter	Length	Outside Diameter	Inside Diameter	Wall Thickness	Lift Qty (Feet)	Weight Per Foot (lb)	List Price
<b>Galvanized T&amp;C Steel Drop Pipe</b>	1/2"	21'	.840"	.622"	.109"	2520	0.85	
	3/4"	21'	1.050"	.824"	.113"	1764	1.13	
	1"	21'	1.315"	1.049"	.133"	1260	1.68	
	1¼"	21'	1.660"	1.380"	.140"	882	2.27	
	1½"	21'	1.900"	1.610"	.145"	756	2.72	Call
	2"	21'	2.375"	2.067"	.154"	546	3.65	For
	2½"	21'	2.875"	2.469"	.203"	378	5.79	Price
	3"	21'	3.500"	3.068"	.216"	294	7.58	
	4"	21'	4.500"	4.026"	.237"	210	10.79	
	5"	21'	5.563"	5.047"	.258"	147	14.61	
	6"	21'	6.625"	6.065"	.280"	147	18.97	

**90° Elbows - Class 150**

Black		
Size	Box Qty	List Price
1/8"	50	\$ -
1/4"	35	\$ -
3/8"	90	\$ -
1/2"	50	\$ -
3/4"	35	\$ -
1"	20	\$ -
1 1/4"	20	\$ -
1 1/2"	10	\$ -
2"	8	\$ -
2 1/2"	12	\$ -
3"	8	\$ -
4"	2	\$ -
5"	2	\$ -
6"	-	\$ -



Galvanized		
Size	Box Qty	List Price
1/8"	50	\$ -
1/4"	35	\$ -
3/8"	90	\$ -
1/2"	50	\$ -
3/4"	35	\$ -
1"	20	\$ -
1 1/4"	20	\$ -
1 1/2"	15	\$ -
2"	8	\$ -
2 1/2"	12	\$ -
3"	8	\$ -
4"	2	\$ -
5"	-	\$ -
6"	-	\$ -

**90° Street Elbows - Class 150**

Black		
Size	Box Qty	List Price
1/8"	60	\$ -
1/4"	35	\$ -
3/8"	40	\$ -
1/2"	60	\$ -
3/4"	35	\$ -
1"	45	\$ -
1 1/4"	25	\$ -
1 1/2"	9	\$ -
2"	8	\$ -
2 1/2"	5	\$ -
3"	8	\$ -
4"	4	\$ -
6"	-	\$ -



Galvanized		
Size	Box Qty	List Price
1/8"	60	\$ -
1/4"	35	\$ -
3/8"	40	\$ -
1/2"	60	\$ -
3/4"	35	\$ -
1"	45	\$ -
1 1/4"	25	\$ -
1 1/2"	9	\$ -
2"	8	\$ -
2 1/2"	5	\$ -
3"	8	\$ -
4"	4	\$ -
6"	-	\$ -

**45° Elbows - Class 150**

Black		
Size	Box Qty	List Price
1/8"	50	\$ -
1/4"	30	\$ -
3/8"	50	\$ -
1/2"	50	\$ -
3/4"	40	\$ -
1"	20	\$ -
1 1/4"	20	\$ -
1 1/2"	10	\$ -
2"	12	\$ -
2 1/2"	12	\$ -
3"	10	\$ -
4"	4	\$ -
5"	-	\$ -
6"	-	\$ -



Galvanized		
Size	Box Qty	List Price
1/8"	50	\$ -
1/4"	35	\$ -
3/8"	60	\$ -
1/2"	50	\$ -
3/4"	40	\$ -
1"	20	\$ -
1 1/4"	20	\$ -
1 1/2"	10	\$ -
2"	12	\$ -
2 1/2"	12	\$ -
3"	10	\$ -
4"	4	\$ -
5"	-	\$ -
6"	-	\$ -

**Tee - Class 150**

Black		
Size	Box Qty	List Price
1/8"	80	\$ -
1/4"	50	\$ -
3/8"	30	\$ -
1/2"	40	\$ -
3/4"	35	\$ -
1"	20	\$ -
1 1/4"	14	\$ -
1 1/2"	12	\$ -
2"	8	\$ -
2 1/2"	8	\$ -
3"	6	\$ -
4"	2	\$ -
5"	-	\$ -
6"	-	\$ -



Galvanized		
Size	Box Qty	List Price
1/8"	120	\$ -
1/4"	50	\$ -
3/8"	30	\$ -
1/2"	40	\$ -
3/4"	35	\$ -
1"	20	\$ -
1 1/4"	14	\$ -
1 1/2"	12	\$ -
2"	8	\$ -
2 1/2"	8	\$ -
3"	6	\$ -
4"	2	\$ -
5"	-	\$ -
6"	-	\$ -

### Reducing Tee - Class 150

Black		
Size	Box Qty	List Price
1 1/4" x 3/4"	20	\$ -
1 1/4" x 1"	20	\$ -



Galvanized		
Size	Box Qty	List Price
1 1/4" x 3/4"	20	\$ -
1 1/4" x 1"	20	\$ -

### Cross - Class 150

Black		
Size	Box Qty	List Price
1/4"	40	\$ -
3/8"	50	\$ -
1/2"	30	\$ -
3/4"	20	\$ -
1"	15	\$ -
1 1/4"	10	\$ -
1 1/2"	8	\$ -
2"	5	\$ -
2 1/2"	6	\$ -
3"	4	\$ -
4"	2	\$ -



Galvanized		
Size	Box Qty	List Price
1/4"	40	\$ -
3/8"	50	\$ -
1/2"	30	\$ -
3/4"	20	\$ -
1"	15	\$ -
1 1/4"	10	\$ -
1 1/2"	8	\$ -
2"	5	\$ -
2 1/2"	3	\$ -
3"	2	\$ -
4"	2	\$ -

### Square Head Plug - Class 150

Black		
Size	Box Qty	List Price
1/8"	100	\$ -
1/4"	100	\$ -
3/8"	100	\$ -
1/2"	100	\$ -
3/4"	30	\$ -
1"	20	\$ -
1 1/4"	40	\$ -
1 1/2"	30	\$ -
2"	20	\$ -
2 1/2"	16	\$ -
3"	16	\$ -
4"	12	\$ -
5"	10	\$ -
6"	10	\$ -



Galvanized		
Size	Box Qty	List Price
1/8"	100	\$ -
1/4"	100	\$ -
3/8"	100	\$ -
1/2"	100	\$ -
3/4"	30	\$ -
1"	20	\$ -
1 1/4"	40	\$ -
1 1/2"	30	\$ -
2"	20	\$ -
2 1/2"	16	\$ -
3"	16	\$ -
4"	6	\$ -
5"	-	\$ -
6"	5	\$ -



### Cap - Class 150

Black			Galvanized		
Size	Box Qty	List Price	Size	Box Qty	List Price
1/8"	120	\$ -	1/8"	100	\$ -
1/4"	80	\$ -	1/4"	100	\$ -
3/8"	60	\$ -	3/8"	60	\$ -
1/2"	75	\$ -	1/2"	75	\$ -
3/4"	40	\$ -	3/4"	40	\$ -
1"	25	\$ -	1"	25	\$ -
1 1/4"	20	\$ -	1 1/4"	20	\$ -
1 1/2"	18	\$ -	1 1/2"	18	\$ -
2"	12	\$ -	2"	12	\$ -
2 1/2"	20	\$ -	2 1/2"	20	\$ -
3"	24	\$ -	3"	24	\$ -
4"	12	\$ -	4"	12	\$ -
5"	10	\$ -	5"	10	\$ -
6"	4	\$ -	6"	4	\$ -



### Union - Class 150

Black			Galvanized		
Size	Box Qty	List Price	Size	Box Qty	List Price
1/8"	30	\$ -	1/8"	30	\$ -
1/4"	20	\$ -	1/4"	20	\$ -
3/8"	20	\$ -	3/8"	20	\$ -
1/2"	50	\$ -	1/2"	50	\$ -
3/4"	35	\$ -	3/4"	35	\$ -
1"	20	\$ -	1"	20	\$ -
1 1/4"	15	\$ -	1 1/4"	15	\$ -
1 1/2"	10	\$ -	1 1/2"	10	\$ -
2"	12	\$ -	2"	12	\$ -
2 1/2"	8	\$ -	2 1/2"	8	\$ -
3"	8	\$ -	3"	8	\$ -
4"	4	\$ -	4"	4	\$ -



### Reducer Couplings - Class 150

Black			Galvanized		
Size	Box Qty	List Price	Size	Box Qty	List Price
3/4" x 1/2"	60	\$ -	3/4" x 1/2"	60	\$ -
1" x 1/2"	30	\$ -	1" x 1/2"	30	\$ -
1" x 3/4"	25	\$ -	1" x 3/4"	25	\$ -
1 1/4" x 1"	15	\$ -	1 1/4" x 1"	15	\$ -
1 1/2" x 1"	25	\$ -	1 1/2" x 1"	25	\$ -
1 1/2" x 1 1/4"	12	\$ -	1 1/2" x 1 1/4"	12	\$ -
2" x 1"	12	\$ -	2" x 1"	12	\$ -
2" x 1 1/4"	9	\$ -	2" x 1 1/4"	9	\$ -
2" x 1 1/2"	9	\$ -	2" x 1 1/2"	9	\$ -
2 1/2" x 2"	7	\$ -	2 1/2" x 2"	7	\$ -
3" x 2"	6	\$ -	3" x 2"	6	\$ -
3" x 2 1/2"	5	\$ -	3" x 2 1/2"	5	\$ -
4" x 2"	3	\$ -	4" x 2"	3	\$ -
4" x 2 1/2"	3	\$ -	4" x 2 1/2"	3	\$ -
4" x 3"	3	\$ -	4" x 3"	3	\$ -
5" x 4"	-	\$ -	5" x 4"	-	\$ -
6" x 4"	2	\$ -	6" x 4"	2	\$ -
6" x 5"	2	\$ -	6" x 5"	-	\$ -



### Merchant Couplings - Sch 40

Black			Galvanized		
Size	Box Qty	List Price	Size	Box Qty	List Price
1/8"	100	\$ -	1/8"	100	\$ -
1/4"	100	\$ -	1/4"	100	\$ -
3/8"	100	\$ -	3/8"	100	\$ -
1/2"	100	\$ -	1/2"	100	\$ -
3/4"	50	\$ -	3/4"	50	\$ -
1"	30	\$ -	1"	30	\$ -
1 1/4"	25	\$ -	1 1/4"	25	\$ -
1 1/2"	25	\$ -	1 1/2"	25	\$ -
2"	20	\$ -	2"	20	\$ -
2 1/2"	24	\$ -	2 1/2"	24	\$ -
3"	18	\$ -	3"	18	\$ -
4"	12	\$ -	4"	12	\$ -
5"	6	\$ -	5"	6	\$ -
6"	4	\$ -	6"	4	\$ -



### Hex Bushings - Class 150

Black			Galvanized		
Size	Box Qty	List Price	Size	Box Qty	List Price
1/4" x 1/8"	100	\$ -	1/4" x 1/8"	100	\$ -
3/8" x 1/8"	100	\$ -	3/8" x 1/8"	100	\$ -
3/8" x 1/4"	100	\$ -	3/8" x 1/4"	100	\$ -
1/2" x 1/4"	100	\$ -	1/2" x 1/4"	100	\$ -
1/2" x 3/8"	100	\$ -	1/2" x 3/8"	100	\$ -
3/4" x 1/4"	75	\$ -	3/4" x 1/4"	75	\$ -
3/4" x 3/8"	75	\$ -	3/4" x 3/8"	75	\$ -
3/4" x 1/2"	75	\$ -	3/4" x 1/2"	75	\$ -
1" x 1/4"	50	\$ -	1" x 1/4"	50	\$ -
1" x 3/8"	50	\$ -	1" x 3/8"	50	\$ -
1" x 1/2"	50	\$ -	1" x 1/2"	50	\$ -
1" x 3/4"	50	\$ -	1" x 3/4"	50	\$ -
1 1/4" x 1/4"	30	\$ -	1 1/4" x 1/4"	30	\$ -
1 1/4" x 3/4"	30	\$ -	1 1/4" x 3/4"	30	\$ -
1 1/4" x 1"	30	\$ -	1 1/4" x 1"	30	\$ -
1 1/2" x 3/4"	25	\$ -	1 1/2" x 3/4"	25	\$ -
1 1/2" x 1"	25	\$ -	1 1/2" x 1"	25	\$ -
1 1/2" x 1 1/4"	25	\$ -	1 1/2" x 1 1/4"	25	\$ -
2" x 1/4"	20	\$ -	2" x 1/4"	20	\$ -
2" x 3/4"	20	\$ -	2" x 3/4"	20	\$ -
2" x 1"	20	\$ -	2" x 1"	20	\$ -
2" x 1 1/4"	20	\$ -	2" x 1 1/4"	20	\$ -
2" x 1 1/2"	20	\$ -	2" x 1 1/2"	20	\$ -
2 1/2" x 1"	15	\$ -	2 1/2" x 1"	15	\$ -
2 1/2" x 1 1/4"	15	\$ -	2 1/2" x 1 1/4"	15	\$ -
2 1/2" x 1 1/2"	15	\$ -	2 1/2" x 1 1/2"	15	\$ -
2 1/2" x 2"	15	\$ -	2 1/2" x 2"	15	\$ -
3" x 1"	12	\$ -	3" x 1"	12	\$ -
3" x 1 1/4"	12	\$ -	3" x 1 1/4"	12	\$ -
3" x 1 1/2"	12	\$ -	3" x 1 1/2"	12	\$ -
3" x 2"	12	\$ -	3" x 2"	12	\$ -
3" x 2 1/2"	12	\$ -	3" x 2 1/2"	12	\$ -
4" x 2"	5	\$ -	4" x 2"	5	\$ -
4" x 2 1/2"	5	\$ -	4" x 2 1/2"	5	\$ -
4" x 3"	5	\$ -	4" x 3"	5	\$ -
5" x 3"	2	\$ -	5" x 3"	2	\$ -
5" x 4"	2	\$ -	5" x 4"	2	\$ -
6" x 4"	2	\$ -	6" x 4"	2	\$ -
6" x 5"	2	\$ -	6" x 5"	2	\$ -



### Steel Pipe Nipples - Sch 40

<b>Black</b>		
Size	Box Qty	List Price
1/8" x Close	25	\$ -
1/8" x 1 1/2"	25	\$ -
1/8" x 2"	25	\$ -
1/8" x 2 1/2"	25	\$ -
1/8" x 3"	25	\$ -
1/8" x 3 1/2"	25	\$ -
1/8" x 4"	25	\$ -
1/8" x 4 1/2"	25	\$ -
1/8" x 5"	25	\$ -
1/8" x 5 1/2"	25	\$ -
1/8" x 6"	25	\$ -
1/8" x 7"	25	\$ -
1/8" x 8"	25	\$ -
1/8" x 9"	25	\$ -
1/8" x 10"	25	\$ -
1/8" x 11"	25	\$ -
1/8" x 12"	25	\$ -



<b>Galvanized</b>		
Size	Box Qty	List Price
1/8" x Close	25	\$ -
1/8" x 1 1/2"	25	\$ -
1/8" x 2"	25	\$ -
1/8" x 2 1/2"	25	\$ -
1/8" x 3"	25	\$ -
1/8" x 3 1/2"	25	\$ -
1/8" x 4"	25	\$ -
1/8" x 4 1/2"	25	\$ -
1/8" x 5"	25	\$ -
1/8" x 5 1/2"	25	\$ -
1/8" x 6"	25	\$ -
1/8" x 7"	25	\$ -
1/8" x 8"	25	\$ -
1/8" x 9"	25	\$ -
1/8" x 10"	25	\$ -
1/8" x 11"	25	\$ -
1/8" x 12"	25	\$ -

<b>Black</b>		
Size	Box Qty	List Price
1/4" x Close	25	\$ -
1/4" x 1 1/2"	25	\$ -
1/4" x 2"	25	\$ -
1/4" x 2 1/2"	25	\$ -
1/4" x 3"	25	\$ -
1/4" x 3 1/2"	25	\$ -
1/4" x 4"	25	\$ -
1/4" x 4 1/2"	25	\$ -
1/4" x 5"	25	\$ -
1/4" x 5 1/2"	25	\$ -
1/4" x 6"	25	\$ -
1/4" x 7"	25	\$ -
1/4" x 8"	25	\$ -
1/4" x 9"	25	\$ -
1/4" x 10"	25	\$ -
1/4" x 11"	25	\$ -
1/4" x 12"	25	\$ -



<b>Galvanized</b>		
Size	Box Qty	List Price
1/4" x Close	25	\$ -
1/4" x 1 1/2"	25	\$ -
1/4" x 2"	25	\$ -
1/4" x 2 1/2"	25	\$ -
1/4" x 3"	25	\$ -
1/4" x 3 1/2"	25	\$ -
1/4" x 4"	25	\$ -
1/4" x 4 1/2"	25	\$ -
1/4" x 5"	25	\$ -
1/4" x 5 1/2"	25	\$ -
1/4" x 6"	25	\$ -
1/4" x 7"	25	\$ -
1/4" x 8"	25	\$ -
1/4" x 9"	25	\$ -
1/4" x 10"	25	\$ -
1/4" x 11"	25	\$ -
1/4" x 12"	25	\$ -

### Steel Pipe Nipples - Sch 40

<b>Black</b>		
Size	Box Qty	List Price
3/8" x Close	25	\$ -
3/8" x 1 1/2"	25	\$ -
3/8" x 2"	25	\$ -
3/8" x 2 1/2"	25	\$ -
3/8" x 3"	25	\$ -
3/8" x 3 1/2"	25	\$ -
3/8" x 4"	25	\$ -
3/8" x 4 1/2"	25	\$ -
3/8" x 5"	25	\$ -
3/8" x 5 1/2"	25	\$ -
3/8" x 6"	25	\$ -
3/8" x 7"	25	\$ -
3/8" x 8"	25	\$ -
3/8" x 9"	25	\$ -
3/8" x 10"	25	\$ -
3/8" x 11"	25	\$ -
3/8" x 12"	25	\$ -



<b>Galvanized</b>		
Size	Box Qty	List Price
3/8" x Close	25	\$ -
3/8" x 1 1/2"	25	\$ -
3/8" x 2"	25	\$ -
3/8" x 2 1/2"	25	\$ -
3/8" x 3"	25	\$ -
3/8" x 3 1/2"	25	\$ -
3/8" x 4"	25	\$ -
3/8" x 4 1/2"	25	\$ -
3/8" x 5"	25	\$ -
3/8" x 5 1/2"	25	\$ -
3/8" x 6"	25	\$ -
3/8" x 7"	25	\$ -
3/8" x 8"	25	\$ -
3/8" x 9"	25	\$ -
3/8" x 10"	25	\$ -
3/8" x 11"	25	\$ -
3/8" x 12"	25	\$ -

<b>Black</b>		
Size	Box Qty	List Price
1/2" x Close	25	\$ -
1/2" x 1 1/2"	25	\$ -
1/2" x 2"	25	\$ -
1/2" x 2 1/2"	25	\$ -
1/2" x 3"	25	\$ -
1/2" x 3 1/2"	25	\$ -
1/2" x 4"	25	\$ -
1/2" x 4 1/2"	25	\$ -
1/2" x 5"	25	\$ -
1/2" x 5 1/2"	25	\$ -
1/2" x 6"	25	\$ -
1/2" x 7"	25	\$ -
1/2" x 8"	25	\$ -
1/2" x 9"	25	\$ -
1/2" x 10"	25	\$ -
1/2" x 11"	25	\$ -
1/2" x 12"	25	\$ -



<b>Galvanized</b>		
Size	Box Qty	List Price
1/2" x Close	25	\$ -
1/2" x 1 1/2"	25	\$ -
1/2" x 2"	25	\$ -
1/2" x 2 1/2"	25	\$ -
1/2" x 3"	25	\$ -
1/2" x 3 1/2"	25	\$ -
1/2" x 4"	25	\$ -
1/2" x 4 1/2"	25	\$ -
1/2" x 5"	25	\$ -
1/2" x 5 1/2"	25	\$ -
1/2" x 6"	25	\$ -
1/2" x 7"	25	\$ -
1/2" x 8"	25	\$ -
1/2" x 9"	25	\$ -
1/2" x 10"	25	\$ -
1/2" x 11"	25	\$ -
1/2" x 12"	25	\$ -

### Steel Pipe Nipples - Sch 40

<b>Black</b>		
Size	Box Qty	List Price
3/4" x Close	25	\$ -
3/4" x 1 1/2"	25	\$ -
3/4" x 2"	25	\$ -
3/4" x 2 1/2"	25	\$ -
3/4" x 3"	25	\$ -
3/4" x 3 1/2"	25	\$ -
3/4" x 4"	25	\$ -
3/4" x 4 1/2"	25	\$ -
3/4" x 5"	25	\$ -
3/4" x 5 1/2"	25	\$ -
3/4" x 6"	25	\$ -
3/4" x 7"	25	\$ -
3/4" x 8"	25	\$ -
3/4" x 9"	25	\$ -
3/4" x 10"	25	\$ -
3/4" x 11"	25	\$ -
3/4" x 12"	25	\$ -



<b>Galvanized</b>		
Size	Box Qty	List Price
3/4" x Close	25	\$ -
3/4" x 1 1/2"	25	\$ -
3/4" x 2"	25	\$ -
3/4" x 2 1/2"	25	\$ -
3/4" x 3"	25	\$ -
3/4" x 3 1/2"	25	\$ -
3/4" x 4"	25	\$ -
3/4" x 4 1/2"	25	\$ -
3/4" x 5"	25	\$ -
3/4" x 5 1/2"	25	\$ -
3/4" x 6"	25	\$ -
3/4" x 7"	25	\$ -
3/4" x 8"	25	\$ -
3/4" x 9"	25	\$ -
3/4" x 10"	25	\$ -
3/4" x 11"	25	\$ -
3/4" x 12"	25	\$ -

<b>Black</b>		
Size	Box Qty	List Price
1" x Close	25	\$ -
1" x 2"	25	\$ -
1" x 2 1/2"	25	\$ -
1" x 3"	25	\$ -
1" x 3 1/2"	25	\$ -
1" x 4"	25	\$ -
1" x 4 1/2"	25	\$ -
1" x 5"	25	\$ -
1" x 5 1/2"	25	\$ -
1" x 6"	25	\$ -
1" x 7"	25	\$ -
1" x 8"	25	\$ -
1" x 9"	25	\$ -
1" x 10"	25	\$ -
1" x 11"	25	\$ -
1" x 12"	25	\$ -



<b>Galvanized</b>		
Size	Box Qty	List Price
1" x Close	25	\$ -
1" x 2"	25	\$ -
1" x 2 1/2"	25	\$ -
1" x 3"	25	\$ -
1" x 3 1/2"	25	\$ -
1" x 4"	25	\$ -
1" x 4 1/2"	25	\$ -
1" x 5"	25	\$ -
1" x 5 1/2"	25	\$ -
1" x 6"	25	\$ -
1" x 7"	25	\$ -
1" x 8"	25	\$ -
1" x 9"	25	\$ -
1" x 10"	25	\$ -
1" x 11"	25	\$ -
1" x 12"	25	\$ -

### Steel Pipe Nipples - Sch 40

<b>Black</b>		
Size	Box Qty	List Price
1 1/4" x Close	5	\$ -
1 1/4" x 2"	5	\$ -
1 1/4" x 2 1/2"	5	\$ -
1 1/4" x 3"	5	\$ -
1 1/4" x 3 1/2"	5	\$ -
1 1/4" x 4"	5	\$ -
1 1/4" x 4 1/2"	5	\$ -
1 1/4" x 5"	5	\$ -
1 1/4" x 5 1/2"	5	\$ -
1 1/4" x 6"	5	\$ -
1 1/4" x 7"	5	\$ -
1 1/4" x 8"	5	\$ -
1 1/4" x 9"	5	\$ -
1 1/4" x 10"	5	\$ -
1 1/4" x 11"	5	\$ -
1 1/4" x 12"	5	\$ -



<b>Galvanized</b>		
Size	Box Qty	List Price
1 1/4" x Close	5	\$ -
1 1/4" x 2"	5	\$ -
1 1/4" x 2 1/2"	5	\$ -
1 1/4" x 3"	5	\$ -
1 1/4" x 3 1/2"	5	\$ -
1 1/4" x 4"	5	\$ -
1 1/4" x 4 1/2"	5	\$ -
1 1/4" x 5"	5	\$ -
1 1/4" x 5 1/2"	5	\$ -
1 1/4" x 6"	5	\$ -
1 1/4" x 7"	5	\$ -
1 1/4" x 8"	5	\$ -
1 1/4" x 9"	5	\$ -
1 1/4" x 10"	5	\$ -
1 1/4" x 11"	5	\$ -
1 1/4" x 12"	5	\$ -

<b>Black</b>		
Size	Box Qty	List Price
1 1/2" x Close	5	\$ -
1 1/2" x 2"	5	\$ -
1 1/2" x 2 1/2"	5	\$ -
1 1/2" x 3"	5	\$ -
1 1/2" x 3 1/2"	5	\$ -
1 1/2" x 4"	5	\$ -
1 1/2" x 4 1/2"	5	\$ -
1 1/2" x 5"	5	\$ -
1 1/2" x 5 1/2"	5	\$ -
1 1/2" x 6"	5	\$ -
1 1/2" x 7"	5	\$ -
1 1/2" x 8"	5	\$ -
1 1/2" x 9"	5	\$ -
1 1/2" x 10"	5	\$ -
1 1/2" x 11"	5	\$ -
1 1/2" x 12"	5	\$ -



<b>Galvanized</b>		
Size	Box Qty	List Price
1 1/2" x Close	5	\$ -
1 1/2" x 2"	5	\$ -
1 1/2" x 2 1/2"	5	\$ -
1 1/2" x 3"	5	\$ -
1 1/2" x 3 1/2"	5	\$ -
1 1/2" x 4"	5	\$ -
1 1/2" x 4 1/2"	5	\$ -
1 1/2" x 5"	5	\$ -
1 1/2" x 5 1/2"	5	\$ -
1 1/2" x 6"	5	\$ -
1 1/2" x 7"	5	\$ -
1 1/2" x 8"	5	\$ -
1 1/2" x 9"	5	\$ -
1 1/2" x 10"	5	\$ -
1 1/2" x 11"	5	\$ -
1 1/2" x 12"	5	\$ -

### Steel Pipe Nipples - Sch 40

<b>Black</b>		
Size	Box Qty	List Price
2" x Close	5	\$ -
2" x 2 1/2"	5	\$ -
2" x 3"	5	\$ -
2" x 3 1/2"	5	\$ -
2" x 4"	5	\$ -
2" x 4 1/2"	5	\$ -
2" x 5"	5	\$ -
2" x 5 1/2"	5	\$ -
2" x 6"	5	\$ -
2" x 7"	5	\$ -
2" x 8"	5	\$ -
2" x 9"	5	\$ -
2" x 10"	5	\$ -
2" x 11"	5	\$ -
2" x 12"	5	\$ -
2" x 24"	-	\$ -
2" x 36"	-	\$ -
2" x 48"	-	\$ -
2" x 60"	-	\$ -
2" x 72"	-	\$ -



<b>Galvanized</b>		
Size	Box Qty	List Price
2" x Close	5	\$ -
2" x 2 1/2"	5	\$ -
2" x 3"	5	\$ -
2" x 3 1/2"	5	\$ -
2" x 4"	5	\$ -
2" x 4 1/2"	5	\$ -
2" x 5"	5	\$ -
2" x 5 1/2"	5	\$ -
2" x 6"	5	\$ -
2" x 7"	5	\$ -
2" x 8"	5	\$ -
2" x 9"	5	\$ -
2" x 10"	5	\$ -
2" x 11"	5	\$ -
2" x 12"	5	\$ -
2" x 24"	-	\$ -
2" x 36"	-	\$ -
2" x 48"	-	\$ -
2" x 60"	-	\$ -
2" x 72"	-	\$ -

<b>Black</b>		
Size	Box Qty	List Price
2 1/2" x Close	5	\$ -
2 1/2" x 3"	5	\$ -
2 1/2" x 3 1/2"	5	\$ -
2 1/2" x 4"	5	\$ -
2 1/2" x 4 1/2"	5	\$ -
2 1/2" x 5"	5	\$ -
2 1/2" x 5 1/2"	5	\$ -
2 1/2" x 6"	5	\$ -
2 1/2" x 7"	5	\$ -
2 1/2" x 8"	5	\$ -
2 1/2" x 9"	5	\$ -
2 1/2" x 10"	5	\$ -
2 1/2" x 11"	5	\$ -
2 1/2" x 12"	5	\$ -
2 1/2" x 24"	-	\$ -
2 1/2" x 36"	-	\$ -
2 1/2" x 48"	-	\$ -



<b>Galvanized</b>		
Size	Box Qty	List Price
2 1/2" x Close	5	\$ -
2 1/2" x 3"	5	\$ -
2 1/2" x 3 1/2"	5	\$ -
2 1/2" x 4"	5	\$ -
2 1/2" x 4 1/2"	5	\$ -
2 1/2" x 5"	5	\$ -
2 1/2" x 5 1/2"	5	\$ -
2 1/2" x 6"	5	\$ -
2 1/2" x 7"	5	\$ -
2 1/2" x 8"	5	\$ -
2 1/2" x 9"	5	\$ -
2 1/2" x 10"	5	\$ -
2 1/2" x 11"	5	\$ -
2 1/2" x 12"	5	\$ -
2 1/2" x 24"	-	\$ -
2 1/2" x 36"	-	\$ -
2 1/2" x 48"	-	\$ -



### Steel Pipe Nipples - Sch 40

<b>Black</b>		
Size	Box Qty	List Price
3" x Close	5	\$ -
3" x 3"	-	\$ -
3" x 3 1/2"	5	\$ -
3" x 4"	5	\$ -
3" x 4 1/2"	5	\$ -
3" x 5"	5	\$ -
3" x 5 1/2"	5	\$ -
3" x 6"	5	\$ -
3" x 7"	5	\$ -
3" x 8"	5	\$ -
3" x 9"	5	\$ -
3" x 10"	5	\$ -
3" x 11"	-	\$ -
3" x 12"	-	\$ -
3" x 24"	-	\$ -
3" x 36"	-	\$ -
3" x 48"	-	\$ -
3" x 60"	-	\$ -
3" x 72"	-	\$ -



<b>Galvanized</b>		
Size	Box Qty	List Price
3" x Close	5	\$ -
3" x 3"	5	\$ -
3" x 3 1/2"	5	\$ -
3" x 4"	5	\$ -
3" x 4 1/2"	5	\$ -
3" x 5"	5	\$ -
3" x 5 1/2"	5	\$ -
3" x 6"	5	\$ -
3" x 7"	5	\$ -
3" x 8"	5	\$ -
3" x 9"	5	\$ -
3" x 10"	5	\$ -
3" x 11"	5	\$ -
3" x 12"	5	\$ -
3" x 24"	-	\$ -
3" x 36"	-	\$ -
3" x 48"	-	\$ -
3" x 60"	-	\$ -
3" x 72"	-	\$ -

<b>Black</b>		
Size	Box Qty	List Price
4" x Close	5	\$ -
4" x 4"	5	\$ -
4" x 4 1/2"	5	\$ -
4" x 5"	5	\$ -
4" x 5 1/2"	5	\$ -
4" x 6"	5	\$ -
4" x 7"	5	\$ -
4" x 8"	5	\$ -
4" x 9"	5	\$ -
4" x 10"	5	\$ -
4" x 11"	5	\$ -
4" x 12"	5	\$ -
4" x 24"	-	\$ -
4" x 36"	-	\$ -
4" x 48"	-	\$ -
4" x 60"	-	\$ -
4" x 72"	-	\$ -



<b>Galvanized</b>		
Size	Box Qty	List Price
4" x Close	5	\$ -
4" x 4"	5	\$ -
4" x 4 1/2"	5	\$ -
4" x 5"	5	\$ -
4" x 5 1/2"	5	\$ -
4" x 6"	5	\$ -
4" x 7"	5	\$ -
4" x 8"	5	\$ -
4" x 9"	5	\$ -
4" x 10"	5	\$ -
4" x 11"	5	\$ -
4" x 12"	5	\$ -
4" x 24"	-	\$ -
4" x 36"	-	\$ -
4" x 48"	-	\$ -
4" x 60"	-	\$ -
4" x 72"	-	\$ -

### Steel Pipe Nipples - Sch 40

<b>Black</b>		
Size	Box Qty	List Price
5" x Close	10	\$ -
5" x 4"	6	\$ -
5" x 5"	4	\$ -
5" x 6"	4	\$ -
5" x 8"	3	\$ -
5" x 10"	3	\$ -
5" x 11"	-	\$ -
5" x 12"	-	\$ -



<b>Galvanized</b>		
Size	Box Qty	List Price
5" x Close	10	\$ -
5" x 4"	6	\$ -
5" x 5"	-	\$ -
5" x 6"	4	\$ -
5" x 8"	3	\$ -
5" x 10"	-	\$ -
5" x 11"	-	\$ -
5" x 12"	3	\$ -

<b>Black</b>		
Size	Box Qty	List Price
6" x Close	9	\$ -
6" x 4"	6	\$ -
6" x 5"	4	\$ -
6" x 6"	4	\$ -
6" x 7"	2	\$ -
6" x 8"	2	\$ -
6" x 9"	2	\$ -
6" x 10"	2	\$ -
6" x 12"	2	\$ -



<b>Galvanized</b>		
Size	Box Qty	List Price
6" x Close	9	\$ -
6" x 4"	6	\$ -
6" x 5"	-	\$ -
6" x 6"	4	\$ -
6" x 7"	2	\$ -
6" x 8"	2	\$ -
6" x 9"	-	\$ -
6" x 10"	2	\$ -
6" x 12"	2	\$ -

**125# CAST IRON THREADED COMPANION FLANGES**

Size (NPT)	OD	Hole Count	Bolt Hole Diameter	A (Min)	B	C	B.C	List Price
1-1/2"	5"	4	0.62"	0.56"	0.9"	2.56"	3.88"	\$ -
2"	6"	4	0.75"	0.62"	1.0"	3.06"	4.75"	\$ -
2-1/2"	7"	4	0.75"	0.69"	1.1"	3.56"	5.50"	\$ -
3"	7-1/2"	4	0.75"	0.75"	1.2"	4.25"	6.00"	\$ -
4"	9"	8	0.75"	0.94"	1.3"	5.31"	7.50"	\$ -
5"	10"	8	0.88"	0.94"	1.4"	6.44"	8.50"	\$ -
6"	11"	8	0.88"	1.00"	1.6"	7.56"	9.50"	\$ -
8"	13-1/2"	8	0.88"	1.12"	1.8"	9.69"	11.80"	\$ -
10"	16"	12	1.00"	1.19"	1.9"	11.90"	14.30"	\$ -
12"	19"	12	1.00"	1.25"	2.2"	14.10"	17.00"	\$ -

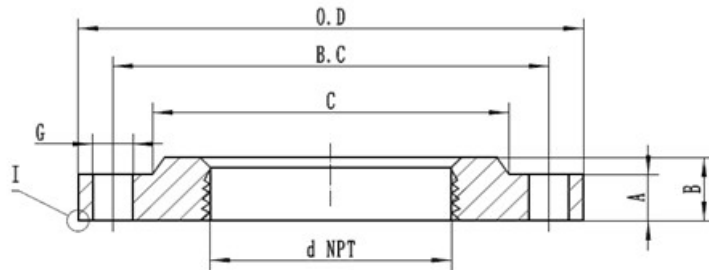

**FULL FACE FLANGE GASKET**

**Non-Asbestos (Green)**

Size	Hole Count	List Price
1-1/2" x 5"	4	\$ -
2" x 6"	4	\$ -
2-1/2" x 7"	4	\$ -
3" x 7-1/2"	4	\$ -
4" x 9"	8	\$ -
5" x 10"	8	\$ -
6" x 11"	8	\$ -
8" x 13-1/2"	8	\$ -
10" x 16"	12	\$ -
12" x 19"	12	\$ -

**Red Rubber**

Size	Hole Count	List Price
1-1/2" x 5"	4	\$ -
2" x 6"	4	\$ -
2-1/2" x 7"	4	\$ -
3" x 7-1/2"	4	\$ -
4" x 9"	8	\$ -
5" x 10"	8	\$ -
6" x 11"	8	\$ -
8" x 13-1/2"	8	\$ -
10" x 16"	12	\$ -
12" x 19"	12	\$ -

**GROOVED FITTINGS**

<u>MPN</u>	<u>DESCRIPTION</u>	<u>LIST</u>
<b>Sch. 40 Groove X Groove Nipples</b>		
K570200-4.0	2" X 4" Groove X Groove Black Steel Nipple	\$ -
K570300-4.0	3" X 4" Groove X Groove Black Steel Nipple	\$ -
K570400-6.0	4" X 6" Groove X Groove Black Steel Nipple	\$ -
K570600-12.0	6" X 12" Groove X Groove Black Steel Nipple	\$ -
K570800-12.0	8" X 12" Groove X Groove Black Steel Nipple	\$ -
K571000-12.0	10" X 12" Groove X Groove Black Steel Nipple	\$ -
K571200-12.0	12" X 12" Groove X Groove Black Steel Nipple	\$ -

<b>Sch. 40 Groove X Thread Nipples</b>		
K590200-4.0	2" X 4" Groove X Thread Black Steel Nipple	\$ -
K590300-4.0	3" X 4" Groove X Thread Black Steel Nipple	\$ -
K590400-6.0	4" X 6" Groove X Thread Black Steel Nipple	\$ -

<b>Grooved Pipe Flex Coupling</b>		
K050200PE	2" Grooved Pipe Flex Coupling	\$ -
K050300PE	3" Grooved Pipe Flex Coupling	\$ -
K050400PE	4" Grooved Pipe Flex Coupling	\$ -
K050600PE	6" Grooved Pipe Flex Coupling	\$ -
K050800PE	8" Grooved Pipe Flex Coupling	\$ -
K051000PE	10" Grooved Pipe Flex Coupling	\$ -
K051200PE	12" Grooved Pipe Flex Coupling	\$ -

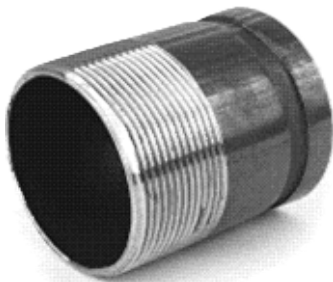

**STAINLESS STEEL FITTINGS**

**SS 90° ELBOW**

Size	Box Qty	List Price
1/4"	100	\$ -
3/8"	50	\$ -
1/2"	30	\$ -
3/4"	18	\$ -
1"	10	\$ -
1 1/4"	16	\$ -
1 1/2"	12	\$ -
2"	8	\$ -
2 1/2"	6	\$ -
3"	3	\$ -
4"	2	\$ -



**SS 90° STREET ELBOW**

Size	Box Qty	List Price
1/4"	100	\$ -
3/8"	50	\$ -
1/2"	32	\$ -
3/4"	12	\$ -
1"	8	\$ -
1 1/4"	16	\$ -
1 1/2"	4	\$ -
2"	8	\$ -
2 1/2"	4	\$ -
3"	3	\$ -
4"	2	\$ -



**SS 45° ELBOW**

Size	Box Qty	List Price
1/4"	100	\$ -
3/8"	60	\$ -
1/2"	30	\$ -
3/4"	20	\$ -
1"	8	\$ -
1 1/4"	6	\$ -
1 1/2"	12	\$ -
2"	8	\$ -
2 1/2"	6	\$ -
3"	4	\$ -
4"	2	\$ -



**SS TEE**

Size	Box Qty	List Price
1/4"	70	\$ -
3/8"	40	\$ -
1/2"	15	\$ -
3/4"	12	\$ -
1"	24	\$ -
1 1/4"	20	\$ -
1 1/2"	12	\$ -
2"	9	\$ -
2 1/2"	5	\$ -
3"	2	\$ -
4"	-	\$ -



**SS SQUARE HEAD PLUG**

Size	Box Qty	List Price
1/4"	350	\$ -
3/8"	250	\$ -
1/2"	100	\$ -
3/4"	60	\$ -
1"	36	\$ -
1 1/4"	28	\$ -
1 1/2"	24	\$ -
2"	36	\$ -
2 1/2"	20	\$ -
3"	12	\$ -
4"	10	\$ -



**SS CAP**

Size	Box Qty	List Price
1/4"	150	\$ -
3/8"	80	\$ -
1/2"	60	\$ -
3/4"	40	\$ -
1"	18	\$ -
1 1/4"	12	\$ -
1 1/2"	9	\$ -
2"	16	\$ -
2 1/2"	15	\$ -
3"	12	\$ -
4"	4	\$ -



**STAINLESS STEEL FITTINGS**

**SS BUSHING**

Size	Box Qty	List Price
1/4" x 1/8"	300	\$ -
3/8" x 1/4"	120	\$ -
1/2" x 1/4"	100	\$ -
1/2" x 3/8"	100	\$ -
3/4" x 1/4"	60	\$ -
3/4" x 3/8"	60	\$ -
3/4" x 1/2"	60	\$ -
1" x 1/4"	36	\$ -
1" x 3/8"	36	\$ -
1" x 1/2"	36	\$ -
1" x 3/4"	36	\$ -
1 1/4" x 1/2"	18	\$ -
1 1/4" x 3/4"	18	\$ -
1 1/4" x 1"	18	\$ -
1 1/2" x 1/2"	18	\$ -
1 1/2" x 3/4"	18	\$ -
1 1/2" x 1"	18	\$ -
1 1/2" x 1 1/4"	18	\$ -
2" x 1/2"	9	\$ -
2" x 3/4"	9	\$ -
2" x 1"	9	\$ -
2" x 1 1/4"	9	\$ -
2" x 1 1/2"	9	\$ -
2 1/2" x 1"	16	\$ -
2 1/2" x 1 1/4"	16	\$ -
2 1/2" x 1 1/2"	16	\$ -
2 1/2" x 2"	16	\$ -
3" x 1"	12	\$ -
3" x 1 1/2"	12	\$ -
3" x 2"	12	\$ -
3" x 2 1/2"	12	\$ -
4" x 1 1/2"	4	\$ -
4" x 2"	4	\$ -
4" x 3"	4	\$ -



**SS REDUCER COUPLING**

Size	Box Qty	List Price
1/4" x 1/8"	150	\$ -
3/8" x 1/4"	60	\$ -
1/2" x 1/4"	40	\$ -
1/2" x 3/8"	40	\$ -
3/4" x 1/4"	24	\$ -
3/4" x 3/8"	24	\$ -
3/4" x 1/2"	24	\$ -
1" x 1/4"	12	\$ -
1" x 3/8"	12	\$ -
1" x 1/2"	12	\$ -
1" x 3/4"	12	\$ -
1 1/4" x 1/2"	12	\$ -
1 1/4" x 3/4"	12	\$ -
1 1/4" x 1"	12	\$ -
1 1/2" x 1/2"	8	\$ -
1 1/2" x 3/4"	8	\$ -
1 1/2" x 1"	8	\$ -
1 1/2" x 1 1/4"	8	\$ -
2" x 1/2"	16	\$ -
2" x 3/4"	16	\$ -
2" x 1"	16	\$ -
2" x 1 1/4"	16	\$ -
2" x 1 1/2"	16	\$ -
2 1/2" x 1"	-	\$ -
2 1/2" x 1 1/4"	-	\$ -
2 1/2" x 1 1/2"	16	\$ -
2 1/2" x 2"	9	\$ -
3" x 1"	9	\$ -
3" x 1 1/2"	9	\$ -
3" x 2"	9	\$ -
3" x 2 1/2"	-	\$ -
4" x 1 1/2"	-	\$ -
4" x 2"	3	\$ -
4" x 3"	3	\$ -



**STAINLESS STEEL FITTINGS**

**SS UNION**

Size	Box Qty	List Price
1/4"	45	\$ -
3/8"	24	\$ -
1/2"	16	\$ -
3/4"	12	\$ -
1"	8	\$ -
1 1/4"	16	\$ -
1 1/2"	8	\$ -
2"	8	\$ -
2 1/2"	8	\$ -
3"	4	\$ -
4"	2	\$ -



**SS MERCHANT COUPLING**

Size	Box Qty	List Price
1/4"	120	\$ -
3/8"	100	\$ -
1/2"	60	\$ -
3/4"	30	\$ -
1"	16	\$ -
1 1/4"	12	\$ -
1 1/2"	12	\$ -
2"	16	\$ -
2 1/2"	8	\$ -
3"	6	\$ -
4"	3	\$ -



**SS DROP PIPE COUPLING**

Size	Box Qty	List Price
1"	10	\$ -
1 1/4"	10	\$ -
1 1/2"	10	\$ -
2"	5	\$ -



**SS INSERT MALE ADAPTER**

Size	Box Qty	List Price
3/4"	20	\$ -
1"	20	\$ -
1 1/4"	20	\$ -
1 1/2"	10	\$ -
2"	5	\$ -



**1/8" SS NIPPLE**

Size	Box Qty	List Price
1/8" x Close	25	\$ -
1/8" x 1 1/2"	25	\$ -
1/8" x 2"	25	\$ -
1/8" x 2 1/2"	25	\$ -
1/8" x 3"	25	\$ -
1/8" x 3 1/2"	25	\$ -
1/8" x 4"	25	\$ -
1/8" x 4 1/2"	25	\$ -
1/8" x 5"	25	\$ -
1/8" x 5 1/2"	25	\$ -
1/8" x 6"	25	\$ -
1/8" x 8"	25	\$ -
1/8" x 10"	25	\$ -
1/8" x 12"	25	\$ -



**1/4" SS NIPPLE**

Size	Box Qty	List Price
1/4" x Close	25	\$ -
1/4" x 1 1/2"	25	\$ -
1/4" x 2"	25	\$ -
1/4" x 2 1/2"	25	\$ -
1/4" x 3"	25	\$ -
1/4" x 3 1/2"	25	\$ -
1/4" x 4"	25	\$ -
1/4" x 4 1/2"	25	\$ -
1/4" x 5"	25	\$ -
1/4" x 5 1/2"	25	\$ -
1/4" x 6"	25	\$ -
1/4" x 8"	25	\$ -
1/4" x 10"	25	\$ -
1/4" x 12"	25	\$ -



**STAINLESS STEEL FITTINGS**

**3/8" SS NIPPLE**

Size	Box Qty	List Price
3/8" x Close	25	\$ -
3/8" x 1 1/2"	25	\$ -
3/8" x 2"	25	\$ -
3/8" x 2 1/2"	25	\$ -
3/8" x 3"	25	\$ -
3/8" x 3 1/2"	25	\$ -
3/8" x 4"	25	\$ -
3/8" x 4 1/2"	25	\$ -
3/8" x 5"	25	\$ -
3/8" x 5 1/2"	25	\$ -
3/8" x 6"	25	\$ -
3/8" x 7"	-	\$ -
3/8" x 8"	25	\$ -
3/8" x 9"	-	\$ -
3/8" x 10"	25	\$ -
3/8" x 11"	-	\$ -
3/8" x 12"	25	\$ -



**1/2" SS NIPPLE**

Size	Box Qty	List Price
1/2" x Close	25	\$ -
1/2" x 1 1/2"	25	\$ -
1/2" x 2"	25	\$ -
1/2" x 2 1/2"	25	\$ -
1/2" x 3"	25	\$ -
1/2" x 3 1/2"	25	\$ -
1/2" x 4"	25	\$ -
1/2" x 4 1/2"	25	\$ -
1/2" x 5"	25	\$ -
1/2" x 5 1/2"	25	\$ -
1/2" x 6"	25	\$ -
1/2" x 7"	25	\$ -
1/2" x 8"	25	\$ -
1/2" x 9"	25	\$ -
1/2" x 10"	25	\$ -
1/2" x 11"	25	\$ -
1/2" x 12"	25	\$ -



**3/4" SS NIPPLE**

Size	Box Qty	List Price
3/4" x Close	25	\$ -
3/4" x 1 1/2"	25	\$ -
3/4" x 2"	25	\$ -
3/4" x 2 1/2"	25	\$ -
3/4" x 3"	25	\$ -
3/4" x 3 1/2"	25	\$ -
3/4" x 4"	25	\$ -
3/4" x 4 1/2"	25	\$ -
3/4" x 5"	25	\$ -
3/4" x 5 1/2"	25	\$ -
3/4" x 6"	25	\$ -
3/4" x 7"	25	\$ -
3/4" x 8"	25	\$ -
3/4" x 9"	25	\$ -
3/4" x 10"	25	\$ -
3/4" x 11"	25	\$ -
3/4" x 12"	25	\$ -



**1" SS NIPPLE**

Size	Box Qty	List Price
1" x Close	25	\$ -
1" x 1 1/2"	-	\$ -
1" x 2"	25	\$ -
1" x 2 1/2"	25	\$ -
1" x 3"	25	\$ -
1" x 3 1/2"	25	\$ -
1" x 4"	25	\$ -
1" x 4 1/2"	25	\$ -
1" x 5"	25	\$ -
1" x 5 1/2"	25	\$ -
1" x 6"	25	\$ -
1" x 7"	10	\$ -
1" x 8"	10	\$ -
1" x 9"	10	\$ -
1" x 10"	10	\$ -
1" x 11"	10	\$ -
1" x 12"	10	\$ -





**STAINLESS STEEL FITTINGS**

**1 1/4" SS NIPPLE**

Size	Box Qty	List Price
1 1/4" x Close	5	\$ -
1 1/4" x 2"	5	\$ -
1 1/4" x 2 1/2"	5	\$ -
1 1/4" x 3"	5	\$ -
1 1/4" x 3 1/2"	5	\$ -
1 1/4" x 4"	5	\$ -
1 1/4" x 4 1/2"	5	\$ -
1 1/4" x 5"	5	\$ -
1 1/4" x 5 1/2"	5	\$ -
1 1/4" x 6"	5	\$ -
1 1/4" x 7"	5	\$ -
1 1/4" x 8"	5	\$ -
1 1/4" x 9"	5	\$ -
1 1/4" x 10"	5	\$ -
1 1/4" x 11"	5	\$ -
1 1/4" x 12"	5	\$ -



**1 1/2" SS NIPPLE**

Size	Box Qty	List Price
1 1/2" x Close	5	\$ -
1 1/2" x 2"	5	\$ -
1 1/2" x 2 1/2"	5	\$ -
1 1/2" x 3"	5	\$ -
1 1/2" x 3 1/2"	5	\$ -
1 1/2" x 4"	5	\$ -
1 1/2" x 4 1/2"	5	\$ -
1 1/2" x 5"	5	\$ -
1 1/2" x 5 1/2"	5	\$ -
1 1/2" x 6"	5	\$ -
1 1/2" x 7"	5	\$ -
1 1/2" x 8"	5	\$ -
1 1/2" x 9"	5	\$ -
1 1/2" x 10"	5	\$ -
1 1/2" x 11"	5	\$ -
1 1/2" x 12"	5	\$ -



**2" SS NIPPLE**

Size	Box Qty	List Price
2" x Close	5	\$ -
2" x 2 1/2"	5	\$ -
2" x 3"	5	\$ -
2" x 3 1/2"	5	\$ -
2" x 4"	5	\$ -
2" x 4 1/2"	5	\$ -
2" x 5"	5	\$ -
2" x 5 1/2"	5	\$ -
2" x 6"	5	\$ -
2" x 7"	5	\$ -
2" x 8"	5	\$ -
2" x 9"	5	\$ -
2" x 10"	5	\$ -
2" x 11"	5	\$ -
2" x 12"	5	\$ -



**2 1/2" SS NIPPLE**

Size	Box Qty	List Price
2 1/2" x Close	35	\$ -
2 1/2" x 2 1/2"	-	\$ -
2 1/2" x 3"	35	\$ -
2 1/2" x 3 1/2"	25	\$ -
2 1/2" x 4"	25	\$ -
2 1/2" x 4 1/2"	25	\$ -
2 1/2" x 5"	20	\$ -
2 1/2" x 5 1/2"	20	\$ -
2 1/2" x 6"	20	\$ -
2 1/2" x 7"	-	\$ -
2 1/2" x 8"	15	\$ -
2 1/2" x 9"	-	\$ -
2 1/2" x 10"	10	\$ -
2 1/2" x 11"	-	\$ -
2 1/2" x 12"	10	\$ -



**STAINLESS STEEL FITTINGS**

**3" SS NIPPLE**

Size	Box Qty	List Price
3" x Close	25	\$ -
3" x 3"	25	\$ -
3" x 3 1/2"	20	\$ -
3" x 4"	20	\$ -
3" x 4 1/2"	15	\$ -
3" x 5"	15	\$ -
3" x 5 1/2"	15	\$ -
3" x 6"	15	\$ -
3" x 8"	10	\$ -
3" x 10"	10	\$ -
3" x 12"	10	\$ -



**4" SS NIPPLE**

Size	Box Qty	List Price
4" x Close	15	\$ -
4" x 3"	-	\$ -
4" x 3 1/2"	-	\$ -
4" x 4"	15	\$ -
4" x 4 1/2"	10	\$ -
4" x 5"	10	\$ -
4" x 5 1/2"	-	\$ -
4" x 6"	10	\$ -
4" x 8"	5	\$ -
4" x 10"	5	\$ -
4" x 12"	5	\$ -



**BRASS FITTINGS**

**BRASS 90° ELBOW**

Size	Box Qty	List Price
1/4"	35	\$ -
3/4"	35	\$ -
1"	20	\$ -
1 1/4"	20	\$ -
2"	8	\$ -



**BRASS 90° STREET ELBOW**

Size	Box Qty	List Price
1/4"	35	\$ -
3/4"	35	\$ -
1"	45	\$ -
1 1/4"	25	\$ -
2"	8	\$ -



**BRASS TEE**

Size	Box Qty	List Price
1/4"	75	\$ -
3/4"	35	\$ -
1"	20	\$ -
1 1/4"	14	\$ -
2"	8	\$ -



**1/4" BRASS NIPPLE**

Size	Box Qty	List Price
1/4" X CLOSE	25	\$ -
1/4" X 3"	25	\$ -
1/4" X 4"	25	\$ -
1/4" X 6"	25	\$ -
1/4" X 8"	25	\$ -



**1" BRASS NIPPLE**

Size	Box Qty	List Price
1" X CLOSE	25	\$ -
1" X 4"	25	\$ -
1" X 6"	25	\$ -
1" X 8"	10	\$ -
1" X 12"	10	\$ -



**1 1/4" BRASS NIPPLE**

Size	Box Qty	List Price
1 1/4" X CLOSE	5	\$ -
1 1/4" X 4"	5	\$ -
1 1/4" X 6"	5	\$ -
1 1/4" X 8"	5	\$ -
1 1/4" X 12"	5	\$ -



**PIPE THREAD COMPOUND**

Product Description	Size	List Price
Talon PTFE Thread Compound	1/4 Pint	\$ -
Talon PTFE Thread Compound	Pint	\$ -
Talon PTFE Thread Compound	Quart	\$ -



*TALON PTFE\* Pipe Thread Compound is a triple lubricating, all-purpose, non-seizing, industrial grade thread sealing compound that provides **Freedom from Leaks™** on all types of metal and plastic threaded connections (except ABS).*

Blue Magic Thread Compound	1/4 Pint	\$ -
Blue Magic Thread Compound	1/2 Pint	\$ -
Blue Magic Thread Compound	Pint	\$ -
Blue Magic Thread Compound	Quart	\$ -



*BLUE MAGIC is an All Purpose, Non-seizing, Industrial Grade Pipe Thread Compound that produces a leakproof seal on all types of metal and plastic threaded connections. Suitable for ABS, PVC, and CPVC threaded connections. MADE IN THE U.S.A.*

- Non-Separating
- Grit Free Paste
- Adheres to Oily Threads
- Non Combustible
- Safe for PVC & CPVC
- Nontoxic
- Superior Anti-Galling Properties
- Excellent for Stainless Connections

Product Description	Size	List Price
Stinger HDD White Non-Metalic	1 Gallon	\$ -
Stinger HDD White Non-Metalic	2 Gallon	\$ -
Stinger HDD White Non-Metalic	5 Gallon	\$ -
Stinger Water Well Copper Based	1 Gallon	\$ -
Stinger Water Well Copper Based	3.5 Gallon	\$ -
Stinger Water Well Copper Based	5 Gallon	\$ -
ZN-18	2 Gallon	\$ -
ZN-18	5 Gallon	\$ -



Taper Dope Brush	\$ -
Beveled Dope Brush	\$ -
Mustache Brush	\$ -



**BESTOLIFE**  
PREMIUM COMPOUNDS

*Applies Like Honey.  
Works Like a Bee.*

## VALVES

<b>Section</b>	<b>Page</b>
Flomatic Check Valves	E-1
Simmons Check Valves	E-5
Swing Check Valves	E-6
Gate Valves	E-6
Ball Valves	E-6
Butterfly Valves	E-6
Flow Control Valves	E-7
Cycle Gard Valves	E-8
Bury Hydrant	E-9
Air Vents	E-9
D&K Clearview Couplings	E-10
D&K Sight Checks	E-10

**FLOMATIC ENVIRO CHECK VALVES**

	Mfg Part Number	Size	Connections	Taps	Tap Sizes	List Price
<b>80E Brass Fromatic Check Valve</b>	4031E	1"	FxF	No Tap	None	\$ -
	4032E	1¼"	FxF	No Tap	None	\$ -
	4033E	1½"	FxF	No Tap	None	\$ -
	4034E	2"	FxF	No Tap	None	\$ -
	4035E	2½"	FxF	No Tap	None	\$ -
	4036E	3"	FxF	No Tap	None	\$ -
	4037E	4"	FxF	No Tap	None	\$ -
<b>100E Brass Fromatic Check Valve</b>	4201LE*	1"	FxF	No Tap	None	\$ -
	4202E	1¼"	FxF	No Tap	None	\$ -
<i>* Longer Threads</i>						
<b>100ME Brass Fromatic Check Valve</b>	4221LE*	1¼" M x 1" F		No Tap	None	\$ -
	4242E	1¼" M x 1¼" F		No Tap	None	\$ -
	4079E	2" M x 2" F		No Tap	None	\$ -
<i>* Longer Threads</i>						
<b>80BE Brass Fromatic Check Valve</b>	4051E	1"	FxF	2 Tap	⅜" In ¼" Out	\$ -
	4052E	1¼"	FxF	2 Tap	⅜" In ¼" Out	\$ -
	4053E	1½"	FxF	2 Tap	⅜" In ¼" Out	\$ -
	4054E	2"	FxF	2 Tap	⅜" In ¼" Out	\$ -





**FLOMATIC ENVIRO CHECK VALVES**

	Mfg Part Number	Size	Connections	Taps	Tap Sizes	List Price
<b>80EVFD</b> <b>Brass Flomatic</b> <b>Check Valve</b>	4031EVFD	1"	FxF	No Tap	None	\$ -
	4032EVFD	1¼"	FxF	No Tap	None	\$ -
	4033EVFD	1½"	FxF	No Tap	None	\$ -
	4034EVFD	2"	FxF	No Tap	None	\$ -
	4035EVFD	2½"	FxF	No Tap	None	\$ -
	4036EVFD	3"	FxF	No Tap	None	\$ -
	4037EVFD	4"	FxF	No Tap	None	\$ -
<b>100EVFD</b> <b>Brass Flomatic</b> <b>Check Valve</b>	4201ESVFD	1"	FxF	No Tap	None	\$ -
	4202ESVFD	1¼"	FxF	No Tap	None	\$ -
<b>100MEVFD</b> <b>Brass Flomatic</b> <b>Check Valve</b>	4071EVFD	1" M x 1" F		No Tap	None	\$ -
	4221LEFVD	1¼" M x 1" F		No Tap	None	\$ -
	4242EVFD	1¼" M x 1¼" F		No Tap	None	\$ -
<b>80BEVFD</b> <b>Brass Flomatic</b> <b>Check Valve</b>	4051EVFD	1"	FxF	2 Tap	⅛" In ¼" Out	\$ -
	4052EVFD	1¼"	FxF	2 Tap	⅛" In ¼" Out	\$ -
	4053EVFD	1½"	FxF	2 Tap	⅛" In ¼" Out	\$ -
<b>80XBEVFD</b> <b>Brass Flomatic</b> <b>Check Valve</b>	7961EVFD	1"	FxF	2 Tap	¼" Out ¼" Out	\$ -
	7962EVFD	1¼"	FxF	2 Tap	¼" Out ¼" Out	\$ -
	7964EVFD	1½"	FxF	2 Tap	¼" Out ¼" Out	\$ -





**FLOMATIC STAINLESS STEEL CHECK VALVES**

	Mfg Part Number	Size	Connections	Taps	Tap Sizes	List Price
<b>80SS</b>	4031SS2	1"	FxF	No Tap	None	\$ -
<b>Stainless Steel</b>	4032SS2	1¼"	FxF	No Tap	None	\$ -
<b>Flomatic Check</b>	4033SS2	1½"	FxF	No Tap	None	\$ -
<b>Valve</b>	4034SS2	2"	FxF	No Tap	None	\$ -



<b>100SSVFD</b>	4201SS2VFD	1"	FxF	No Tap	None	\$ -
<b>Stainless Steel</b>	4202SS2VFD	1¼"	FxF	No Tap	None	\$ -
<b>Flomatic Check</b>	4203SS2VFD	1½"	FxF	No Tap	None	\$ -
<b>Valve</b>						



<b>100MSSVFD</b>	4220SS2VFD	1" M x 1" F		No Tap	None	\$ -
<b>Stainless Steel</b>	4221SS2VFD	1¼" M x 1" F		No Tap	None	\$ -
<b>Flomatic Check</b>	4242SS2VFD	1¼" M x 1¼" F		No Tap	None	\$ -
<b>Valve</b>						



<b>80SSBVFD</b>	4051SS2VFD	1"	FxF	2 Tap	¼" In ¼" Out	\$ -
<b>Stainless Steel</b>	4052SS2VFD	1¼"	FxF	2 Tap	¼" In ¼" Out	\$ -
<b>Flomatic Check</b>	4053SS2VFD	1½"	FxF	2 Tap	¼" In ¼" Out	\$ -
<b>Valve</b>	4054SS2	2"	FxF	2 Tap	¼" In ¼" Out	\$ -



<b>80SSXBVFD</b>	7961SS2VFD	1"	FxF	2 Tap	¼" In ¼" Out	\$ -
<b>Stainless Steel</b>	7963SS2VFD	1¼"	FxF	2 Tap	¼" In ¼" Out	\$ -
<b>Flomatic Check</b>	7964SS2VFD	1½"	FxF	2 Tap	¼" In ¼" Out	\$ -
<b>Valve</b>						



**FLOMATIC CHECK VALVES**

	Mfg Part Number	Description	List Price
<b>80MDIVFD</b>	4083VFD	3" MxF 80MDIVFD Check Valve - Ductile Iron	\$ -
<b>Ductile Iron</b>	4077VFD	4" MxF 80MDIVFD Check Valve - Ductile Iron	\$ -
<b>Flomatic</b>	4075VFD	5" MxF 80MDIVFD Check Valve - Ductile Iron	\$ -
<b>Check Valve</b>	4081VFD	6" MxF 80MDIVFD Check Valve - Ductile Iron	\$ -
	7936	2½" FxF 80DI Check Valve - Ductile Iron	\$ -
<b>80DI</b>	7938	3" FxF 80DI Check Valve - Ductile Iron	\$ -
<b>Ductile Iron</b>	7939	4" FxF 80DI Check Valve - Ductile Iron	\$ -
<b>Flomatic</b>	4088	5" FxF 80DI Check Valve - Ductile Iron	\$ -
<b>Check Valve</b>	4089	6" FxF 80DI Check Valve - Ductile Iron	\$ -
	4090	8" FxF 80DI Check Valve - Ductile Iron	\$ -
<b>80DI</b>	7936PLG	2½" FxF 80DI Check Valve - Ductile Iron W-Break-Off Plug	\$ -
<b>Ductile Iron</b>	7938PLG	3" FxF 80DI Check Valve - Ductile Iron W-Break-Off Plug	\$ -
<b>Flomatic</b>	7939PLG	4" FxF 80DI Check Valve - Ductile Iron W-Break-Off Plug	\$ -
<b>Check Valve</b>	4088PLG	5" FxF 80DI Check Valve - Ductile Iron W-Break-Off Plug	\$ -
<b>With Break-Off Plug</b>	4089PLG	6" FxF 80DI Check Valve - Ductile Iron W-Break-Off Plug	\$ -
	4090PLG	8" FxF 80DI Check Valve - Ductile Iron W-Break-Off Plug	\$ -



**FLOMATIC REPLACEMENT BREAK-OFF PLUGS**

Mfg Part Number	Valve Size	Break-Off Plug Size	Construction	List Price
76098P	3" - 6"	3/8"	Composite	\$ -
76098P	2"	1/8"	Stainless Steel	\$ -
76098-2	2½"	3/8"	Stainless Steel	\$ -
76098-3	3"	3/8"	Stainless Steel	\$ -
76098-6	4"	3/8"	Stainless Steel	\$ -
76098-7	5"-6"	3/8"	Stainless Steel	\$ -
76098*	8"	1/2"	Stainless Steel	\$ -
76098-8	10" & 12"	1/2"	Stainless Steel	\$ -







**SIMMONS MFG CHECK VALVES**

	Mfg Part Number	Size	Connections	Taps	Tap Sizes	List Price
<b>500SB Series Simmons Mfg Check Valve</b>	513SB	1"	FxF	No Tap	None	\$ -
	514SB	1¼"	FxF	No Tap	None	\$ -
	505SB	1½"	FxF	No Tap	None	\$ -
	506SB	2"	FxF	No Tap	None	\$ -



<b>500SB Series Simmons Mfg 2 Tap Check Valve</b>	542SB	1"	MxF	2 Tap	⅝" In ¼" Out	\$ -
	543SB	1¼"	MxF	2 Tap	⅝" In ¼" Out	\$ -
	544SB	1½"	MxF	2 Tap	⅝" In ¼" Out	\$ -
	545SB	2"	MxF	2 Tap	⅝" In ¼" Out	\$ -



**SIMMONS MFG CHECK VALVES - DUCTILE IRON**

Mfg Part Number	Description	List Price
669SB	2½" FxF Simmons MFG Check Valve - Ductile Iron	\$ -
670SB	3" FxF Simmons MFG Check Valve - Ductile Iron	\$ -
671SB	4" FxF Simmons MFG Check Valve - Ductile Iron	\$ -
674SB	5" FxF Simmons MFG Check Valve - Ductile Iron	\$ -
672SB	6" FxF Simmons MFG Check Valve - Ductile Iron	\$ -
673SB	8" FxF Simmons MFG Check Valve - Ductile Iron	\$ -



668SB	2½" FxF Simmons MFG DI Check Valve - W/Breakoff Plug	\$ -
675SB	3" FxF Simmons MFG DI Check Valve - W/Breakoff Plug	\$ -
676SB	4" FxF Simmons MFG DI Check Valve - W/Breakoff Plug	\$ -
679SB	5" FxF Simmons MFG DI Check Valve - W/Breakoff Plug	\$ -
677SB	6" FxF Simmons MFG DI Check Valve - W/Breakoff Plug	\$ -
678SB	8" FxF Simmons MFG DI Check Valve - W/Breakoff Plug	\$ -



658SB	2" MxF Simmons MFG Check Valve - Ductile Iron	\$ -
660SB	3" MxF Simmons MFG Check Valve - Ductile Iron	\$ -
661SB	4" MxF Simmons MFG Check Valve - Ductile Iron	\$ -
662SB	6" MxF Simmons MFG Check Valve - Ductile Iron	\$ -



**BRASS GATE VALVES**

Size	Description	List Price
½"	Brass Gate Valve	\$ 7.80
¾"	Brass Gate Valve	\$ 11.00
1"	Brass Gate Valve	\$ 16.20
1¼"	Brass Gate Valve	\$ 22.80
1½"	Brass Gate Valve	\$ 28.90
2"	Brass Gate Valve	\$ 43.20
2½"	Brass Gate Valve	\$ 76.50
3"	Brass Gate Valve	\$ 96.00
4"	Brass Gate Valve	\$ 174.00



**BRASS BALL VALVES**

Size	Description	List Price
½"	Brass Ball Valve	\$ -
¾"	Brass Ball Valve	\$ -
1"	Brass Ball Valve	\$ -
1¼"	Brass Ball Valve	\$ -
1½"	Brass Ball Valve	\$ -
2"	Brass Ball Valve	\$ -
2½"	Brass Ball Valve	\$ -
3"	Brass Ball Valve	\$ -
4"	Brass Ball Valve	\$ -



**BRASS SWING CHECK VALVES**

Size	Description	List Price
1"	Brass Swing Check	\$ -
1¼"	Brass Swing Check	\$ -
1½"	Brass Swing Check	\$ -
2"	Brass Swing Check	\$ -
2½"	Brass Swing Check	\$ -
3"	Brass Swing Check	\$ -
4"	Brass Swing Check	\$ -



**PVC BALL VALVES**

Size	Description	List Price
½"	PVC Ball Valve	\$ -
¾"	PVC Ball Valve	\$ -
1"	PVC Ball Valve	\$ -
1¼"	PVC Ball Valve	\$ -
1½"	PVC Ball Valve	\$ -
2"	PVC Ball Valve	\$ -
2½"	PVC Ball Valve	\$ -
3"	PVC Ball Valve	\$ -
4"	PVC Ball Valve	\$ -



**DI HIGH PRESSURE SWING CHECK VALVES**

Size	Description	List Price
2"	Ductile Iron Swing Check	\$ -
3"	Ductile Iron Swing Check	\$ -
4"	Ductile Iron Swing Check	\$ -



**DI HIGH PRESSURE BALL VALVES**

Size	Description	List Price
2"	Ductile Iron Ball Valve	\$ -
3"	Ductile Iron Ball Valve	\$ -
4"	Ductile Iron Ball Valve	\$ -



**BUTTERFLY VALVES - LEVER**

Size	Description	List Price
2"	Lever - Butterfly Valve	\$ -
2½"	Lever - Butterfly Valve	\$ -
3"	Lever - Butterfly Valve	\$ -
4"	Lever - Butterfly Valve	\$ -
5"	Lever - Butterfly Valve	\$ -
6"	Lever - Butterfly Valve	\$ -
8"	Lever - Butterfly Valve	\$ -
10"	Lever - Butterfly Valve	\$ -
12"	Lever - Butterfly Valve	\$ -



**BUTTERFLY VALVES - GEAR**

Size	Description	List Price
2"	Gear - Butterfly Valve	\$ -
2½"	Gear - Butterfly Valve	\$ -
3"	Gear - Butterfly Valve	\$ -
4"	Gear - Butterfly Valve	\$ -
5"	Gear - Butterfly Valve	\$ -
6"	Gear - Butterfly Valve	\$ -
8"	Gear - Butterfly Valve	\$ -
10"	Gear - Butterfly Valve	\$ -
12"	Gear - Butterfly Valve	\$ -



**FLOW CONTROL VALVES**

**FLOMATIC FLO-TROL**

Model	Size	Connection	GPM	List Price
CDX1.0	1"	FxF	1	\$ -
CDX1.5	1"	FxF	1.5	\$ -
CDX2.0	1"	FxF	2	\$ -
CDX2.5	1"	FxF	2.5	\$ -
CDX3.0	1"	FxF	3	\$ -
CDX3.5	1"	FxF	3.5	\$ -
CDX4.0	1"	FxF	4	\$ -
CDX4.5	1"	FxF	4.5	\$ -
CDX5.0	1"	FxF	5	\$ -
CDX6.0	1"	FxF	6	\$ -
CDX7.0	1"	FxF	7	\$ -
CDX8.0	1"	FxF	8	\$ -
CDX9.0	1"	FxF	9	\$ -
CDX10	1"	FxF	10	\$ -
CDX12	1"	FxF	12	\$ -
CDX15	1"	FxF	15	\$ -
CDX17	1"	FxF	17	\$ -
CDX20	1"	FxF	20	\$ -
CDX25	1"	FxF	25	\$ -
CDX30	1"	FxF	30	\$ -

- \*Constant flow rates
- \*Booster pump systems
- \*Domestic water systems
- \*Sizes 3/8" thru 1-1/2" (.25 - 30 GPM)
- \*NSF/ANSI 61 and 372 Certified
- \*Stainless steel construction
- \*Laser engraved flow rate and size



**FLOMATIC CYCLE GARD VALVES**

**C153S6 Cycle Gard Constant Pressure Control Valve**

Description	GPM	PSI	List Price
1"F & 1¼"M Stainless Steel Cycle Gard	1-20	50	\$ -
1"F & 1¼"M Stainless Steel Cycle Gard	1-20	60	\$ -
1¼"F Stainless Steel Cycle Gard	1-50	50	\$ -
1¼"F Stainless Steel Cycle Gard	1-50	60	\$ -



**CB152ET Cycle Gard Constant Pressure Control Valve With Tappings**

Description	GPM	PSI	List Price
1"F & 1¼"M Unleaded Bronze Cycle Gard	1-25	15-75	\$ -
1"F & 1¼"M Unleaded Bronze Cycle Gard	1-25	15-150	\$ -



**CB152EHF Hy-Flow Cycle Gard Constant Pressure Control Valve**

Description	GPM	PSI	List Price
1¼"F Unleaded Bronze Cycle Gard	5-70	15-75	\$ -
1¼"F Unleaded Bronze Cycle Gard	5-70	15-150	\$ -



**CIN101 Cycle Gard Constant Pressure Control Valve**

Description	GPM	PSI	List Price
2"F Ductile Iron Cycle Gard	5-70	50 (Adjustable)	\$ -



**CIN101 Cycle Gard Constant Pressure Control Valve**

Description	GPM	PSI	List Price
3"F Ductile Iron Cycle Gard	5-300	60 (Adjustable)	\$ -



The Cycle Gard®, Constant Pressure Pump Control Valve provides "City Like Pressure", which helps reduce rapid pump cycling and maintains a pre-set operating pressure. The Cycle Gard® provides proven pump cycling protection for water well systems, irrigation and booster systems and is designed to stop rapid pump cycling, save electricity, eliminate water hammer while providing a constant pressure regardless of water flow.



**BURY HYDRANT**

Mfg Number.	Bury Depth	List Price
4802LF	2'	\$ -
4803LF	3'	\$ -

- \*3/4" NPT Female Inlet
- \*3/4" Male Hose Thread Outlet
- \*Plunger can be replaced without digging the hydrant up
- \*Polyester Powder Coat Finish



**HOSE BIBS**

Description	List Price
1/2" Hose Bib	\$ -
1/2" Hose Bib (1/4 Turn)	\$ -
3/4" Hose Bib	\$ -
3/4" Hose Bib (1/4 Turn)	\$ -

- \*Certified Lead Free



**AIR VENTS**

Description	List Price
1" Plastic Air Vent	\$ -
2" Aluminum Air Vent	\$ -
3" Aluminum Air Vent	\$ -
4" Aluminum Air Vent	\$ -



3/4" Screened Air Vent	\$ -
------------------------	------



1/2" Vent Pipe	\$ -
----------------	------



**D&K Manufacturing**

Description	List Price
2" x 4" Clearview Coupling	\$ -
2" x 6" Clearview Coupling	\$ -
2-1/2" x 4" Clearview Coupling	\$ -
2-1/2" x 6" Clearview Coupling	\$ -
3" x 4" Clearview Coupling	\$ -
3" x 6" Clearview Coupling	\$ -
4" x 4" Clearview Coupling	\$ -
4" x 6" Clearview Coupling	\$ -
5" x 4" Clearview Coupling	\$ -
5" x 6" Clearview Coupling	\$ -
6" x 4" Clearview Coupling	\$ -
6" x 6" Clearview Coupling	\$ -
8" x 4" Clearview Coupling	\$ -
8" x 6" Clearview Coupling	\$ -



Description	List Price
2" x 4" Sight Check	\$ -
2" x 6" Sight Check	\$ -
2-1/2" x 4" Sight Check	\$ -
2-1/2" x 6" Sight Check	\$ -
3" x 4" Sight Check	\$ -
3" x 6" Sight Check	\$ -
4" x 4" Sight Check	\$ -
4" x 6" Sight Check	\$ -
5" x 4" Sight Check	\$ -
5" x 6" Sight Check	\$ -
6" x 4" Sight Check	\$ -
6" x 6" Sight Check	\$ -
8" x 4" Sight Check	\$ -
8" x 6" Sight Check	\$ -



Description	List Price
2" x 4" Steel Dresser Cplg	\$ -
2" x 6" Steel Dresser Cplg	\$ -
2-1/2" x 4" Steel Dresser Cplg	\$ -
2-1/2" x 6" Steel Dresser Cplg	\$ -
3" x 4" Steel Dresser Cplg	\$ -
3" x 6" Steel Dresser Cplg	\$ -
4" x 4" Steel Dresser Cplg	\$ -
4" x 6" Steel Dresser Cplg	\$ -
5" x 4" Steel Dresser Cplg	\$ -
5" x 6" Steel Dresser Cplg	\$ -
6" x 4" Steel Dresser Cplg	\$ -
6" x 6" Steel Dresser Cplg	\$ -
8" x 4" Steel Dresser Cplg	\$ -



Description	List Price
2" x 4" Clearview Sleeve	\$ -
2" x 6" Clearview Sleeve	\$ -
2 1/2" x 4" Clearview Sleeve	\$ -
2 1/2" x 6" Clearview Sleeve	\$ -
3" x 4" Clearview Sleeve	\$ -
3" x 6" Clearview Sleeve	\$ -
4" x 4" Clearview Sleeve	\$ -
4" x 6" Clearview Sleeve	\$ -
5" x 4" Clearview Sleeve	\$ -
5" x 6" Clearview Sleeve	\$ -
6" x 4" Clearview Sleeve	\$ -
6" x 6" Clearview Sleeve	\$ -
8" x 4" Clearview Sleeve	\$ -



Description	List Price
2" Rubber Gasket	\$ -
2 1/2" Rubber Gasket	\$ -
3" Rubber Gasket	\$ -
4" Rubber Gasket	\$ -
5" Rubber Gasket	\$ -
6" Rubber Gasket	\$ -
8" Rubber Gasket	\$ -



Description	List Price
2" Steel End Ring	\$ -
2 1/2" Steel End Ring	\$ -
3" Steel End Ring	\$ -
4" Steel End Ring	\$ -
5" Steel End Ring	\$ -
6" Steel End Ring	\$ -
8" Steel End Ring	\$ -



## WELL SUPPLIES

<b>Section</b>	<b>Page</b>
Badger Flow Meters	F-1
Pitless Adapters	F-2
Centralizers	F-3
Well Caps	F-4
Well Seals	F-5
Steel Well Plates	F-6
Water Filters	F-7
Lakos Sand Separators	F-8
Cetco Drilling Products	F-9

**BADGER FLOW METERS**

**M5000 MAG Meter**

Size	GPM Flow Range		Length	List Price
	MIN	MAX		
1/2"	0.09	27	6.7"	
3/4"	0.15	49	6.7"	
1"	0.24	77	8.9"	
1-1/4"	0.39	127	8.9"	
1-1/2"	0.4	199	8.9"	Call
2"	0.94	311	8.9"	For
2-1/2"	1.58	525	11"	Current
3"	2.39	796	11"	Pricing
4"	3.74	1244	11"	
5"	5.84	1946	15.8"	
6"	8.4	2799	15.8"	
8"	15	4976	15.8"	
10"	23.4	7775	19.7"	
12"	33.6	11196	19.7"	

- Available in sizes 0.50...24 in. (15...600 mm)
- Battery powered (10 year life)
- ± 0.4% of measured value ± 2 mm/s accuracy independent of fluid viscosity, density and temperature
- Unaffected by most solids contained in fluids
- Pulsed DC magnetic field for zero point stability
- No pressure loss for low operational costs
- Corrosion resistant liners for long life
- Calibrated in state-of-the art facilities
- Integral and remote signal converter availability
- Optional grounding rings or grounding electrode
- Measurement largely independent of flow profile
- Low-power digital microcontroller (16 bit)
- Simple programming procedure
- Digital and infrared outputs
- Automatic zero-point stability
- Non-volatile programming
- NSF listed
- Data logging
- Available with a hard rubber liner or PTFE liner
- Available with 150-lb and 300-lb flanges





**BRONZE PITLESS ADAPTERS**

Model	Discharge Pipe	Drop Pipe	I.D. Casing	Working Load	List Price
1850LF	1"	1"	5" to 8"	800lbs	\$ -
1851LF	1½"	1½"	5" to 8"	2000lbs	\$ -



**STAINLESS STEEL PITLESS ADAPTERS**

Model	Discharge Pipe	Drop Pipe	I.D. Casing	Working Load	List Price
1850SS	1"	1"	5" to 8"	800lbs	\$ -
1851SS	1½"	1½"	5" to 8"	2000lbs	\$ -



**MAASS DICKEN PITLESS ADAPTERS**

Model	Discharge Pipe	Drop Pipe	I.D. Casing	Working Load	List Price
LD-S-10	1"	1"	5" to 12"	2000lbs	\$ -
LD-S-12	1½"	1½"	5" to 12"	2000lbs	\$ -
S-10	1"	1"	5" to 12"	5000lbs	\$ -
S-12	1½"	1½"	5" to 12"	5000lbs	\$ -
S-15	1½"	1½"	5" to 12"	5000lbs	\$ -
S-20	2"	2"	5" to 12"	5000lbs	\$ -



**MAASS MIDWEST WELD-ON PITLESS ADAPTERS**

Model	Discharge Pipe	Drop Pipe	I.D. Casing	Working Load	List Price
J41	1"	1"	4-5"	4000lbs	\$ -
4J1 ¼	1½"	1½"	4-5"	5000lbs	\$ -
4J1 ½	1½"	1½"	4-5"	5000lbs	\$ -
5J2	2"	2"	5"	6000lbs	\$ -
6J1	1"	1"	6-7-8"+	4000lbs	\$ -
6J1 ¼	1½"	1½"	6-7-8"+	5000lbs	\$ -
6J1 ½	1½"	1½"	6-7-8"+	5000lbs	\$ -
6J2	2"	2"	6-7-8"+	6000lbs	\$ -
6J2 ½	2½"	2½"	6-7-8"+	8000lbs	\$ -
8J3	3"	3"	8-10-12"+	10000lbs	\$ -
10J4	4"	4"	10-12-14"+	15000lbs	\$ -



**STEEL PITLESS COLUMNS**

Description	List Price
5" x 5' Blank Steel Column - Threaded on One End	\$ -
6" x 5' Blank Steel Column - Threaded on One End	\$ -



**TORQUE ARRESTOR**

MFG Part Number	Pipe Size	Material	Casing Size	List Price
1350	1"-1¼"	Rubber	4"- 8"	\$ -

*\*Supplied with 2 stainless steel clamps  
\*NSF Approved*



**CABLE PROTECTORS**

MFG Part Number	Pipe Size	Material	Casing Size	List Price
1358	1"-1¼"	Plastic	4"- 8"	\$ -



**CENTERING SPIDERS**

MFG Part Number	Pipe Size	Material	Casing Size	List Price
TAS46-10	1"	Rubber	4"- 6"	\$ -
TAS46-12	1¼"	Rubber	4"- 6"	\$ -
TAS46-15	1½"	Rubber	4"- 6"	\$ -
TAS46-20	2"	Rubber	4"- 6"	\$ -

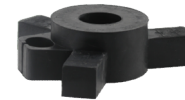

**KWIK-ZIP HD SERIES CENTRALIZERS**

Model	Runner Height	Recommended Pipe		Carton Quantity	List Price
		Runner Height	Diameter		
HD 30	30mm / 1-3/16"	4" & Greater	30	\$ -	
HD 50	50mm / 2"	4" & Greater	30	\$ -	
HD 75	75mm / 3"	4" & Greater	30	\$ -	
HD 100	100mm / 4"	4" & Greater	30	\$ -	



**Sizing Table - HD Series - Vertical**

Nominal Pipe Size (NPS)	OD of Pipe (mm)	OD of Pipe (Inches)	Suggested Number of Segments	Approx Setting Guide Position
	110	4.33	2	0
4	114.30	4.50	2	15
4.5	127.00	5.00	2	30
5	141.30	5.563	2	55
	160	6.30	3	0
6	168.27	6.625	3	5
	180	7.09	3	20
	200	7.87	3	40
8	219.08	8.625	3	65
	250	9.84	4	25
10	273.05	10.75	4	45
12	323.85	12.75	4	80
14	355.60	14.00	5	50
16	406.40	16.00	6	35
18	457.20	18.00	6	65
20	508.00	20.00	7	55
24	609.60	24.00	8	65
	650	25.59	9	50
	710	27.95	9	70
	800	31.50	10	75
	900	35.43	12	60
	1000	39.37	13	65
	1100	43.30	14	70
	1200	47.24	17	45

Please refer to the relevant product series installation guide for additional information

**WELL CAPS**

**Aluminum Well Caps**

Model	Description	O.D. Casing	Conduit Fitting	List Price
CC-5	5" Aluminum Well Caps	5-9/16"	1"	\$ -
CC-6	6" Aluminum Well Caps	6-5/8"	1"	\$ -
CC-8	8" Aluminum Well Caps	8-5/8"	1"	\$ -

- Can be personalized, 50 piece minimum
- Cast aluminum alloy 319 - will not crack or warp
- Fitted for 1" conduit
- Three square head stainless steel cup point set screws
- Designed for 1/64" clearance fit to prevent foreign matter intrusion
- Model CC-ID cap 1-1/4" conduit as standard



**Water Tight Aluminum Well Caps**

Model	Description	O.D. Casing	Conduit Fitting	List Price
WTCC-4	4" Water Tight Aluminum Well Caps	4-1/2"	1"	\$ -
WTCC-5	5" Water Tight Aluminum Well Caps	5-9/16"	1"	\$ -
WTCC-6	6" Water Tight Aluminum Well Caps	6-5/8"	1 1/4"	\$ -
WTCC-8	8" Water Tight Aluminum Well Caps	8-5/8"	1 1/4"	\$ -

- WTCC caps Water Systems Council - PAS-2 listed
- Cast aluminum with stainless steel bolts
- WTCC models are vented to meet state codes
- Can be personalized, 50 piece minimum
- Five bolt pulldown for sure seal and tamper resistance
- Heavy Buna-N Seal prevents foreign matter intrusion
- Buna-N rubber seal is internal to cap assembly and is not exposed to outside environment



**Baker Premium Water Tight Cast Iron Well Caps**

Model	Description	O.D. Casing	Conduit Fitting	List Price
4W	Cast Iron Premium Water Tight Well Cap	4-1/2"	1 1/2"	\$ -
5W	Cast Iron Premium Water Tight Well Cap	5-9/16"	1 1/2"	\$ -
6W	Cast Iron Premium Water Tight Well Cap	6-5/8"	1 1/2"	\$ -
6.6W	Cast Iron Premium Water Tight Well Cap	7"	1 1/2"	\$ -
7W	Cast Iron Premium Water Tight Well Cap	7-5/8"	1 1/2"	\$ -
8W	Cast Iron Premium Water Tight Well Cap	8-5/8"	1 1/2"	\$ -
10W	Cast Iron Premium Water Tight Well Cap	10-3/4"	3"	\$ -
12W	Cast Iron Premium Water Tight Well Cap	12-3/4"	3"	\$ -

- The top of the cap can be removed without effecting the seal, conduit or wiring.
- The Premium Watertight Cap is made of high quality grey cast iron.
- Painted green and oven dried to produce a durable high quality finish.
- All our high quality hardware is plated.
- Conforms to Water System Council PAS-97 (04) Standards.
- Premium Watertight Cap can be used as a vacuum seal when conduit is plugged.



**ABS Well Seals**

Well Size I.D.	Drop Pipe Size	Cable Hole Tapping	Vent Tapping	List Price
5"	1"	¾"	½"	\$ -
5"	1¼"	¾"	½"	\$ -
5"	1½"	¾"	½"	\$ -
5"	2"	¾"	½"	\$ -
6"	1"	¾"	½"	\$ -
6"	1¼"	¾"	½"	\$ -
6"	1½"	¾"	½"	\$ -
6"	2"	¾"	½"	\$ -



- \*Hi Impact ABS Material
- \*Zinc plated steel bolts
- \*Extra thick molded rubber packer

**Steel Well Seal - Single Drop Pipe**

Well Size I.D.	Drop Pipe Size	Cable Hole Tapping	Vent Tapping	List Price
5"	1"	1"	½"	\$ -
5"	1¼"	1"	½"	\$ -
5"	1½"	¾"	½"	\$ -
5"	2"	¾"	½"	\$ -
6"	1"	1"	½"	\$ -
6"	1¼"	1"	½"	\$ -
6"	1½"	1"	½"	\$ -
6"	2"	¾"	½"	\$ -
8"	1"	1"	½"	\$ -
8"	1¼"	1"	½"	\$ -
8"	1½"	1"	½"	\$ -
8"	2"	1"	½"	\$ -
8"	2½"	1"	½"	\$ -
8"	3"	1"	½"	\$ -
8"	4"	1"	½"	\$ -



- \*A36 hot roll steel
- \*Galvanized steel bolts
- \*¾" molded rubber, 35 durometer
- \*Powder coated polyester finish

**STEEL WELL PLATES**

Size	Thickness	Pipe Size	Shape	List Price
24"	3/8"	2"	Square	\$ -
24"	3/8"	2-1/2"	Square	\$ -
24"	3/8"	3"	Square	\$ -
24"	3/8"	4"	Square	\$ -
24"	1/2"	2"	Square	\$ -
24"	1/2"	2-1/2"	Square	\$ -
24"	1/2"	3"	Square	\$ -
24"	1/2"	4"	Square	\$ -
24"	1/2"	5"	Square	\$ -
24"	1/2"	6"	Square	\$ -

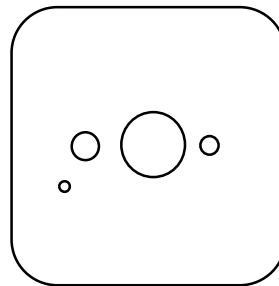

SIZE	Thickness	Pipe Size	Shape	List Price
16"	3/8"	2"	Round	\$ -
16"	3/8"	2-1/2"	Round	\$ -
16"	3/8"	3"	Round	\$ -
16"	3/8"	4"	Round	\$ -
16"	1/2"	2"	Round	\$ -
16"	1/2"	2-1/2"	Round	\$ -
16"	1/2"	3"	Round	\$ -
16"	1/2"	4"	Round	\$ -

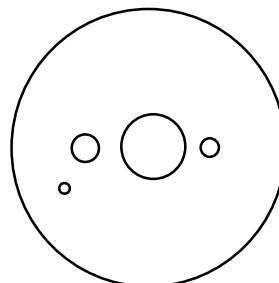

### Filtration

#### Filter Housings

Inlet/ Outlet	Sump Color	Max Pressure Rating	Dimensions Width x Length	List Price
3/4"	Clear	125 PSI	4.61" x 11.65"	\$ -
1"	Blue	125 PSI	7.38" x 13.51"	\$ -
1-1/2"	Blue	125 PSI	7.38" x 13.51"	\$ -



#### Sediment Filter Cartridges

Filter Type	Material	Micron	Dimensions Width x Length	List Price
Wound	Polypropylene	5	2.50" x 10"	\$ -
Wound	Polypropylene	10	2.50" x 10"	\$ -
Wound	Polypropylene	25	2.50" x 10"	\$ -
Pleated	Polyester	20	4.50" x 10"	\$ -
Pleated	Polyester	50	4.50" x 10"	\$ -



#### Taste & Odor Filter Cartridges

Filter Type	Material	Micron	Dimensions Width x Length	List Price
Taste & Odor	GAC	5	2.50" x 10"	\$ -
Taste & Odor	GAC	5	4.50" x 10"	\$ -



#### Twist II Clean Filters

Model	Max Flow Rate	Inlet/Outlet Size	Screen Mesh Size	List Price
T2C-100	39 GPM	1" Male NPT	100 Mesh / 150 Micron	\$ -
T2C-150	78 GPM	1 1/2" Male NPT	100 Mesh / 150 Micron	\$ -



#### Twist II Clean Repair Parts

Description	List Price
1" Twist II Clean Filter Element Kit	\$ -
1" Twist II Clean Repair Kit - O-Rings / Pin / Red Pull Tab	\$ -
1 1/2" Twist II Clean Filter Element Kit	\$ -
1 1/2" Twist II Clean Repair Kit - O-Rings / Red Pull Tab	\$ -



**LAKOS SAND SEPARATORS**

**Sandmaster Plus (SMP) Series**

Model	Flow Range U.S. gpm	Inlet/Outlet Size Male, N.P.T	Dry Weight Lbs.	List Price
SMP-05	5-10	1/2"	7	\$ -
SMP-10	10-20	3/4"	8	\$ -
SMP-20	20-32	1"	13	\$ -
SMP-30	30-48	1-1/4"	13	\$ -
SMP-45	45-70	1-1/2"	13	\$ -

\*Purge pipe size for all models is 3/4"

\*100psi pressure rating



**ILB Series**

Model	Flow Range U.S. gpm	Inlet/Outlet Size Male, N.P.T	Dry Weight Lbs.	List Price
ILB-0050	4-10	1/2"	14	\$ -
ILB-0075	10-20	3/4"	15	\$ -
ILB-0100	19-32	1"	27	\$ -
ILB-0125	28-48	1-1/4"	27	\$ -
ILB-0150	45-70	1-1/2"	27	\$ -
ILB-0200	65-108	2"	52	\$ -
ILB-0250	98-155	2-1/2"	60	\$ -
ILB-0300	148-290	3"	101	\$ -

\*Purge pipe size for all models is 3/4"

\*150psi pressure rating



**LAKOS ACCESSORIES**

Model	Description	List Price
MBCK-0510	Mounting Bracket Clamp Kit For SMP-05 thru SMP-10	\$ -
MBCK-2045	Mounting Bracket Clamp Kit For SMP-20 thru SMP-45	\$ -
MBCK-015	Mounting Bracket Clamp Kit For ILB-0050	\$ -
MBCK-022	Mounting Bracket Clamp Kit For ILB-0075	\$ -
MBCK-033	Mounting Bracket Clamp Kit For ILB-0100 thru ILB-0150	\$ -
MBCK-052	Mounting Bracket Clamp Kit For ILB-0200 thru ILB-0250	\$ -
MBCK-062	Mounting Bracket Clamp Kit For ILB-0300	\$ -
AP-75-MBV	3/4" AccuPurge Automatic Valve (110 or 220 VAC)	\$ -



**Cetco Drilling Products**

PREMIUM GEL® is a 200 mesh, 90 bbl yield sodium bentonite for freshwater drilling, slurry walls, and tunnel boring. PREMIUM GEL complies with API 13A Section 9, Specifications for Drilling Fluid Materials. NSF/ANSI Standard 60 Certified.



SUPER GEL-X® is an easy mixing, high viscosity 200 bbl yield freshwater drilling fluid produced from the highest grade Wyoming sodium bentonite. May be used for all types of freshwater mud rotary drilling. NSF/ANSI Standard 60 Certified.



ACCU-VIS® (PHPA, 50% Active) is a liquid copolymer designed for fast field mixing, viscosity building, and clay/shale stabilization in aqueous drilling fluids. NSF/ANSI Standard 60 Certified.



SUPER THIN™ is a highly concentrated additive engineered to reduce drilling fluid viscosity. It offers immediate thinning action, reduces gel strength, and is more cost-effective than traditional thinners. NSF/ANSI Standard 60 Certified.



INSTA-VIS™ LOW VISCOSITY is an easy-mixing, watersoluble, polymer used in horizontal and vertical drilling applications. Ideal for use in recycling systems. NSF/ANSI Standard 60 Certified.



MAGMA FIBER is a specially formulated, extrusion spun mineral fiber loss circulation material. This coarse, long, and flexible fiber will give increased circulation by bridging and plugging off voids, fractures, and all types of permeable formations.



REL-PAC® (PAC, Dry) is a non-fermenting granular polymer designed for building a low solids drilling fluid with increased borehole stability. REL-PAC is a highly dispersible polymer, that improves drilling fluid efficiency.



VERSAFOAM® PLUS is an ultra high-yielding, biodegradable, liquid foaming agent for use in fresh and saltwater air rotary drilling. Dry air rotary drilling or mixed with water for foam drilling. NSF/ANSI Standard 60 Certified.



C/S GRANULAR and CETCO CRUMBLES are granular bentonite products composed of polymer-free, dried bentonite in various mesh sizes. CETCO CRUMBLES are coarser in size than C/S GRANULAR. C/S GRANULAR and CETCO CRUMBLES are certified to NSF/ANSI Standard 60.



CETCO COATED TABLETS are coated using an aqueous carrier to apply the coating. The coating allows the tablets to reach a discrete depth within the waterwell, piezometer, monitoring well, or annular space. These untreated organic tablets are compressed into 1/4" (0.64 cm) and 3/8" (0.95 cm) sizes. CETCO COATED TABLETS are certified to NSF/ANSI Standard 60.



CETCO COARSE CHIPS are natural sodium bentonite screened to 3/8 inch (0.95 cm) to 3/4 inch (1.90 cm) in size. PUREGOLD MEDIUM CHIPS are natural sodium bentonite screened to 1/4 inch (0.64 cm) to 3/8 inch (0.95 cm) in size. CETCO COARSE CHIPS and PUREGOLD MEDIUM CHIPS are certified to NSF/ANSI Standard 60.



CETCO GROUT is a 20% solids, polymer-free, single-component, easy-to use sodium bentonite grout available in powdered form. CETCO GROUT allows placement in a low viscosity state. CETCO GROUT is certified to NSF/ANSI Standard 60.





**Cetco Drilling Products**

**Drilling Fluids**

Description	Function	Packaging	Pallet Qty	List Price
Hydraul-EZ	Drilling Fluid - HDD	50 lb Bags	48	\$ -
Premium Gel	Drilling Fluid - API 13A, Section 9	50 lb Bags	48	\$ -
Super Gel-X	Drilling Fluid - High Yield	50 lb Bags	48	\$ -

**Grouts & Sealants**

Description	Function	Packaging	Pallet Qty	List Price
Cetco Crumbles	Sealant - 8/20 Mesh	50 lb Bags	48	\$ -
Cetco Grout	Grout - 20% Solids	50 lb Bags	48	\$ -
Cetco Tablets	Sealant - 1/2", 1/4", 3/8"	50 lb Pails	36	\$ -
Puregold Medium Chips	Sealant - 1/4" - 3/8"	50 lb Bags	48	\$ -

**Loss Circulation Material (LCM)**

Description	Function	Packaging	Pallet Qty	List Price
Magma Fiber	LCM - Acid Soluble	25 lb Bags	48	\$ -

**Polymers & Additives**

Description	Function	Packaging	Pallet Qty	List Price
Accu-Vis	Viscosifier / Clay Inhibitor	44 lb Pails	32	\$ -
Insta-Vis Low Viscosity	Low Viscosity / Clay Inhibitor	36 lb Pails	36	\$ -
Rel-Pac	Fluid Loss Control	25 lb Pails	36	\$ -
Rel-Pac	Fluid Loss Control	50 lb Bags	40	\$ -
Super Thin	Dispersant	45 lb Pails	32	\$ -
Versafoam Plus	Drilling Foam	43 lb Pails	32	\$ -



## **Technical Data**



**FRICITION LOSS IN WATER PIPES PER 100 FEET OF NEW WROUGHT IRON OR STEEL PIPE**

Pipe Size	Friction Velocity Loss		Friction Velocity Loss		Friction Velocity Loss		Friction Velocity Loss		Friction Velocity Loss		Friction Velocity Loss	
	3/4"		1"		1-1/4"		1-1/2"		2"		2-1/2"	
G.P.M.	Velocity - Velocity Feet Per Second		Friction - Friction Loss in Feet		Friction - Friction Loss in Feet		Friction - Friction Loss in Feet		Friction - Friction Loss in Feet		Friction - Friction Loss in Feet	
3	1.81	2.50	1.11	0.77								
5	3.01	6.32	1.86	1.93								
7	4.21	11.80	2.60	3.56								
10	6.02	23.00	3.71	7.86	2.15	1.77						
16	9.63	56.03	5.44	16.50	3.43	4.20	2.52	1.96				
20			7.42	25.10	4.29	6.34	3.15	2.94	1.91	0.87		
26	3"		9.65	41.60	5.58	10.37	4.10	4.81	2.49	1.39		
30			11.10	54.60	6.44	13.60	4.73	6.26	2.87	1.82	2.01	0.75
40					8.58	23.50	6.30	10.79	3.82	3.10	2.68	1.28
50	2.17	0.60	4"				7.88	16.40	4.78	4.67	3.35	1.94
60	2.60	0.90			5"		9.46	23.20	5.74	6.59	4.02	2.72
80	3.47	1.57					12.60	40.50	7.65	11.40	5.36	4.66
100	4.34	2.39	2.52	0.62					9.56	17.40	6.70	7.11
120	5.21	3.37	3.02	0.88			5"		11.50	24.70	8.04	10.00
140	6.08	4.51	3.53	1.66	2.25	0.38					10.05	15.40
200	8.68	8.90	5.04	2.27	3.21	0.74			8"		13.40	26.70
240	10.04	12.06	6.05	3.21	3.85	1.03	2.66	0.41				
300	13.00	19.20	7.56	4.89	4.81	1.58	3.33	0.64	1.92	0.16		10"
340	14.08	24.08	8.57	6.19	5.45	2.00	3.78	0.81	2.18	0.20		
400	17.40	33.90	10.10	8.47	6.41	2.72	4.44	1.09	2.57	0.28		
440			11.01	10.02	7.06	3.26	4.89	1.31	2.81	0.33		
500	12"		12.60	13.00	8.02	4.16	5.55	1.66	3.21	0.42	2.03	0.14
600			15.10	18.60	9.62	5.88	6.66	2.34	3.85	0.60	2.44	0.19
700					11.20	7.93	7.77	3.13	4.49	0.80	2.85	0.26
800					12.80	10.22	8.88	4.03	5.13	1.02	3.25	0.33
850							9.44	4.53	5.45	1.15	3.46	0.37
900	2.58	0.17					9.99	5.05	5.77	1.27	3.66	0.41
950	2.72	0.19					10.50	5.60	6.09	1.41	3.87	0.46
1000	2.87	0.21					11.10	6.17	6.41	1.56	4.07	0.50
1100	3.15	0.25							7.05	1.87	4.48	0.60
1200	3.44	0.30							7.70	2.20	4.88	0.70
1300	3.73	0.34							8.34	2.56	5.29	0.82
1500	4.30	0.45							9.62	3.37	6.10	1.07
1700	4.87	0.57							10.90	4.29	6.92	1.36
2000	5.73	0.78							12.80	5.86	8.14	1.86
2200	6.31	0.93									8.95	2.23
2400	6.88	1.09									9.76	2.64
2800	8.03	1.47									11.40	3.56
3000	8.60	1.68									12.20	4.06

- 1) Table shows loss in new pipe only. Allowance must be made for valves, fittings, etc., & for deterioration. If other than new, multiply Friction Loss Values by 1.50
- 2) When capacity is in gpm divide by 80 to determine equivalent gpm.
- 3) To find loss in riser pipe of any specific length divide riser pipe length by 100, multiply the results with the friction loss figure in the Table.
- 4) Try to always use a pipe size that gives AT LEAST 4.0 velocity feet per second.

## FRICTION LOSSES IN ALUMINUM PIPE

LOSS OF HEAD IN FEET PER 100 FEET OF ALUMINUM PIPE

GALLONS PER MINUTE	PIPE SIZE						
	2"	3"	4"	5"	6"	7"	8"
20	1.27	0.15	0.04				
30	2.58	0.38	0.08				
40	4.49	0.56	0.13	0.04			
50	6.85	0.85	0.20	0.07	0.03		
60	9.67	1.21	0.28	0.09	0.04		
70	12.95	1.67	0.38	0.12	0.05		
80	16.70	2.06	0.49	0.19	0.06	0.03	
90	20.80	2.58	0.60	0.20	0.08	0.04	
100	25.40	3.18	0.74	0.24	0.10	0.05	0.03
120		4.51	1.06	0.34	0.14	0.07	0.04
140		6.00	1.41	0.46	0.19	0.07	0.05
160		7.76	1.82	0.59	0.24	0.11	0.06
180		9.67	2.27	0.73	0.30	0.14	0.07
200		11.83	2.78	0.89	0.36	0.17	0.09
220		14.12	3.31	1.07	0.44	0.20	0.11
240		16.72	3.91	1.27	0.52	0.24	0.13
260		19.42	4.56	1.47	0.60	0.28	0.15
280		22.40	5.26	1.71	0.69	0.33	0.17
300		25.45	5.98	1.95	0.79	0.37	0.19
350			8.03	2.59	1.05	0.50	0.26
400			10.36	3.33	1.35	0.64	0.33
450			12.90	4.15	1.69	0.80	0.41
500			15.73	5.07	2.06	0.97	0.50
550				6.16	2.50	1.18	0.62
600				7.24	2.94	1.38	0.72
650				8.42	3.41	1.62	0.84
700				9.98	3.92	1.86	0.97
750				11.05	4.46	2.11	1.10
800				12.48	5.03	2.38	1.24

**GALLONS PER MINUTE**

Horizontal Distance X	2" Pipe	2-1/2" Pipe	3" Pipe	4" Pipe	5" Pipe
12"	42	60	93	159	250
14"	49	70	108	186	292
16"	56	80	123	212	334
18"	63	90	139	239	376
20"	70	100	154	266	417
22"	77	110	169	292	459
24"	84	120	185	318	501
26"	91	130	200	345	543
28"	98	140	216	372	585
30"	105	150	231	398	627

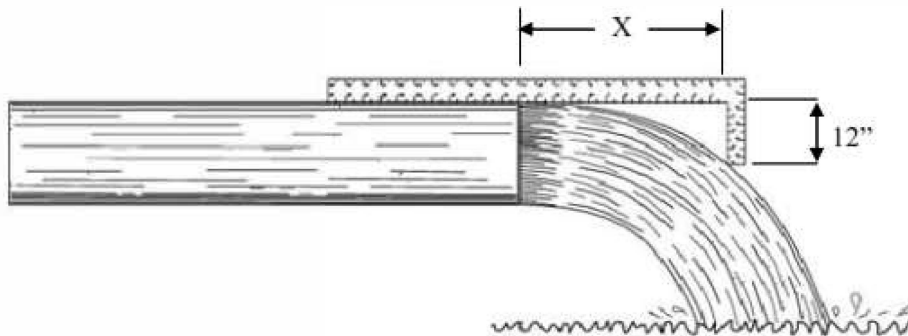

Open System - Three Phase

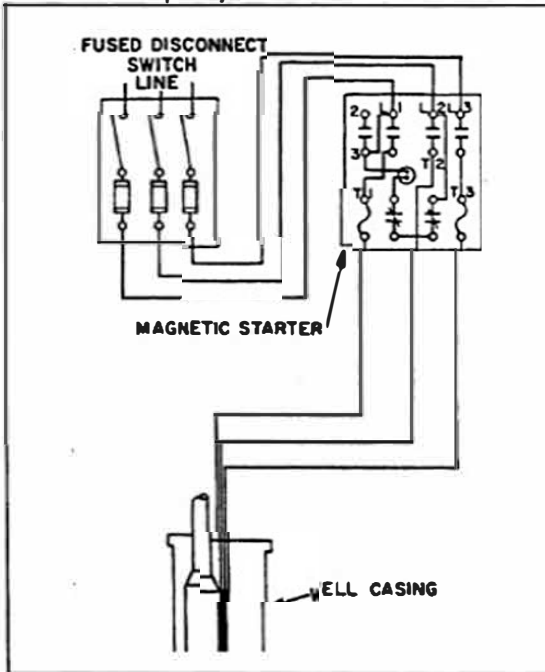

Open System - Single Phase  
1/4 Horsepower - 5 Horsepower

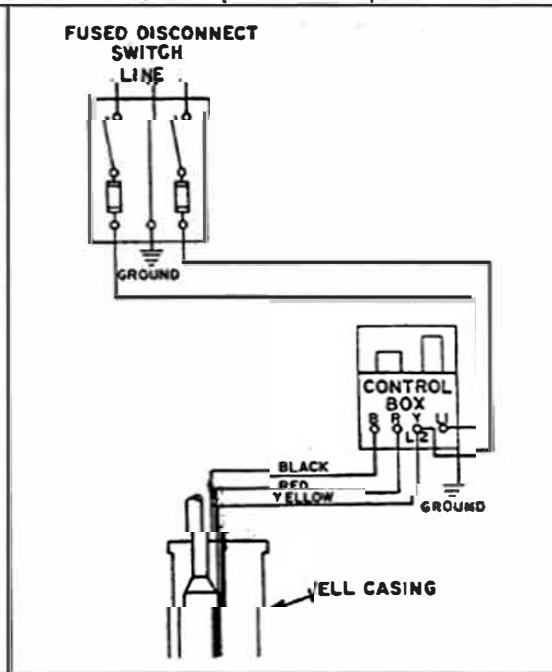

Three Phase - With Pressure Switch

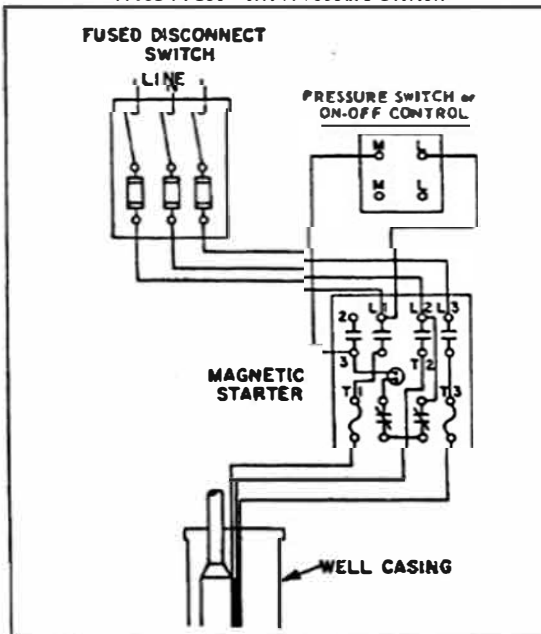

Single Phase - With Pressure Switch, Magnetic Starter  
Recommended Above 3 Horsepower

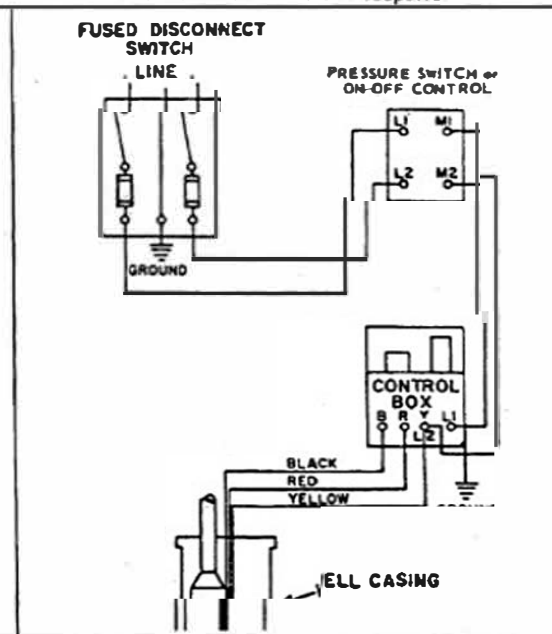

Three Phase With Pressure Switch and Liquid Level Control

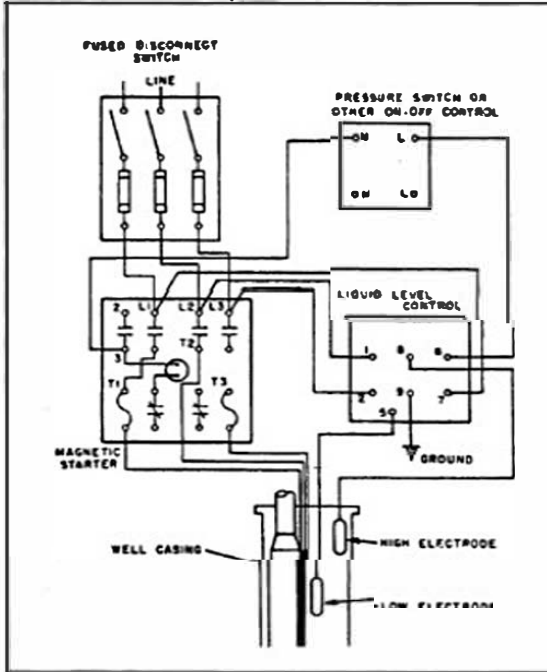

Single Phase With Pressure Switch and Liquid Level Control

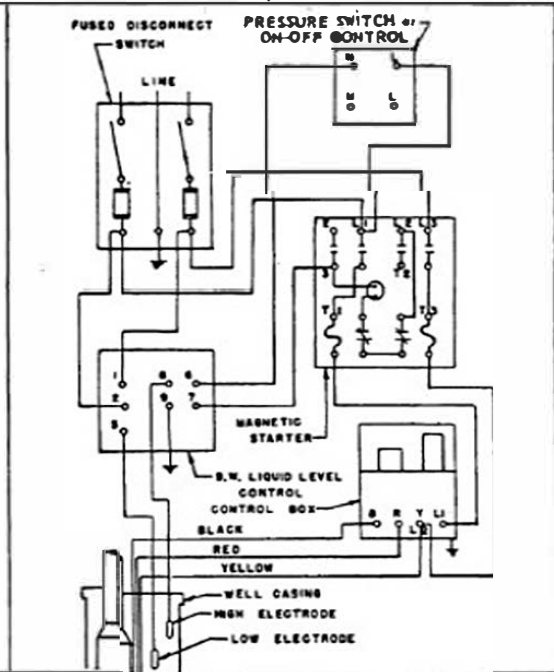

The sketches below show method of attaching lightning arresters to the submersible motor power line.

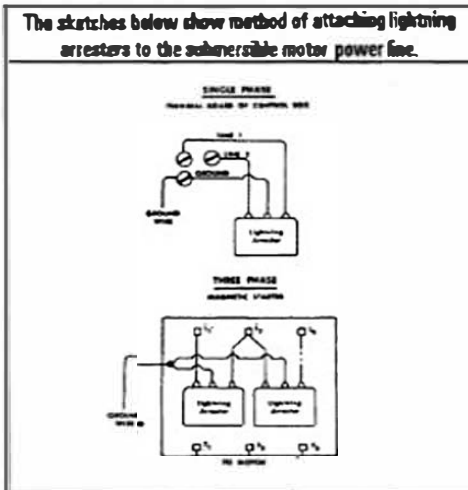

Ground All systems to metal well casing, metal drop pipe, metal ground rod or grounded water pipe.

Consult your local electrical code for wire size.

### PRESSURE SYSTEM INSTALLATION

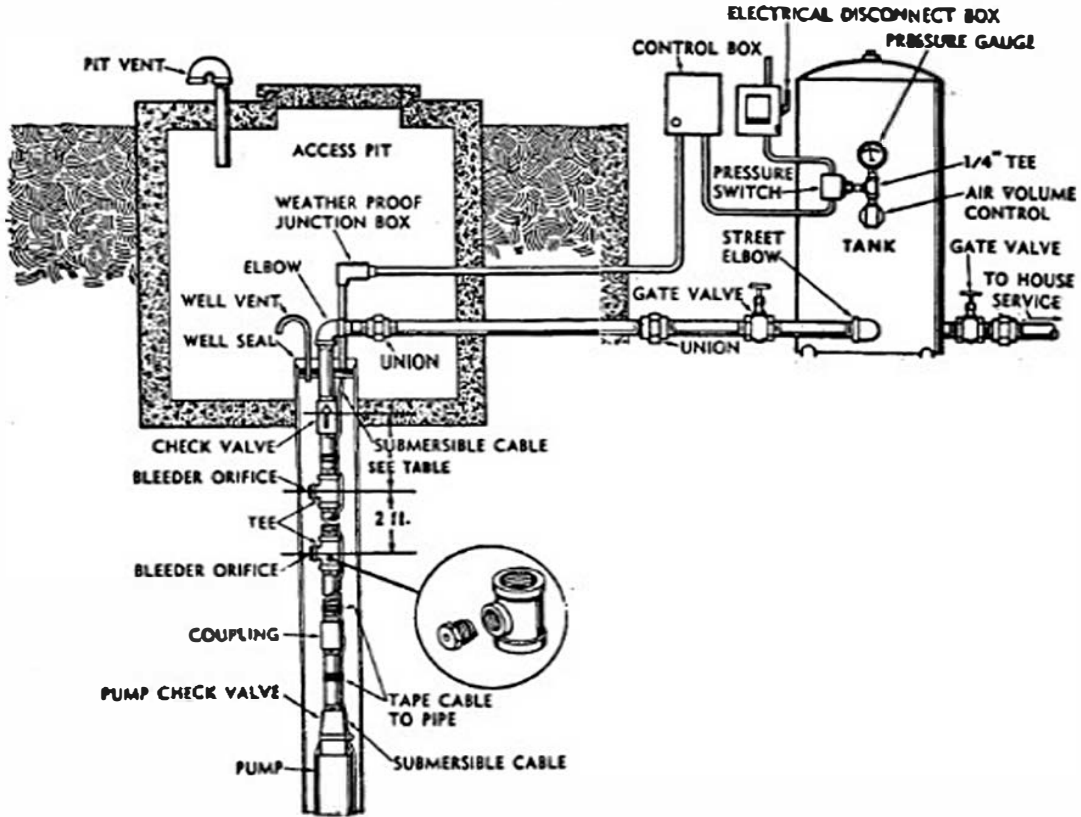

### FOR YOUR RECORD

Pump Model No. \_\_\_\_\_

Pump Serial No. \_\_\_\_\_

Motor Horsepower	Phase	Volts

Date of Installation:    Month    Day    Year

Well Depth:            Feet            Casing Size: \_\_\_\_\_

Drop Pipe Size:        Inches        Pipe Set At            Feet

**NOTE: Refer to your State Water Well code for installation regulations within your state.**



### USEFUL INFORMATION

VOLUME		LENGTH	
	231 cu. in.	1 Inch	2.54 centimeters
	0.113 cu. ft.		
	3.78 litres	1 Meter	3.28 feet
1 U.S. Gallon	.00378 cu. meters		39.37 inches
	0.833 imp. gal.	1 Rod	16.5 feet
	.0238 42-gal. barrel		
1 Imperial Gallon	1.2 U.S. gal.	1 Mile	5280 ft. (1.61 Kilometers)
1 Cubic Foot	7.48 U.S. gal.		
	0.0283 cu. meter		
1 Litre	0.2642 U.S. gal.		
1 Cubic Meter	35.314 cu. ft.		
	264.2 U.S. gal.		
1 Acre Foot	43,560 cu. ft.		
1 Acre Inch	3,630 cu. ft.		
	27,100 U.S. gal.		

**HORSEPOWER**  
 1 H.P. Equals...  
 .746 kilowatts or 746 watts  
 33,000 ft. lbs. per minute  
 550 ft. lbs. per second

**WATER HORSEPOWER**  
 $\frac{\text{GPM} \times 8.33 \times \text{Head}}{33,000} = \frac{\text{GPM} \times \text{Head}}{3960}$

**LABORATORY BHP**  
 $\frac{\text{Head} \times \text{GPM} \times \text{Sp. Gr.}}{3960 \times \text{Eff.}}$   
 GPM - Gallons per Minute  
 Head - Laboratory head (inc. Column Loss)  
 Eff. - Pump Only Efficiency

**MOTOR INPUT HP**  
 $\frac{\text{Laboratory BHP}}{\text{Motor Eff.}}$   
 Total BHP from above  
 Motor Eff. from manufacturer

**UNIT EFFICIENCY**  
 $\frac{\text{Water Horsepower}}{\text{Motor Input Horsepower}}$

CAPACITY	
1 Cubic Foot Per Second (2d foot) (c.f.s.)	449 GPM
1 Acre Foot Per Day	227 GPM
1 Acre Inch Per Hour	454 GPM
1 cubic Meter Per Minute	264.2 GPM
1,000,000 Gallons Per Day	595 GPM

HEAD	
1 Pound Per Square Inch (p.s.i.)	2.31 ft. head of water 2.04 in. mercury 8.07 kg. per sq. cm
1 Foot of Water	0.433 lb. per sq. in. .088 in. mercury
1 Inch of Mercury (or vacuum)	1.132 ft. of water
1 Kilogram Per Square Cm.	14.22 lb. per sq. in.
1 Atmosphere (at sea level)	14.7 lb. per sq. in. 34.0 ft. of water 10.35 meters of water
1 Meter of Water	3.28 feet of water

### Electric Power

AC - Alternating current power  
 DC - Direct current  
 E - Volts - Electrical Pressure (similar to head)  
 I - Amperes - electrical current (similar to rate of flow)  
 W - Watts - Electrical power (similar to head capacity)  
 KW - Kilowatts - 1000 watts  
 Apparent power - volts x amperes = voltamperes  
 Apparent Power - EI  
 Useful Power W - P.F.  
 Power factor - ratio of useful power to apparent power  
 $\frac{W}{EI}$   
 Power factor - PF - EI  
 KW Hr. - Kilowatt hour  
 Single phase power W - E x I x PF  
 Three Phase Power W - 1.73 x I x PF  
 Where E - Average voltage between phases  
 I - Average current in each phase

### To FIND CAPACITY OF A TANK OR A CISTERN:

Diameter of Tank In Feet Squared x .7854 x Height of Tank In Feet x 7.48 = Capacity in U.S. Gallon

### WIRE - TO - WATER EFFICIENCY SUBMERSIBLE PUMPS

A 75 HP, 460/3/60 Submersible Pump Model SSP9L-3 has been chosen for duty providing 500 GPM at a total head of 480 ft. The installation utilizes 390 feet of #4-3 individual copper submersible cable, a 75 HP Franklin 8" 460/3/60 Submersible Motor, a 3 stage SSP9L Pump with impellers trimmed for the duty condition, and 375 feet of 6" Schedule 40 Column Pipe.

In order to calculate the wire-to-water efficiency (also known as overall or plant efficiency), the following data must be known.

- |                      |                           |
|----------------------|---------------------------|
| 1. Pump Efficiency   | 5. Field Head             |
| 2. Motor Efficiency  | 6. Total Head             |
| 3. Cable Power Loss  | 7. Field Water Horsepower |
| 4. Motor Thrust Loss | 8. Motor Input Horsepower |

From the Pump Performance Curve, the pump efficiency at the duty point of 500 GPM is 83.5% for a 3 stage unit. From the Franklin Motor Performance Curves, the full load motor efficiency is 85.0%, and the full load motor current is 97.0 amps. The cable power loss in horsepower per 100 feet of #4-3 cable carrying 97 amps at 460 volts is 1.20 horsepower, as shown in the Submersible Cable Horsepower Loss Chart. The Cable Power Loss for the 390 feet of cable in this application will be 1.20 x 3.90, or 4.68 HP.

Motor Thrust Loss may be calculated by multiplying the thrust factor of the SSP9L pump by the total head to obtain the total thrust on the motor thrust bearing, or 4.5 x 480 feet = 2160 lbs. From the Franklin Motor Performance Curve, the additional input in watts due to 2160 lbs. thrust is 200 watts, or 0.27 HP.

Field Head may be found by subtracting the total friction losses from the Total Head. For the application, the column friction loss from the Column Pipe Friction Loss Chart is 1.66 feet per 100 feet of pipe, so 1.66 x 3.75 = 6.23 feet of column loss. From the Submersible Surface Plate Friction Loss Chart, the friction loss in a 6" surface elbow is 0.19 feet. From the Check Valve Friction Loss Chart, the loss in a 6" Vertical Check Valve is 2.5 feet at 500 GPM. The total friction loss in this application is then 6.23 feet plus 0.19 feet plus 2.5 feet, or 8.92 feet. The Field Head is 480 feet - 8.92 feet or 471 feet.

We now have all the data required to calculate the wire-to-water efficiency.

$$\begin{aligned}
 \text{Field Water HP} &= (\text{GPM} \times \text{Field Head}) / 3960 \\
 &= (500 \times 471) / 3960 \\
 &= 59.47 \text{ HP}
 \end{aligned}$$

$$\begin{aligned}
 \text{Laboratory HP} &= (\text{GPM} \times \text{Total Head}) / (3960 \times \text{Pump Efficiency}) \\
 &= (500 \times 480) / (3960 \times 0.835) \\
 &= 72.58 \text{ HP}
 \end{aligned}$$

**WIRE - TO - WATER EFFICIENCY  
SUBMERSIBLE PUMPS**

$$\begin{aligned}
 \text{Electrical Input HP to Motor in Well} &= (\text{Laboratory HP} + \text{Thrust Loss}) / \text{Motor Efficiency} \\
 &= (72.58 \text{ HP} + 0.27 \text{ HP}) / 0.85 \\
 &= 85.70 \text{ HP}
 \end{aligned}$$

$$\begin{aligned}
 \text{Electrical Input HP to Motor at the Surface} &= (\text{Lab HP} + \text{Thrust Loss}) / \text{Motor Efficiency} + \text{Cable Loss} \\
 &= (72.58 \text{ HP} + 0.27 \text{ HP}) / 0.85 + 4.68 \text{ HP} \\
 &= 90.39 \text{ HP}
 \end{aligned}$$

$$\begin{aligned}
 \text{Wire-to-Water Efficiency} &= \text{Field Water HP} / \text{Motor Input HP at the Surface} \\
 &= 59.47 \text{ HP} / 90.39 \text{ HP} \\
 &= 65.79 \%
 \end{aligned}$$

Once the Wire-to-Water Efficiency has been calculated KW hours per 1000 gallons pumped can be figured by the formula:

$$\begin{aligned}
 \text{KW hours per 1000 gallons pumped} &= (\text{Field Head} \times 0.00314) / \text{Wire-to-Water Efficiency} \\
 &= (471 \times 0.00314) / 0.6579 \\
 &= 2.248 \text{ KW hours per 1000 gallons pumped}
 \end{aligned}$$

Total cost per 1000 gallons pumped may be calculated by multiplying the cost per KW hour (from your Utility or Power Company) by the above number.

SUBMERSIBLE CABLE  
HORSEPOWER LOSS CHART

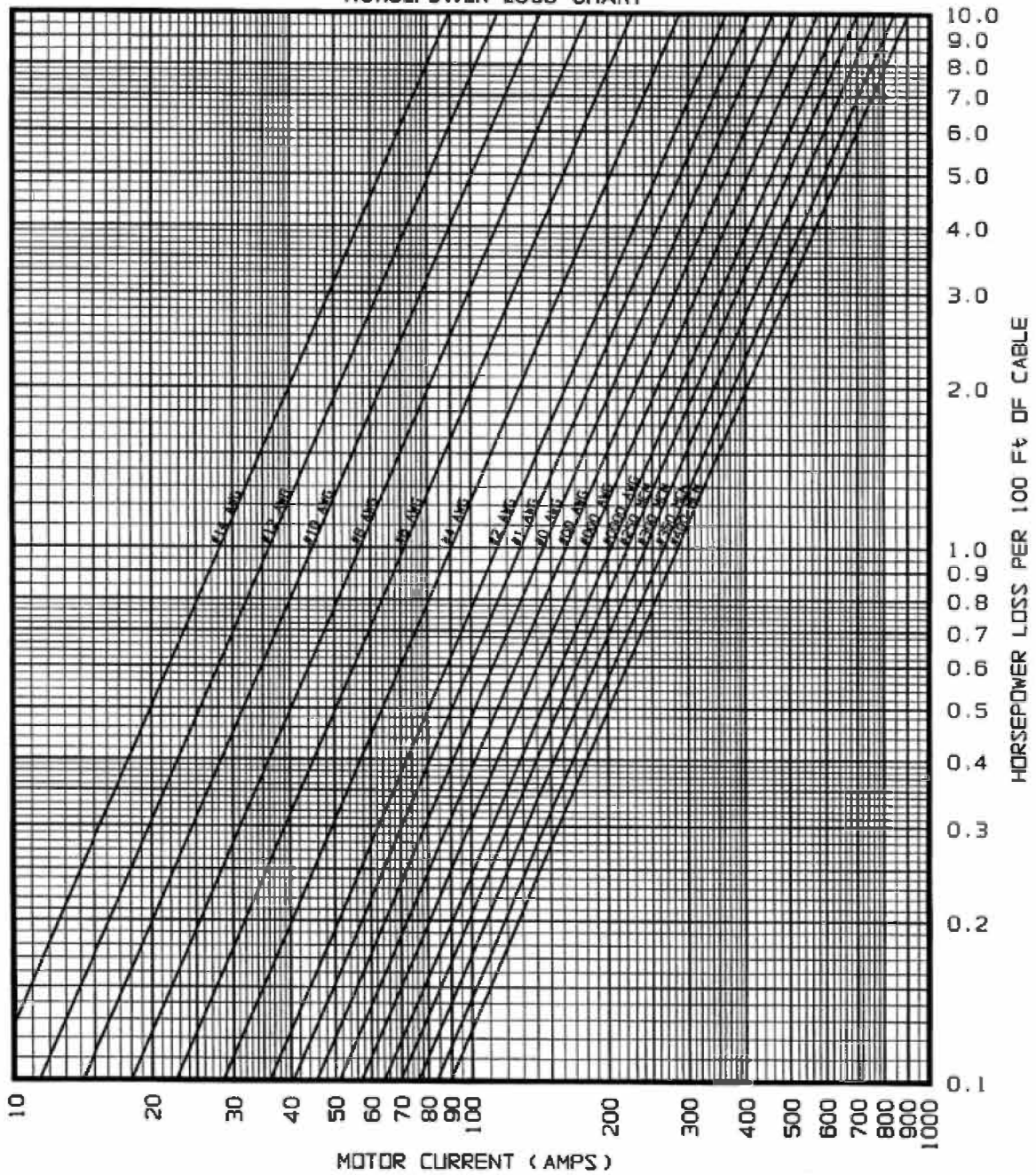

SUBMERSIBLE COLUMN PIPE  
VELOCITY CHART

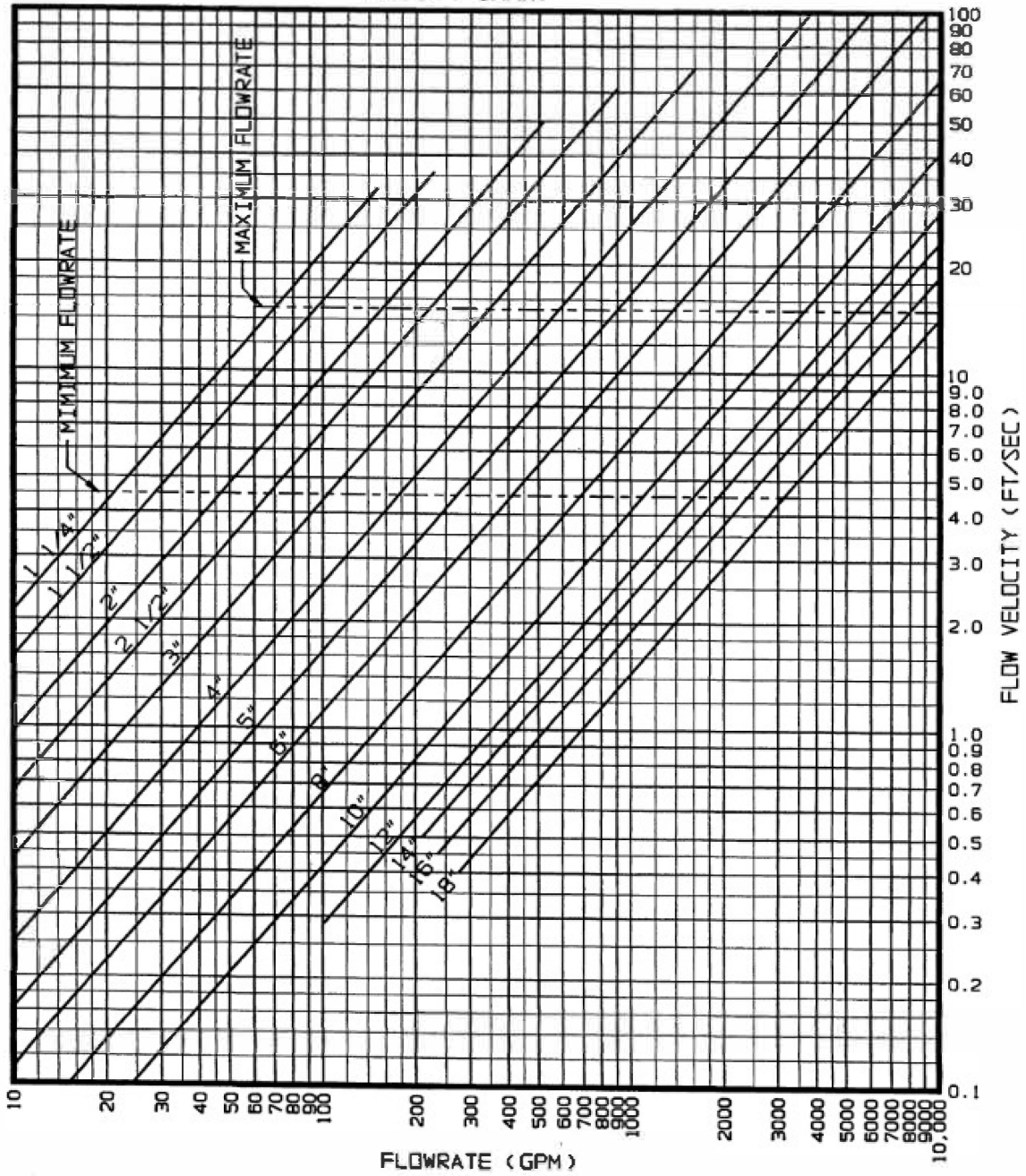

SUBMERSIBLE CHECK VALVE  
FRICTION LOSS CHART

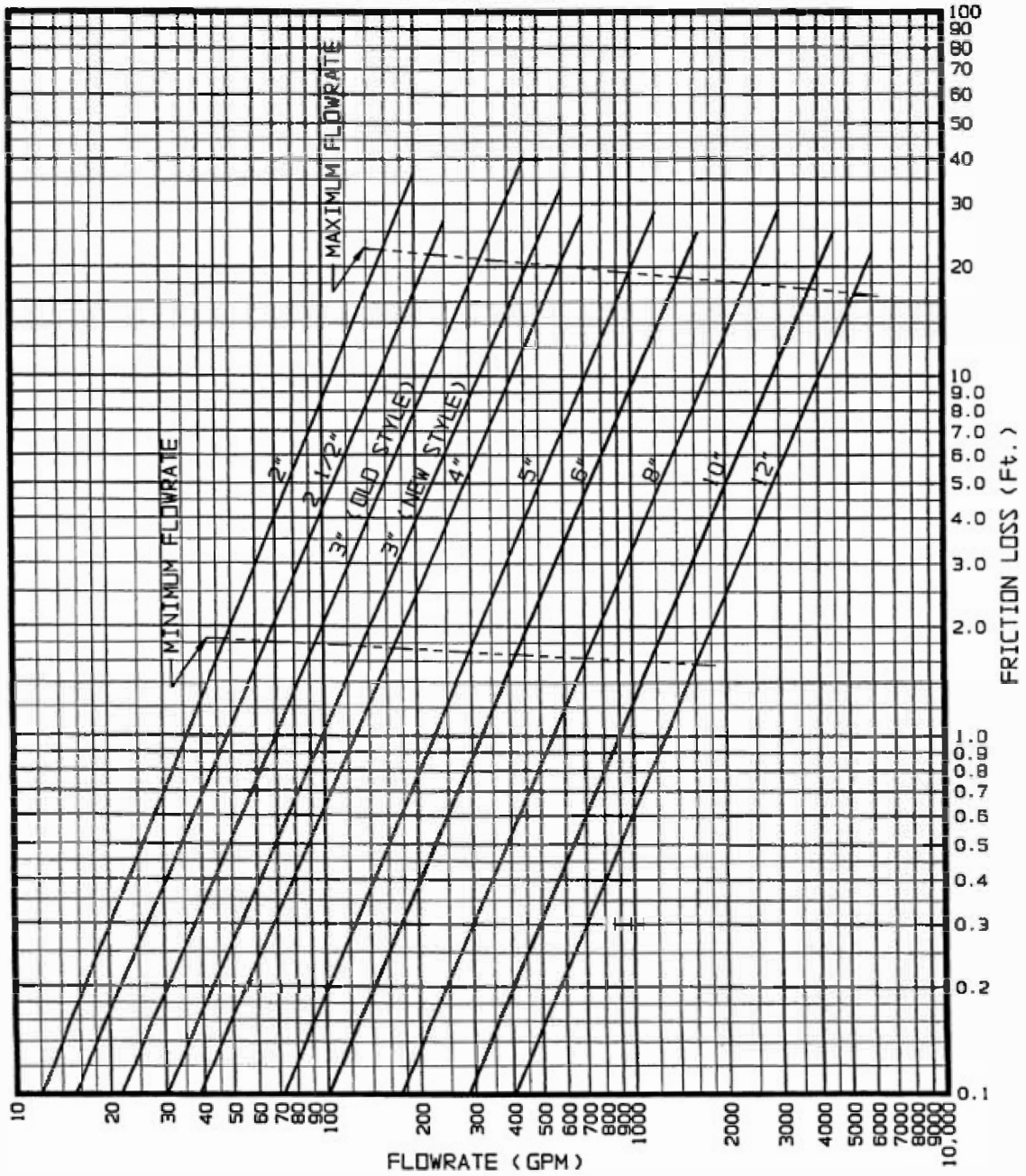

SUBMERSIBLE SURFACE PLATE  
FRICTION LOSS CHART

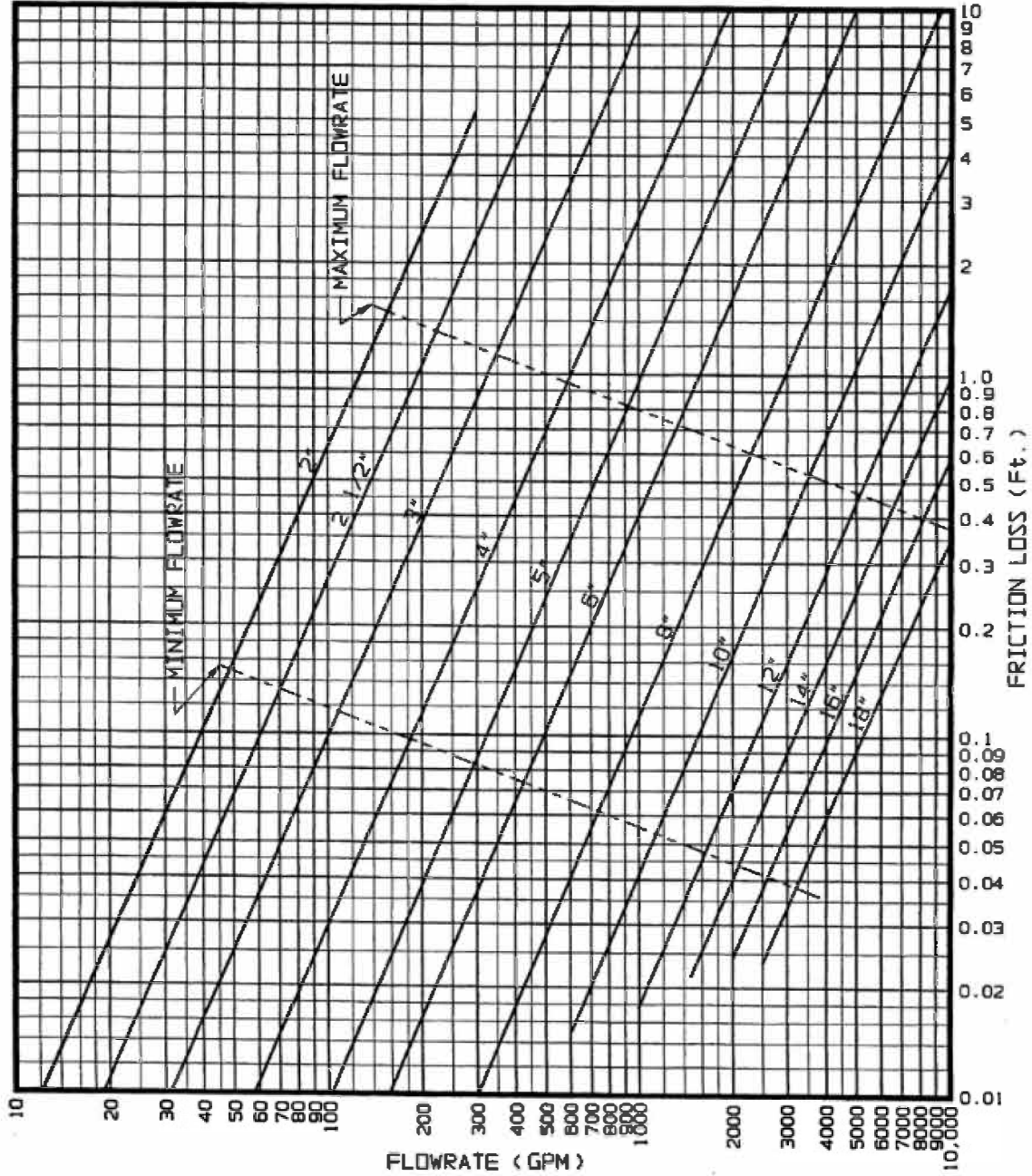

**SUBMERSIBLE PUMP  
WITH THREADED COLUMN PIPE**

---

**DATE** \_\_\_\_\_ **DISTRIBUTOR** \_\_\_\_\_

---

**JOB** \_\_\_\_\_ **GPM** \_\_\_\_\_ **TDH** \_\_\_\_\_

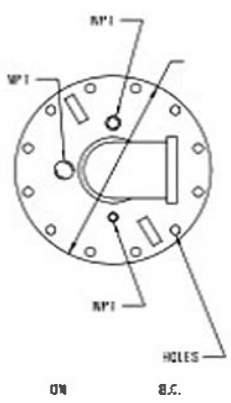
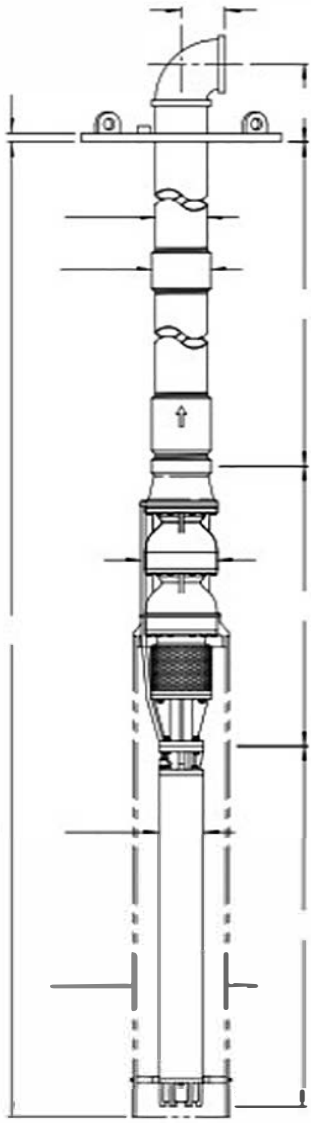

**DISCHARGE HEAD** \_\_\_\_\_  
 \_\_\_\_\_  
**DISCHARGE FLANGE** \_\_\_\_\_  
 \_\_\_\_\_  
**FOUNDATION PLATE** \_\_\_\_\_  
 \_\_\_\_\_  
**COLUMN ASSEMBLY** \_\_\_\_\_  
 \_\_\_\_\_  
**CHECK VALVE** \_\_\_\_\_  
 \_\_\_\_\_  
**CABLE** \_\_\_\_\_  
 \_\_\_\_\_  
**BOWL MODEL #** \_\_\_\_\_  
**IMPELLER DIAMETER** \_\_\_\_\_  
**IMPELLER TYPE** \_\_\_\_\_  
**SPECIAL** \_\_\_\_\_  
 \_\_\_\_\_  
**MOTOR MAKE** \_\_\_\_\_  
**HP** \_\_\_\_\_ **SIZE** \_\_\_\_\_  
**R.P.M.** \_\_\_\_\_  
**PHASE** \_\_\_\_\_ **HERTZ** \_\_\_\_\_  
**VOLTAGAGE** \_\_\_\_\_  
**OTHER** \_\_\_\_\_  
 \_\_\_\_\_  
**OTHER** \_\_\_\_\_  
 \_\_\_\_\_  
 \_\_\_\_\_  
 \_\_\_\_\_



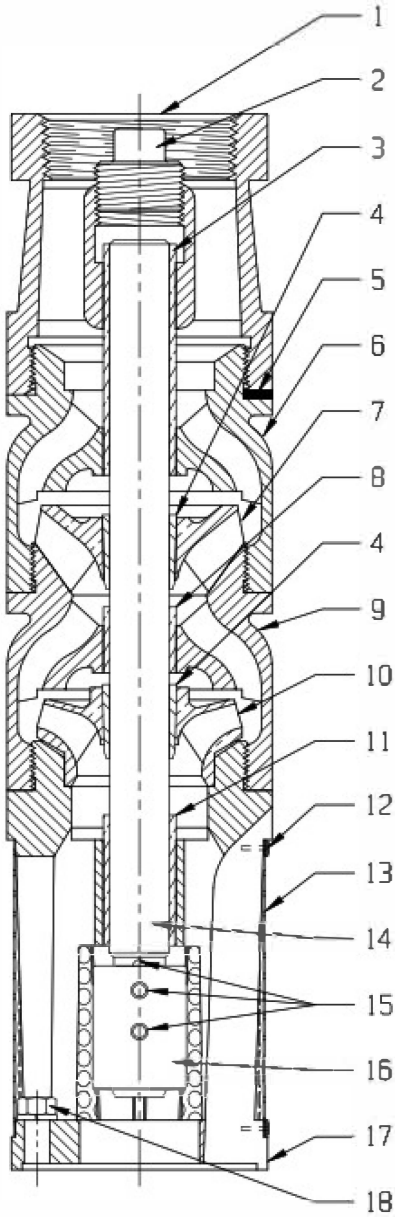

ORDER # \_\_\_\_\_ QUOTE # \_\_\_\_\_

CUSTOMER \_\_\_\_\_

JOB \_\_\_\_\_ DATE \_\_\_\_\_

PUMP END MODEL \_\_\_\_\_ STAGES \_\_\_\_\_

SERIAL # \_\_\_\_\_ TRIM \_\_\_\_\_

BOWL SHAFT SIZE \_\_\_\_\_ COUPLING \_\_\_\_\_

DISCHARGE SIZE \_\_\_\_\_ BOWL DIAMETER \_\_\_\_\_

MOTOR \_\_\_\_\_ SIZE \_\_\_\_\_

RPM \_\_\_\_\_ PHASE \_\_\_\_\_ VOLTAGE \_\_\_\_\_

CYCLE \_\_\_\_\_ OTHER \_\_\_\_\_

ITEM #	DESCRIPTION	MATERIALS	
		STANDARD	OTHER
1	DISCHARGE BOWL	CAST IRON CLASS 30	
2	PIPE PLUG	COMMERCIAL	
3	DISCHARGE BUSHING	BRONZE ASTM B-606-88836	
4	IMPELLER COLLET	STEEL C1 018	
5	BOWL PIN (When Req'd)	BRASS	
6	TOP BOWL	CAST IRON CLASS 30	
7	IMPELLER - OPEN	BRONZE ASTM B-584-88833	
8	INTERMEDIATE BOWL BEARING	BRONZE RUBBER COMBINATION	
9	INTERMEDIATE BOWL	CAST IRON CLASS 30	
10	IMPELLER - ENCLOSED	BRONZE ASTM B-584-88833	
11	MOTOR BRACKET BUSHING	BRONZE ASTM B-505-88835	
12	SCREEN RIVETS	STAINLESS	
13	SCREEN	STAINLESS	
14	BOWL SHAFT	STAINLESS TYPE 416	
15	MOTOR COUPLING KEY & SETSCREWS	STAINLESS	
16	MOTOR COUPLING	STAINLESS	
17	MOTOR BRACKET	CAST IRON CLASS 30	
18	MOTOR NUTS & LOCKWASHERS	STAINLESS	

REFERENCE CURVE \_\_\_\_\_

REFERENCE DRAWINGS \_\_\_\_\_

ORDER # \_\_\_\_\_ QUOTE # \_\_\_\_\_

CUSTOMER \_\_\_\_\_

JOB \_\_\_\_\_ DATE \_\_\_\_\_

PUMP END MODEL \_\_\_\_\_ STAGES \_\_\_\_\_

SERIAL # \_\_\_\_\_ TRIM \_\_\_\_\_

BOWL SHAFT SIZE \_\_\_\_\_ COUPLING \_\_\_\_\_

DISCHARGE SIZE \_\_\_\_\_ BOWL DIAMETER \_\_\_\_\_

MOTOR \_\_\_\_\_ SIZE \_\_\_\_\_

RPM \_\_\_\_\_ PHASE \_\_\_\_\_ VOLTAGE \_\_\_\_\_

CYCLE \_\_\_\_\_ OTHER \_\_\_\_\_

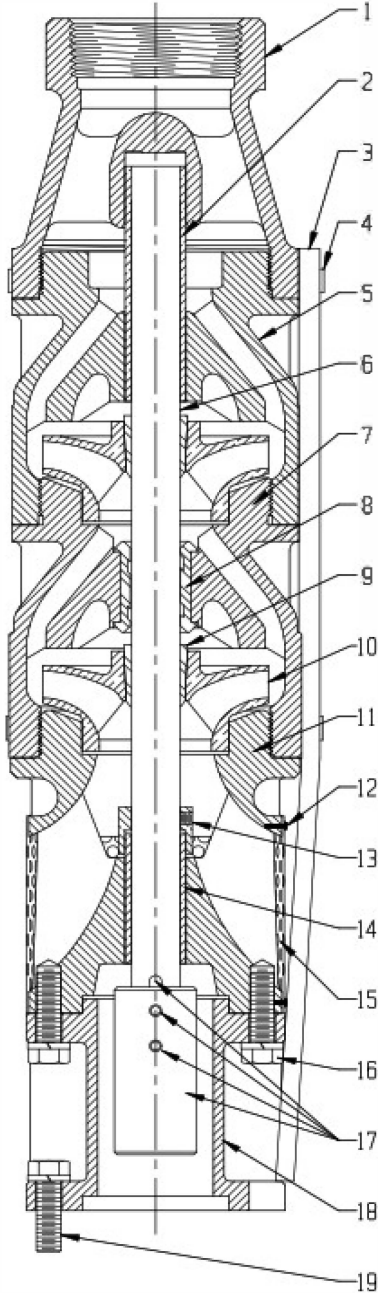

ITEM #	DESCRIPTION	MATERIALS	
		STANDARD	OTHER
1	DISCHARGE BOWL	CAST IRON CLASS 30	
2	DISCHARGE BUSHING	BRONZE ASTM B-505-89835	
3	CABLE GUARD	STAINLESS	
4	CABLE GUARD BAND	STAINLESS	
5	TOP BOWL	CAST IRON CLASS 30	
6	BOWL SHAFT	STAINLESS TYPE 418	
7	INTERMEDIATE BOWL	CAST IRON CLASS 30	
8	INTERMEDIATE BOWL BEARING	BRONZE RUBBER COMBINATION	
9	IMPELLER COLLET	STEEL C1 D18	
10	IMPELLER ENCLOSED OPEN	BRONZE ASTM B-584-89833	
11	MOTOR BRACKET	CAST IRON CLASS 30	
12	SCREEN RIVETS	STAINLESS	
13	SAND COLLAR	BRONZE ASTM B-505-89835	
14	MOTOR BRACKET BUSHING	BRONZE ASTM B-505-89835	
15	SCREEN	STAINLESS	
16	MOTOR BRACKET CAPSCREWS	STAINLESS	
17	MOTOR COUPLING, KEY & SETSCREWS	STAINLESS	
18	MOTOR ADAPTER	CAST IRON CLASS 30	
19	MOTOR BOLTS & LOCKWASHERS	STAINLESS	

REFERENCE CURVE \_\_\_\_\_

REFERENCE DRAWINGS \_\_\_\_\_

ORDER # \_\_\_\_\_ QUOTE # \_\_\_\_\_

CUSTOMER \_\_\_\_\_

JOB \_\_\_\_\_ DATE \_\_\_\_\_

PUMP END MODEL \_\_\_\_\_ STAGES \_\_\_\_\_

SERIAL # \_\_\_\_\_ TRIM \_\_\_\_\_

BOWLSHAFT SIZE \_\_\_\_\_ COUPLING \_\_\_\_\_

DISCHARGE SIZE \_\_\_\_\_ BOWL DIAMETER \_\_\_\_\_

MOTOR \_\_\_\_\_ SIZE \_\_\_\_\_

RPM \_\_\_\_\_ PHASE \_\_\_\_\_ VOLTAGE \_\_\_\_\_

CYCLE \_\_\_\_\_ OTHER \_\_\_\_\_

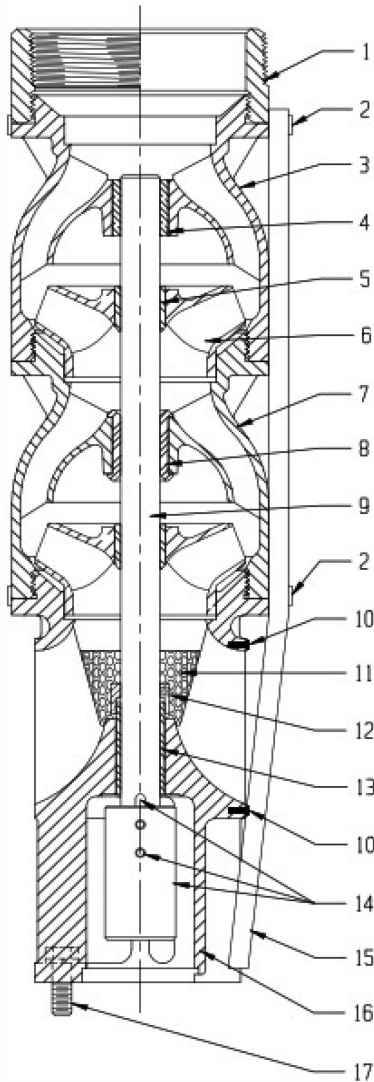

ITEM #	DESCRIPTION	MATERIALS	
		STANDARD	OTHER
1	DISCHARGE ADAPTER	CAST IRON CLASS 30	
2	CABLE GUARD BAND	STAINLESS	
3	TOP BOWL	CAST IRON CLASS 30	
4	TOP BOWL BEARING	BRONZE ASTM B-505-89835	
5	IMPELLER COLLET	STEEL C1018	
6	IMPELLER-ENCLOSED	BRONZE ASTM B-584-89833	
7	INTERMEDIATE BOWL	CAST IRON CLASS 30	
8	INTERMEDIATE BOWL BEARING	BRONZE RUBBER COMBINATION	
9	BOWLSHAFT	STAINLESS TYPE 418	
10	SCREEN RIVETS	STAINLESS	
11	SCREEN	STAINLESS	
12	SAND COLLAR	BRONZE ASTM B-505-89835	
13	MOTOR BRACKET BUSHING	BRONZE ASTM B-505-89835	
14	MOTOR COUPLING, KEY & SETSCREWS	STAINLESS	
15	CABLE GUARD	STAINLESS	
16	MOTOR BRACKET	CAST IRON CLASS 30	
17	MOTOR BOLTS & LOCKWASHERS	STAINLESS	

REFERENCE CURVE \_\_\_\_\_

REFERENCE DRAWINGS \_\_\_\_\_

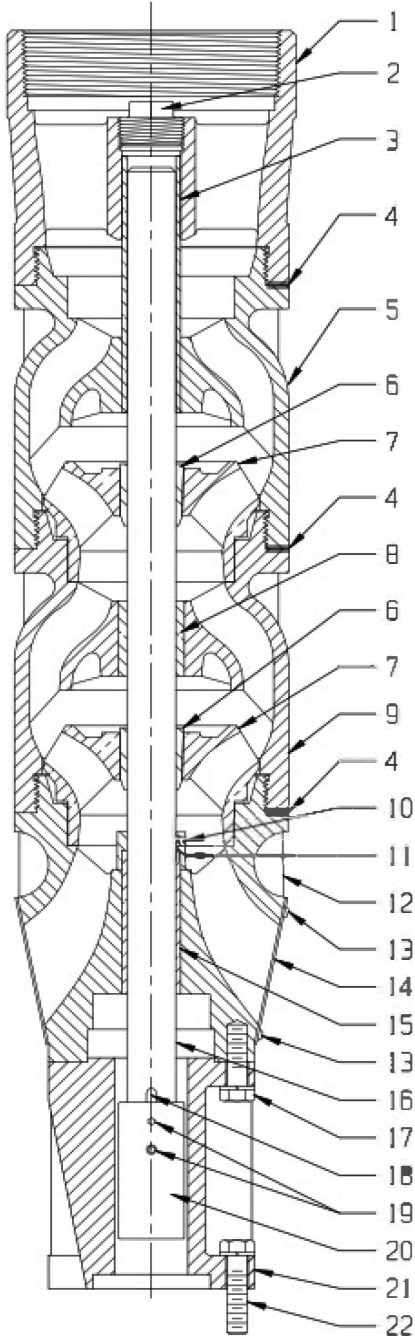

ORDER # \_\_\_\_\_ QUOTE # \_\_\_\_\_

CUSTOMER \_\_\_\_\_

JOB \_\_\_\_\_ DATE \_\_\_\_\_

PUMP END MODEL \_\_\_\_\_ STAGES \_\_\_\_\_

SERIAL # \_\_\_\_\_ TRIM \_\_\_\_\_

BOWL SHAFT SIZE \_\_\_\_\_ COUPLING \_\_\_\_\_

DISCHARGE SIZE \_\_\_\_\_ BOWL DIAMETER \_\_\_\_\_

MOTOR \_\_\_\_\_ SIZE \_\_\_\_\_

RPM \_\_\_\_\_ PHASE \_\_\_\_\_ VOLTAGE \_\_\_\_\_

CYCLE \_\_\_\_\_ OTHER \_\_\_\_\_

ITEM #	DESCRIPTION	MATERIALS	
		STANDARD	OTHER
1	DISCHARGE BOWL	CAST IRON CLASS 30	
2	PIPE PLUG	COMMERCIAL	
3	DISCHARGE BUSHING	BRONZE ASTM B-505-88835	
4	BOWL PIN	BRASS	
5	TOP BOWL	CAST IRON CLASS 30	
6	IMPELLER COLLET	STEEL C1018	
7	IMPELLER-ENCLOSED	BRONZE ASTM B-584-88833	
8	INTERMEDIATE BOWL BEARING	BRONZE RUBBER COMBINATION	
9	INTERMEDIATE BOWL	CAST IRON CLASS 30	
10	SAND COLLAR SETSCREWS	STAINLESS	
11	SAND COLLAR	BRONZE ASTM B-505-88835	
12	MOTOR BRACKET	CAST IRON CLASS 30	
13	SCREEN RIVETS	STAINLESS	
14	SCREEN	STAINLESS	
15	MOTOR BRACKET BUSHING	BRONZE ASTM B-505-88835	
16	BOWL SHAFT	STAINLESS TYPE 416	
17	MOTOR BRACKET CAPSCREWS	STAINLESS	
18	COUPLING KEY	STAINLESS	
19	COUPLING SETSCREWS	STAINLESS	
20	MOTOR COUPLING	STAINLESS	
21	MOTOR ADAPTOR	CAST IRON CLASS 30	
22	MOTOR BOLTS & LOCKWASHERS	STAINLESS	

REFERENCE CURVE \_\_\_\_\_

REFERENCE DRAWINGS \_\_\_\_\_

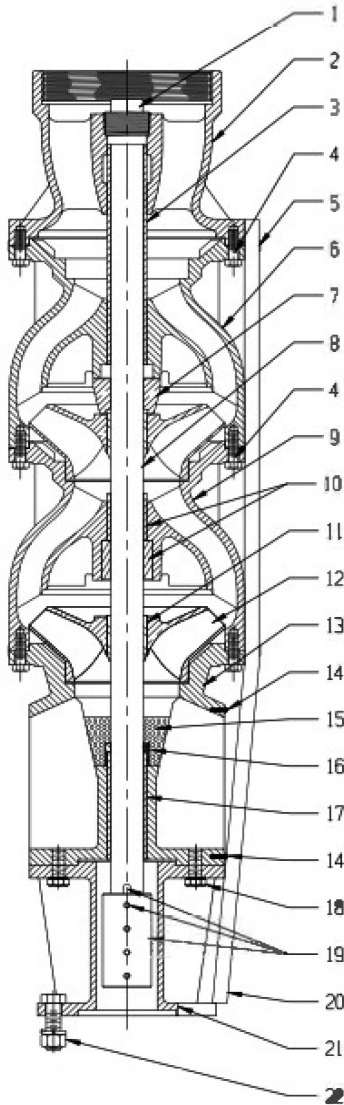

ORDER # \_\_\_\_\_ QUOTE # \_\_\_\_\_

CUSTOMER \_\_\_\_\_

JOB \_\_\_\_\_ DATE \_\_\_\_\_

PUMP END MODEL \_\_\_\_\_ STAGES \_\_\_\_\_

SERIAL # \_\_\_\_\_ TRIM \_\_\_\_\_

BOWLSHAFT SIZE \_\_\_\_\_ COUPLING \_\_\_\_\_

DISCHARGE SIZE \_\_\_\_\_ BOWL DIAMETER \_\_\_\_\_

MOTOR \_\_\_\_\_ SIZE \_\_\_\_\_

RPM \_\_\_\_\_ PHASE \_\_\_\_\_ VOLTAGE \_\_\_\_\_

CYCLE \_\_\_\_\_ OTHER \_\_\_\_\_

ITEM #	DESCRIPTION	MATERIALS	
		STANDARD	OTHER
1	PIPE PLUG	COMMERCIAL	
2	DISCHARGE BOWL	CAST IRON CLASS 30	
3	DISCHARGE BUSHING	BRONZE ASTM B-505-89835	
4	CAPSCREWS	STAINLESS	
5	CABLE GUARD BAND	STAINLESS	
6			
7	UPTHRUST COLLAR	BRONZE ASTM B-505-89835	
8	BOWLSHAFT	STAINLESS TYPE 418	
9	INTERMEDIATE BOWL	CAST IRON CLASS 30	
10	INTERMEDIATE BOWL BEARING	BRONZE RUBBER COMBINATION	
11	IMPELLER COLLET	STEEL C1018	
12	IMPELLER ENCLOSED OPEN	BRONZE ASTM B-504-89833	
13	MOTOR BRACKET	CAST IRON CLASS 30	
14	SCREEN RIVETS	STAINLESS	
15	SCREEN	STAINLESS	
16			
17	SAND COLLAR	BRONZE ASTM B-505-89835	
18	MOTOR BRACKET BUSHING	BRONZE ASTM B-505-89836	
19	MOTOR BRACKET CAPSCREWS	STAINLESS	
20	MOTOR COUPLING, KEY & SET SCREWS	STAINLESS	
21	CABLE GUARD	STAINLESS	
22	MOTOR ADAPTOR	CAST IRON CLASS 30	
	MOTOR BOLTS & LOCKWASHERS	STAINLESS	

REFERENCE CURVE \_\_\_\_\_

REFERENCE DRAWINGS \_\_\_\_\_